

## Company Directive

### STANDARD TECHNIQUE: SD4A/4

#### Design of Western Power Distribution's 11kV and 6.6kV Networks

**Author:** Andy Hood

**Implementation Date:** September 2020

**Approved by**



**Paul Jewell**  
DSO Development Manager

**Date:** 16<sup>th</sup> September 2020

Target Staff Group	Staff involved in the design, installation, operation and maintenance of Western power distribution's 11kV and 6.6kV networks
Impact of Change	Amber – the changes affect the design of Western Power Distribution's 11kV and 6.6kV networks
Planned Assurance Checks	One year after issue the author will check that 1000kVA padmount transformers are being utilised in accordance with this standard technique.

**NOTE:** The current version of this document is stored in the WPD Corporate Information Database. Any other copy in electronic or printed format may be out of date. Copyright © 2020 Western Power Distribution

## **IMPLEMENTATION PLAN**

### **Introduction**

This document specifies the requirements for the design of Western Power Distribution's (WPD's) High Voltage distribution system.

### **Main Changes**

The network performance and security of supply section, 2.1.3, has been updated to incorporate changes to POL:SD4. Changes have also been made to section 2.2.2.14 to allow the use of 1000kVA padmount transformers that exclusively supply electric vehicle charger installations and to clarify the application of ground mounted split phase transformers in parts of South Wales.

### **Impact of Changes**

<b>Target Staff Group</b>	<b>Staff involved in the design, installation, operation and maintenance of Western power distribution's 11kV and 6.6kV networks</b>
<b>Impact of Change</b>	<b>Amber – the changes affect the design of Western Power Distribution's 11kV and 6.6kV networks</b>

### **Implementation Actions**

Managers responsible for staff involved with the design of the HV Network shall ensure that these staff are familiar with, and follow, the requirements of this document.

### **Implementation Timetable**

Document implemented on issue for new and substantially modified networks.

## REVISION HISTORY

<b>Document Revision &amp; Review Table</b>		
<b>Date</b>	<b>Comments</b>	<b>Author</b>
September 2020	<ul style="list-style-type: none"> <li>The network performance and security of supply section, 2.1.3, has been updated to incorporate changes to POL: SD4</li> <li>Section 2.2.2.14 has been changed to allow the use of 1000kVA padmount transformers that exclusively supply electric vehicle charger installations</li> <li>Section 2.2.2.14 g) has been modified to allow ground mounted substations to be configured for split phase in certain parts of South Wales where urban split phase networks have been installed historically</li> </ul>	Andy Hood
December 2018	<ul style="list-style-type: none"> <li>References to ENA EREC G98 and ENA EREC G99 have been included in Sections 2.1.7.1 and 2.1.8.2</li> <li>100kVA single phase has been removed from the list of pole-mounted transformers in Section 2.2.2.15 (b)</li> <li>Section 2.2.2.15 (i) added, to give guidance on the maximum permissible underground cable length beyond a set of fuses / ASLs</li> <li>Note on ferro-resonance changed from Section 2.2.2.15 (i) to 2.2.2.15 (j), to improve document flow</li> <li>2.2.2.15 Table 1 amended to include 50A ASLs</li> </ul>	Andy Hood/ Seth Treasure
May 2018	<ul style="list-style-type: none"> <li>Clause 2.1.8.5 amended - diminished requirements for earthing conductor laid in parallel with HV cables when within the proximity of a Primary Substation</li> </ul>	Graham Brewster

Contents

1.0 INTRODUCTION..... 5

2.0 POLICY..... 5

3.0 NETWORK MODELLING..... 27

APPENDIX A..... 28

APPENDIX B..... 43

APPENDIX C..... 49

APPENDIX D..... 50

APPENDIX E..... 51

APPENDIX F..... 51

APPENDIX G..... 51

APPENDIX H..... 51

## **1.0 INTRODUCTION**

- 1.1 This document provides guidance on the design of Western Power distribution's (WPD's) 11kV and 6.6kV networks.
- 1.2 The standard secondary distribution voltage is 11kV and all new circuits shall be capable of operating at 11kV even if they are initially energised at 6.6kV. Expansion of established 6.6kV systems beyond their existing geographic area is only permitted with the permission of the Policy Manager.
- 1.3 Where references are made to other codes, regulations, standards and WPD directives the latest issue of the document shall be applied, unless otherwise stated.
- 1.4 Where any difficulty is encountered in the application of this document the issue shall be referred to the Technical Policy Manager who will determine if a variation is appropriate.

## **2.0 POLICY**

### **2.1 General**

The following aspects must be considered when designing 11kV and 6.6kV networks:

- Statutory duties and distribution license conditions
- Network performance and security of supply requirements
- Load ratings of plant / equipment
- Short circuit ratings of plant / equipment
- Statutory voltage limits
- Power quality (rapid voltage changes, flicker, harmonics and unbalance)
- Network earthing
- Customer earthing
- Protection
- Access to plant and equipment.
- Risk of damage / vandalism to plant and equipment.
- Risks to personnel and members of the public.

### 2.1.1 Statutory Requirements

The following Regulations are directly related to the design of 11kV and 6.6kV Networks:

- Health and Safety at Work Regulations
- Electricity Safety, Quality and Continuity Regulations (ESQCR)
- Electricity at Work Regulations (EWR)
- Construction Design and Management Regulations (CDM)

### 2.1.2 License Conditions

WPD must satisfy a series of distribution license conditions. The following license conditions are particularly relevant to the design of 11kV and 6.6kV networks:

- Condition 20 - Compliance with Core Industry Codes. License Condition 20 requires compliance with core industry codes including, the Grid Code (GCode), Distribution Code (DCode), Balancing and Settlement Code (BSC), Connection and Use of System Code (CUSC), Distribution System and Use of System Agreement (DCUSA), Master Registration Agreement (MRA) and the Revenue Protection Code etc.
- Condition 24 - Distribution System Planning Standard and Quality of Performance Reporting. License Condition 24 requires DNOs to comply with ENA Engineering Recommendation P2 (Security of Supply) as amended.

### 2.1.3 Network Performance and Security of Supply

2.1.3.1 As a minimum networks shall be designed to comply with section the Demand Security, Generator Security, Network Integrity and System Integrity requirements specified in POL: SD4.

#### 2.1.3.2 Demand Security

11kV and 6.6kV networks shall be designed to meet the requirements of EREC P2 which specifies the minimum requirements / timescales for restoring demand following faults and outages. In addition to we also endeavour to meet Customer Guarantees for restoring supplies defined in POL: CS3.

#### 2.1.3.2.1 A summary of the relevant requirements of ENA ER P2 is given below.

Under first circuit outage conditions, known as “N-1” conditions, the demand must be restored within the following timescales:

- (a) **Group demand up to 1MW:** The Group Demand is connected on completion of the repair / outage, i.e. the group demand may be left unconnected until the fault has been repaired or the maintenance outage has been completed.
- (b) **Group Demand up >1MW to 12MW:** The Group Demand minus 1MW must be restored within 3 hours. The remaining 1MW is connected on completion of the repair or when the maintenance outage has been completed.
- (c) **Group Demand > 12MW up to 60MW:** The Group Demand minus 12MW or 2/3<sup>rd</sup> of the group demand, whichever is lower, must be restored within 15 minutes. The remaining demand must be restored within 3 hours. Within this category maintenance outages must be carried out without disconnecting demand.

In the context of this document:

- Group Demand is the estimated After Diversity Maximum Demand (ADMD) of a group of connections. The P2 requirements do not apply to generation although certain generator types are considered to contribute towards (i.e. reduce) the Group Demand. Further guidance on the contribution of generation is included in ENA ER P2 and in ENA Engineering Technical Report 130.
- A first circuit outage is a shutdown on one item of plant (e.g. transformer, reactor etc.) or one circuit (e.g. cable or overhead line) within a network. The shutdown could be for operational reasons or due to a fault. Busbar shutdowns are excluded from the scope of P2.

#### 2.1.3.3 Generation Security

11kV and 6.6kV networks are not normally designed to allow customer connections to export Active Power under first circuit outage or second circuit outage conditions unless this is specifically requested and agreed with the relevant customer. Where a customer does require an enhanced level of security this shall be agreed and documented within the Connection Agreement. Where such agreements are in place Western Power Distribution’s 11kV and 6.6kV networks shall be designed to meet these requirements.

#### 2.1.3.4 Network Integrity

11kV and 6.6kV networks shall be designed to allow the network to be operated and maintained without breaching equipment ratings or voltage limits, including the step voltage change limits defined in POL: SD4.

#### 2.1.3.5 System Integrity

In order to maintain network stability, the 11kV and 6.6kV network and its associated telecommunications and information technology (IT) infrastructure shall be designed to prevent step changes of load (demand or generation) of more than 300MW unless otherwise agreed with National Grid. In practice this threshold is unlikely to be breached by 11kV the 6.6kV networks themselves, however, the combined impact of multiple load management schemes (e.g. Active Network Management, soft intertrip schemes or demand response) could potentially exceed these limits if there are widespread comminutions or IT infrastructure issues.

#### 2.1.3.6 Practical Security Requirements

The following practical steps shall also be taken to help satisfy the Demand Security and, to some extent, the Generator Security requirements.

2.1.3.6.1 HV switchgear that is critical to the security or reliability of Western Power Distribution's (WPD's) network shall be easily accessible without undue delay on a 24/7 basis. If these requirements are unachievable or unreliable then either:

- Tele-control facilities should all be provided that allow the HV switchgear to be operated remotely, or;
- The switchgear shall be moved to a more suitable location.

In this context sites (including both ground mounted and pole sites) that include circuit breakers, switches, fuse-gear or automatic sectionalising links that are used to protect or sectionalise WPD's HV network are deemed to be critical. In addition, substations that supply multiple customer connections shall also be accessible on a 24/7 basis.



- 2.1.3.6.2 Any normal open point that when closed interconnects between two primary substations and is capable of supporting 25% or more of the maximum demand connected to either primary substation should be provided with tele-control facilities.
- 2.1.3.6.3 Circuits shall include facilities for sectionalising the network at intervals not exceeding 2km where one or more customer is connected within the section. Sectionalising facilities may include:
- ABIs
  - Fusegear and Automatic Sectionalising Links
  - Circuit breakers including pole-mounted reclosers
  - Sectionalising switches and sectionalisers
  - Ring main units
- 2.1.3.6.4 In the interest of reducing Customer Minutes Lost (CML's) and Customer Interruptions (CI's), WPD's network shall be designed so that the number of customers (including the number of individual IDNO customers connection via an Embedded Network) left disconnected following a fault and after the network has been sectionalised using automated and/or tele-controlled switchgear, shall be no higher than 1500. For the purpose of this requirement, only the first circuit outage (N-1 conditions) shall be considered.
- 2.1.3.6.5 A Spreadsheet has been made available for information regarding IDNO Agreed supply capacities and quantity of connected MPANS which is available via the following link or found within the Policy Dissemination page. Alternatively information can be provided by the Connections Policy Teams.

[IDNO Agreed Supply Capacity and MPAN Quantity tool](#)

## 2.1.4 Load Ratings of Plant and Equipment

- 2.1.4.1 Plant, equipment and circuits shall be rated for the expected load (i.e. demand and generation). When designing networks, consideration shall be given to the:
- normal feeding arrangement.
  - abnormal feeding arrangements that are required to satisfy the requirements of ENA ER P2 (e.g. first circuit outage conditions).

- load profile. Load can be considered to be cyclic if the load factor is less 0.7, where the load factor is the average (i.e. mean) demand over a 24 hour period divided ( $\div$ ) by the maximum demand over that period
- variation of the load and ratings over the year
- predicted changes in demand and generation
- protection settings. In some cases protection settings restrict the load rating of an item of plant, equipment or a circuit.

2.1.4.2 Overhead line ratings are specified in ST:SD8A.

2.1.4.3 HV Underground cable ratings are specified in ST:SD8B Part 2

2.1.4.4 HV Underground cable sizes are specified in POL:CA2/1

2.1.4.5 Transformer ratings are specified in the following standard techniques:

- 132kV, 66kV and 33kV transformer ratings are specified in ST:SD8C
- 11kV and 6.6kV transformer ratings are specified in ST:SD8D.

2.1.4.6 The rating of reactors and resistors including liquid earthing resistors and solid resistors are specific to each of equipment. Ratings are normally specified on the equipment nameplate and should also be recorded in CROWN. Ratings of new reactors and resistors are defined in the relevant specifications, for example EE SPEC:9, 11kV Outdoor Single Phase Neutral Earthing Reactors.

2.1.4.7 Switchgear ratings are specific to the particular item of equipment and are normally stated on the switchgear name plate. Ratings should also be recorded in CROWN. When assessing switchgear ratings consideration must also be given to the rating of ancillary equipment such as current transformers (CTs) and protection relays.

Ratings of new switchgear are defined within WPD specifications, for example:

- EE SPEC:2, 12kV Cable Connected Switchgear.
- EE SPEC:3, 33kV and 12kV Indoor Circuit Breakers including associated Protection and Ancillary Electrical Equipment.
- EE SPEC:10, 12kV and 36kV Outdoor Overhead Conductor Connected Switchgear and VT's.
- EE SPEC:13, 12kV and 36 kV Pole Mounted Enclosed Switchgear
- EE SPEC:119, HV & LV CT Metering Panels

2.1.4.8 Voltage regulator ratings are specific to the particular item of equipment and are normally stated on the plant name plate. Ratings should also be recorded in CROWN. When assessing switchgear ratings consideration must also be given to the rating of ancillary equipment such as current transformers (CTs) and relays.

Ratings of new voltage regulators are defined within WPD specifications, for example EE SPEC:45, 11kV Pole Mounted Regulators

## 2.1.5 Short Circuit Ratings

2.1.5.1 The method used to determine the short circuit duty for Switchgear used in WPDs network is specified in ST:SD7F.

## 2.1.6 Voltage Limits

2.1.6.1 The Electricity Safety, Quality and Continuity Regulations specifies voltage limits for HV and LV connections. These limits are listed below:

- 11.660kV to 10.340kV (phase to phase) on the 11kV network
- 6.996kV to 6.204kV on the 6.6kV network
- 216.2V to 253.0V on the LV network

2.1.6.2 11kV and 6.6kV networks shall be designed so that the voltage at 11kV, 6.6kV and LV connection points satisfy the statutory voltage limits under normal and, as far as possible, under expected back feed arrangements. In order to achieve this requirement 11kV and 6.6kV networks shall be designed so that the voltage is maintained between the limits specified in POL: SD4.

2.1.6.3 POL: SD4 allows lower voltage limits to be applied when 11kV and 6.6kV circuits are fed abnormally under maximum demand conditions, however, it is expected that planned outages will be taken during lightly loaded periods during which normal limits are maintained.

2.1.6.4 When assessing network voltages the Planner must take account of the primary substation tap-change control settings, including:

- Target voltage

- Bandwidth (typically +/-1.5%)
- Type of scheme (negative reactance, circulating current etc.)
- Load / line drop compensation (if applicable)

2.1.6.5 In order to facilitate the connection of both generation and demand, tap positions on distribution transformers should not normally be varied (graded) along the length of the circuit. Given this, the tap-positions on WPD distribution transformers that are normally connected to the same circuit should vary by no more than 2.5%.

2.1.6.6 Appendix B describes the process for assessing the voltage on an HV networks.

2.1.6.7 Agreed Supply Capacity and Diversity

(a) The network must have sufficient capacity (thermal and voltage) to enable HV customers to:

- Operate at their Agreed Import Capacity during normal feeding arrangements and during N-1 conditions (as defined in ENA EREC P2) unless the customer specifically requests and agrees to a non-firm connection.
- Operate at their Agreed Export Capacity under normal feeding arrangements only. A Firm connection is not normally considered for generation connections, unless specifically requested, in order to maximise the generation connected to the alternative circuits.

(b) When load flow studies are carried out:

- Diversity is not normally applied to the Agreed Import Capacity of HV Customer connections or to large IDNO Connections (i.e. with HV points of connection or LV points of connection taken from a dedicated WPD transformer).
- Diversity is normally applied to the maximum demand of each WPD distribution substation supplying LV connected customers. The diversity is determined from the measured maximum demand data (i.e. loggers) for the HV feeder adjusted to remove the impact of generation and the transformer ratings.

**Diversity Factor = Feeder Maximum Demand<sup>[1]</sup> / Total Transformer Capacity**

- Diversity is not normally applied to Agreed Export Capacities (i.e. when minimum demand, maximum generation studies are carried out).

*[1] Note, Feeder Maximum Demand data must be adjusted to remove the effect of generation*

**2.1.7 Power Quality**

2.1.7.1 For new and modified connections the voltage distortion (harmonics) voltage disturbances (flicker and other rapid voltage changes) and voltage unbalance shall be assessed in accordance with ST:SD6F. In addition, the rapid voltage changes due to the connection, disconnection and operation of customer equipment shall be limited to:

- 3% for events that are expected to occur more frequently than once every 3 months.
- 6% for events that are expected to occur more than once per year but no more than once every 3 months. The operation of generator interface protection (G59 or G99 protection) would be expected to be within this category.
- 10% for very infrequent events occurring no more frequently than once per year. Generally fault events are deemed to be within this category.

2.1.7.2 The 3%, 6% and 10% rapid voltage change limits must be satisfied when customer transformers are energised, taking account of magnetising inrush current.

For the purposes of this requirement:

- The normal feeding arrangement is assumed.
- In the absence of more specific information, the mag-inrush current is assumed to be 10x the aggregate name plate rating of the transformers being energised.
- Sequences of switching events that are carried out within a short period of time (e.g. half an hour) to energise transformers in a staged manner are considered to be a single event.

2.1.7.3 Sites that can rapidly switch between import and export (e.g. sites providing fast frequency response) shall meet the above rapid voltage change limits when switching between their maximum import capacity and maximum export capacity.

## 2.1.8 Earthing

2.1.8.1 WPD's 11kV and 6.6kV system is designed to be earthed at its origin (i.e. at source primary substations) only. At other locations, whilst equipment metalwork is connected to earth, the HV windings of parallel generators and transformers (with the exception of 5 limb voltage transformers and equivalent) shall not be connected to earth.

2.1.8.2 Earthing systems and earthing arrangements shall be designed in accordance with POL: TP4, ST: TP21D and EE SPEC: 89. Guidance on generator earthing is provided in ENA EREC G59, G83, G98 and G99.

2.1.8.3 Detailed constructional requirements are defined in the OH (overhead line), CA (cable) and SP (substation plant) series of Standard Techniques.

2.1.8.4 Where an installation (e.g. substation or HV pole) is "hot" (i.e. where the rise of earth potential under earth fault conditions is expected to be greater than 430V) the installation and its HV earth electrode shall be positioned at least:

- 9m from Swimming pools (and other areas where people may reasonably be barefoot)
- 9m from ponds/lakes used for commercial fish farming
- 10m from BT telephone exchanges
- 10m from railway installations
- 9m from LV earth electrode, steel frame buildings and buried metalwork

2.1.8.5 Where paper-lead cables (e.g. a PILC cables) were installed within the vicinity of primary substations it helped to reduce the resistance of the Primary substation's earthing system. This is because the armour and screen of PILC cables are effectively in contact with the ground. The same is not true of cables with an insulating serving (XLPE / EPR).

In order to maintain the Primary substation's HV earthing system, whenever 100m or more of HV PILC cable is to be disconnected and the severed section is located wholly or partially within a 400m radius of a primary substation, then bare 70mm<sup>2</sup> copper conductor shall be laid in parallel with any newly installed HV cable and bonded to the cable screen at the end which is electrically closest to the primary substation. The bare copper conductor shall extend to the far end of the new HV cable or for 200m, whichever is the lesser. Where the bare copper conductor enters or exits a substation it shall alternatively be bonded to the substation's HV earthing system. The bare copper conductor shall be laid in the ground (i.e. in contact with the soil) and shall be positioned 150mm away from plastic HV cables due to the risk of high current flows damaging the cable insulation (EE SPEC: 89).

The only exception to this requirement is where the primary substation itself has been identified as "hot". If this is the case there is a risk that running bare copper electrode with the new HV cable could extend the hot zone of the primary. In such cases Primary System Design should be consulted who will determine whether the 70mm<sup>2</sup> earth electrode should be installed or not.

#### 2.1.9 Protection

2.1.9.1 WPD's 11kV and 6.6kV networks shall be designed to meet the requirements of POL: TP4 and satisfy the protection clearance times in POL: TP9. Further guidance on protection requirements is available from Primary System Design.

2.1.9.2 All circuits are protected by phase over-current protection and the majority by earth fault overcurrent protection. Where a circuit normally includes one or more span of overhead line it must be protected by sensitive earth fault protection in addition to the normal overcurrent protection.

### 2.2 **Network Arrangements**

#### 2.2.1 Primary Substations

2.2.1.1 Primary substations must be designed and configured to satisfy the requirements of ENA P2. In order to meet these requirements the majority of primary substations require two or more primary transformers that are separately protected. Single transformer primary substations may be used where the demand can be restored via the High Voltage network within appropriate timescales following a fault on one of the transformers or on the transformer circuit. Primary transformers located at the same substation should be operated in parallel where fault levels and power quality characteristics permit.

- 2.2.1.2 Primary substations located at different sites shall not be designed to be normally operated in parallel with each other through the 11kV or 6.6kV network. Short term parallels may be made when re-configuring 11kV or 6.6kV networks but the duration shall be kept to minimum.
- 2.2.1.3 11kV and 6.6.kV circuit breakers and protection systems shall be installed inside an appropriate weather proof building.
- 2.2.1.4 Each primary transformer shall have a dedicated 11kV or 6.6kV transformer circuit breaker.
- 2.2.1.5 11kV and 6.6kV busbars shall be split into sections (i.e. one section per primary transformer) by installing bus-section or bus-coupler circuit breakers. Each section of busbars shall be separately protected.
- 2.2.1.6 Where significant levels of generation are connected to the network consideration must be given to the performance of the tap-change control schemes, the rating of the tap-changers and also the performance of any directional overcurrent protection associated with the primary transformers. Further guidance shall be sought from Primary System Design where there is a possibility of reverse power flow through the transformers is possible.

## 2.2.2 11kV and 6.6kV Circuits

- 2.2.2.1 Circuits are normally operated radially (i.e. as open rings).
- 2.2.2.2 Cable circuits fed from the same primary substation may be operated in parallel (i.e. in a close ring arrangement) where an enhanced level of security is required. In such cases the source circuit breakers shall either be:
- Connected to the same section of busbar; or
  - Connected to different sections of busbar normally interconnected via closed bus-section or bus-coupler circuit breakers.

Parallel circuits shall be protected by unit protection and/or by directional protection that discriminates between faults on each circuit / section.



- 2.2.2.3 Circuits that include one or more span of overhead line shall be protected by sensitive earth fault (SEF) protection, in addition to the standard phase fault and earth protection applied to all circuits. Circuits that require SEF protection shall not normally be operated in parallel as the use of directional SEF protection is not approved within WPD.
- 2.2.2.4 For the avoidance of doubt circuits that interconnect between different primary substations shall not be designed to operate in parallel (see 2.2.2.2) since such parallel arrangements are difficult and expensive to protect adequately and can give rise to unacceptably long protection clearance times.
- 2.2.2.5 Sufficient interconnection (switched manually or by SCADA) shall be provided between circuits in order to satisfy the requirements of ENA ER P2.
- 2.2.2.6 Each circuit shall be designed so that it is possible to isolate each section by visiting 4 or fewer substations / HV switching locations (operational ends). For the purposes of this requirement, additional LV switching locations that are used to isolate the HV section from LV connected generation are not counted.
- 2.2.2.7 Circuits may be split into sections using ground mounted circuit breakers, pole mounted auto-reclosers and pole mounted automatic sectionalisers to minimise Customer Interruptions (CIs) and Customer Minutes Lost (CMLs). Auto-reclosing shall be applied to circuits, or sections of circuits, that contain a significant length (e.g. 2km) of overhead line or are prone to transient faults / bird strikes.
- 2.2.2.8 Overhead spurs shall as far as possible be protected by 50A expulsion fuses or by upstream circuit breakers or pole-mounted reclosers. Pole mounted automatic sectionalisers or automatic sectionalising links (ASLs) may also be installed to minimise the length of network and number of customers disconnected when a permanent fault occurs.
- 2.2.2.9 Every pole-mounted transformer shall be positioned downstream of a set of fuses or ASLs positioned in accordance with 2.2.2.8. Every ground mounted and pad-mounted transformer shall be protected by a dedicated oil fuse switch, circuit breaker or by sets of fuses positioned locally to the transformer.
- 2.2.2.10 Automatic sectionalisers and ASLs open within the dead time of an upstream auto-recloser. In order for automatic sectionalisers and ASLs to function correctly the upstream automatic recloser must be rated and set for multi-shot auto-reclosing (i.e. so that it recloses at least twice when a permanent fault occurs).

- 2.2.2.11 Consideration shall be given to the application of SCADA automation schemes and equipment that automatically sectionalise the network when permanent faults occur. These automatic sectionalising schemes are known as SQC schemes. Improvements to network reliability shall be considered in accordance with ST:AM5C and POL:FI 06/04/01.
- 2.2.2.12 Communication requirements for generation connections are specified in ST:SD1G.
- 2.2.2.13 New and replacement overhead lines shall be constructed with three phases even if all the associated customer connections are to be derived from single phase or split phase transformers. The only exception is where a new or replacement section of line is connected downstream of an existing two wire overhead line. In this case it is acceptable to install two conductors initially as long as the new line, including the cross-arms and poles are designed for the future installation of a third phase. When connecting new underground cables to overhead lines that are two wire / single phase, the unused conductor within the cable shall be bonded to earth (this will provide the lowest unbalance capacitance).
- 2.2.2.14 Ground mounted substations shall normally be connected using a ring – tee arrangement. The detailed requirements are listed below:
- (a) The maximum name plate rating for WPD ground mounted transformers is 1000kVA.
  - (b) On each circuit the first ground mounted substation (i.e. connected closest to the primary substation) shall be “ringed” into the network using a ring main unit (RMU) or equivalent. This allows work to be carried out on the primary substation circuit breakers and protection schemes with minimal disruption to customers.
  - (c) With the exception of 1000kVA padmount transformers, WPD and IDNO substations rated at 800kVA or above shall be “ringed” into the HV network (e.g. using a RMU or equivalent). The same principle shall be applied to HV Customer connections with an agreed supply capacity of 800kVA and above, unless the Customer specifically requests a lower level of security.\*
  - (d) With the exception of 1000kVA padmount transformers, All WPD and IDNO substations within 200m of the passing main shall have a ‘ringed’ connection.

The same principle shall be applied to HV Customer connections unless the Customer specifically requests a lower level of security.\*

- (e) WPD and IDNO ground mounted substations shall be alternatively “ringed” and “teed” into the network except where a ringed connection is mandatory under b), c) and d) above. 11kV and 6.6kV connections to Customer installations shall, by default, follow the same ring - tee principle unless the Customer specifically requests a different level of security.\*

*\* Note, the wider network (i.e. the Group Demand) must satisfy the security requirements defined in ENA ER P2 (see 2.1.3.2). In some cases this will preclude the use of a teed HV customer arrangement.*

- (f) 1000kVA padmount transformers may only be used to feed dedicated electric vehicle charge point installations. Other padmount transformer ratings (i.e. 200kVA to 50kVA) may only be used where the installation of a pole-mounted transformer is prevented by planning / consent restrictions (i.e. areas of outstanding natural beauty etc.). 200kVA to 50kVA padmount transformers shall not be used instead of conventional ground mounted transformers. Where a 1000kVA padmount transformer is teed into an 11kV network all the adjacent substations must each be ringed into the network, i.e. no other teed transformers including pole-mounted and pad-mounted transformers are allowed in that section.
- (g) New 11kV and 6.6kV ground mounted and padmount transformers that will be owned or adopted by Western Power Distribution shall satisfy the requirements of EE SPEC:5 and shall be selected from the following list:

Ground Mounted Transformers:

- 1000kVA 3 phase
- 800kVA 3 phase
- 500kVA 3 phase

Padmount Transformers:

- 1000kVA 3 phase
- 200kVA 3 phase
- 100kVA 3 phase
- 50kVA 3 phase
- 100kVA split phase
- 50kVA split phase
- 50kVA single phase

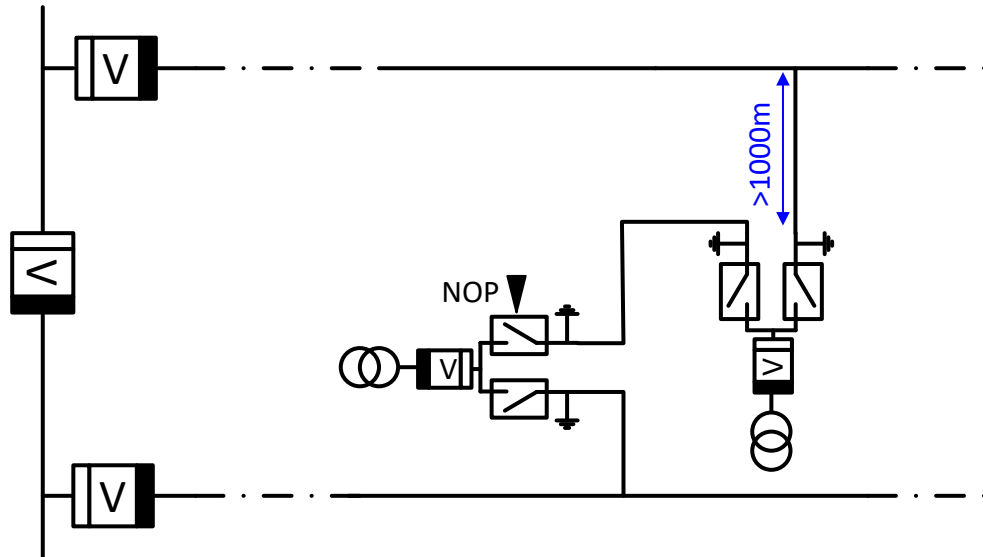
In parts of South Wales urban split phase networks have been historically been provided. In these locations conventional 3 phase ground mounted transformers have, in some cases, been configured for split phase. These networks should be replaced by 3 phase networks where the opportunity arises. In these specific locations existing ground mounted split phase transformers may be replaced like for like or replaced by larger split phase transformers where it is not practical to upgrade the 11kV circuits to three phase.

- (h) Free standing Pole mounted transformers (i.e. connected by 11kV underground cable) may be used / installed as long as consents / planning issues are satisfied and the risk of inadvertent contact with live conductors is negligible. The following sites are deemed to be unsuitable for free standing pole mounted transformers:
- Construction sites
  - Play grounds
  - Sites utilising cranes or forklifts
- (i) LV linking facilities shall be provided where this can be achieved at a reasonable cost (i.e. where there are other suitable cables/lines installed in close proximity to the substation's LV circuits).

- (j) WPD owned LV cabinets shall include suitably rated generator connectors, as specified in EE SPEC16, to facilitate the connection of mobile generators.
- (k) When designing the connection to a new distribution substation consideration shall be given to the distance between the substation site and the existing 11kV or 6.6kV circuit. If the distance is substantial a “ringed” connection would:
- be expensive (due to the length of cable and trenching)
  - increase the circuit impedance of the main circuit which, in turn, will increase the voltage drop / rise beyond the new substation.
  - reduce the prospective short circuit level along the circuit which reduces the ability of protection to detect faults. This may give rise to longer protection operating times and could also have adverse impact on power quality.
  - increase system losses.

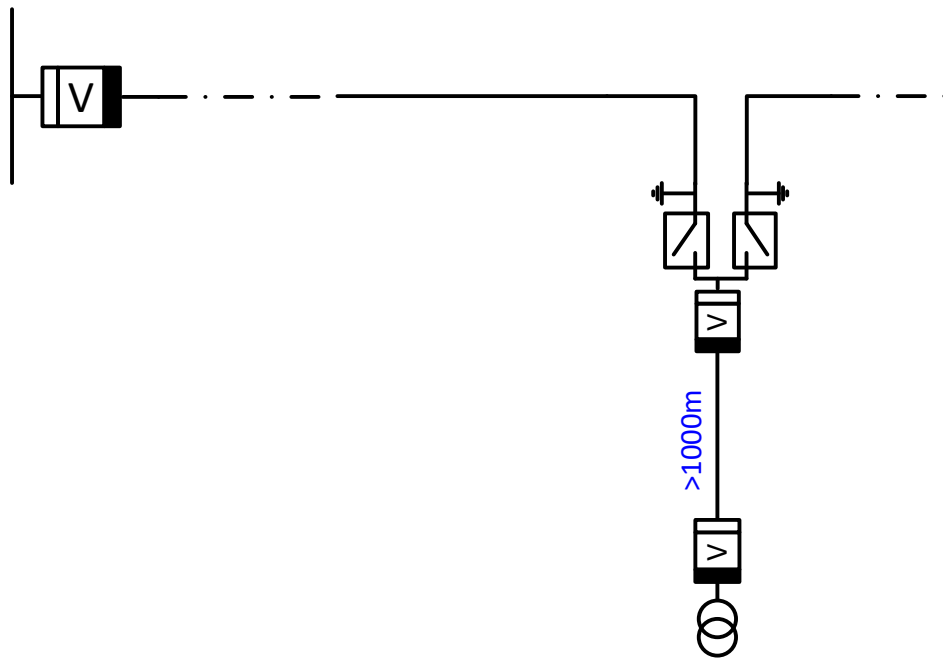
Given the above points, where the distance between the new substation and existing cable is 1000m or more and a ringed connection is required it is recommended that the RMU is interconnected with an alternative circuit (via a normal open point) rather than ringed into the same circuit, as shown in Figure 1. Where the site is remote from an additional circuit the arrangement shown in Figure 2 could be used instead.

When interconnecting between two circuits there shall be at least two Ring Main Units between each circuit. This will allow the RMUs to be maintained or replaced without shutting down both circuits.



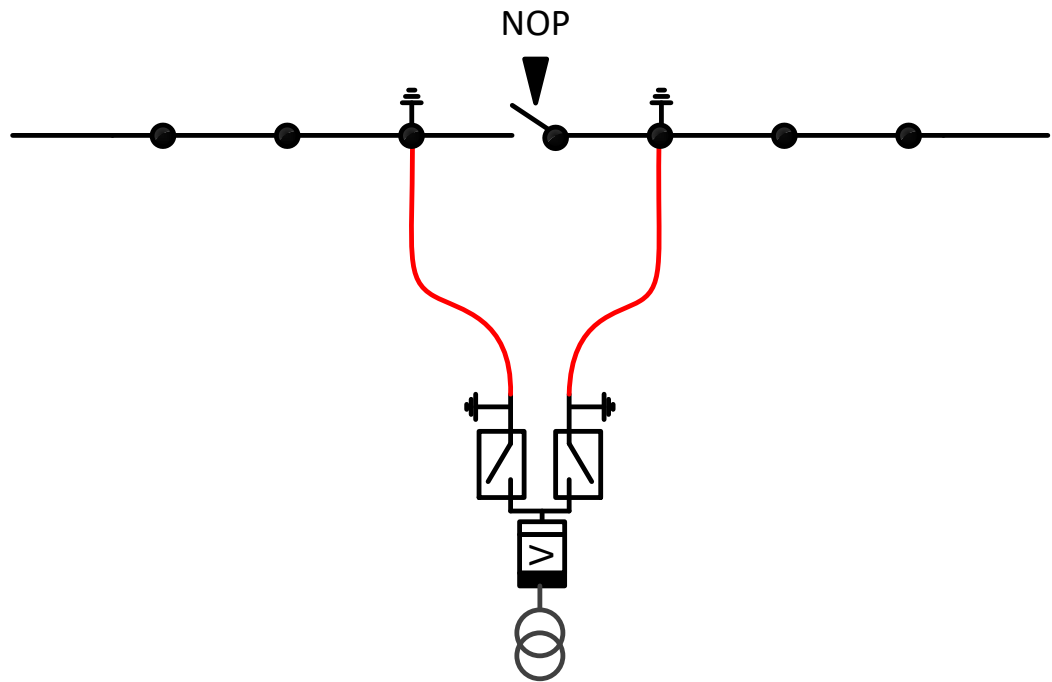
*Note: Circuits must be interconnected via two switching sites (i.e. 2 RMUs) so that the RMUs can be maintained without shutting down both circuits.*

**Figure 1 Arrangement for interconnecting between two HV circuits (e.g. substation > 1000m from main circuit)**



**Figure 2 Alternative to Figure 1 (where substation > 1000m from main circuit).**

- (l) When ringing in a substation the cable or line used to connect the substation shall not reduce the thermal rating of the existing circuit. For example, if an HV circuit comprises of 300mm<sup>2</sup> Al EPR the cable used to ring in a new substation shall have a rating that is equivalent to, or greater than that of the 300mm<sup>2</sup> Al EPR cable.
  
- (m) HV metered connections, including those made to IDNO HV metered connections where the IDNO's customer is metered at HV, shall be protected by a relay (i.e. a self-powered overcurrent and earth fault relay) rather than by Time Limit Fuses (TLFs).

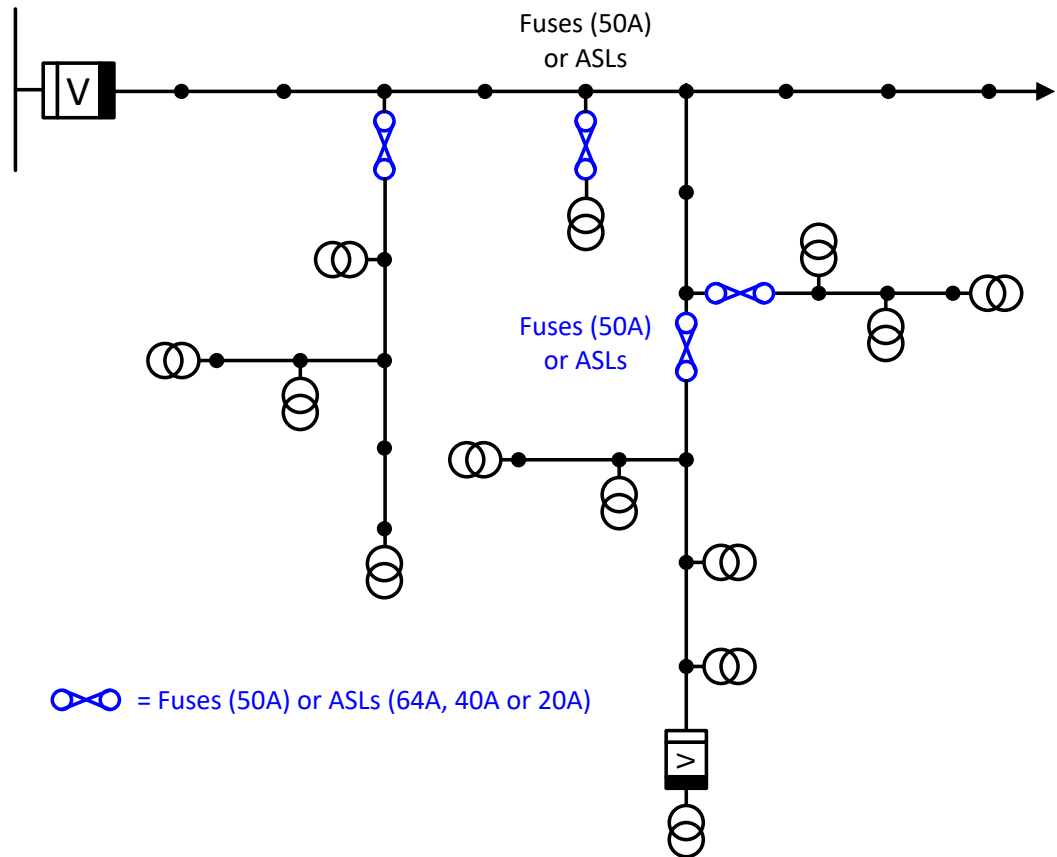


**Figure 3 Connecting a Ground Mounted substation into an Overhead Line**

- (n) When 'Ringing' in a new ground mounted substation into an Overhead Line where the existing overhead conductors can remain in situ. A Normal Open point will be positioned between two individual pole terminations.

2.2.2.15 Pole mounted transformers shall be "teed" into 11kV or 6.6kV circuits. The detailed requirements are listed below:

- (a) The maximum name plate rating for pole mounted transformers is 315kVA.
- (b) New pole-mounted transformers that will be owned or adopted by Western Power Distribution shall satisfy the requirements of EE SPEC:5 and shall be selected from the following list:
- 315kVA 3 phase
  - 200kVA 3 phase
  - 100kVA 3 phase
  - 100kVA split phase
  - 50kVA 3 phase
  - 50kVA single/split phase
  - 25kVA single phase
- (c) Pole-mounted transformers shall be connected downstream of either 50A expulsion fuses, ASLs or a pole mounted sectionaliser. Groups of transformers (i.e. connected on spurs) shall be controlled by a single set of expulsion fuses or ASLs. These arrangements are known as “Group Fused” or “Group Sectionalised”, as appropriate. A typical arrangement is shown in Figure 3.



**Figure 4 Group Fusing / Sectionalising**



- (d) Where more than one pole mounted transformer is installed downstream of a set of fuses or ASLs, additional solid links may be installed to provide additional isolation facilities.
- (e) The maximum aggregate transformer capacity that may be connected downstream of a set of fuses / ASLs is given in Table 1.
- (f) Up to two sets of ASLs may be installed in series. Where this is the case the current ratings and pulse settings shall be graded (i.e. the upstream set of ASLs shall have a larger current rating and a larger pulse setting than the downstream ASLs).
- (g) Overhead expulsion fuses shall not normally be installed in series. The only exception is where a ground mounted transformer that does not have its own oil fuse switch or equivalent circuit breaker, is protected by a set of overhead expulsion fuses with a low current rating (see ST:TP4B for further information on transformer protection). In this situation, 50A expulsion fuses (used to protect the spur) may be connected in series with the expulsion fuses that protect the ground mounted transformer.
- (h) Ground mounted transformers connected to overhead spurs may be installed downstream of overhead expulsion fuses and ASLs where the fuses / ASLs are adequately rated.
- (i) The maximum length of underground cable that may be installed beyond a set of fuses / ASLs shall be no greater than 650m, due to the capability for breaking cable charging current (see ST:OS2D for further information on the operation of pole mounted equipment).
- (j) Due to the risk of ferro-resonance, a ganged switch must be installed for making and breaking of the circuit where long lengths of underground cable are fed via overhead line. Circuits at risk from ferro-resonance where both of the following conditions are satisfied:
- The aggregate transformer capacity is  $\leq 100\text{kVA}$ , and;
  - $\geq 500\text{m}$  of PILC or CAS cable, or  $\geq 1000\text{m}$  of EPR or XLPE cable is installed beyond an overhead line.

Fuse / ASL Rating	Maximum Total Transformer Capacity (A per phase)
<b>11kV Network</b>	
50A O/H Fuse	36.8A *
20A ASLs	12.5A
40A ASLs	25.0A
50A ASLs	31.3A
63A ASLs	36.8A *
<b>6.6kV Network</b>	
50A O/H Fuse	50.0A
20A ASLs	12.5A
40A ASLs	25.0A
50A ASLs	31.3A
63A ASLs	39.4A

**Table 1 Maximum Aggregate Transformer Capacity Connected Downstream of ASLs and Fuses**

*\* The maximum transformer capacity values for 50A fuses and 63A ASLs fitted to the 11kV network are limited by the operational requirements. See Appendix D of ST:OS2D.*

## 2.3 Reinforcement

2.3.1 Where the 11kV or 6.6kV network is reinforced the design and installation shall satisfy the requirements of POL: SD4 and the STs in the SD4 series and clause DIN2.1 (b)(i) of the Distribution Code which states that networks shall be designed as to “permit the development, maintenance, and operation of an efficient, coordinated and economical **System** for the distribution of electricity”. The minimum cost scheme is deemed to be the design that satisfies all of these requirements at the lowest installed cost, assuming WPD carry out all the work, prior to the consideration of cost apportionment.

2.3.2 When the impact of a proposed new load (i.e. additional demand or generation) is assessed and the voltage is found to be outside of network voltage limits (as defined in Table 1 and 2 of POL: SD4) the network should be reinforced in preference to altering the tap positions to non-standard values. This is because manually altering tap positions on large numbers of network substations is extremely time consuming and will disruptive to customers (as changes must be made off load).

2.3.3 If during the assessment of a new or augmented connection the thermal or voltage limits of the existing network are found to be exceeded (i.e. before the additional load is considered) WPD shall fund any required reinforcement to resolve these issues. Any additional reinforcement required to supply the new/augmented connection will be charged/apportioned in accordance with WPD's Statement of Methodology and Charges for Connection to WPD's Distribution System.

### **3.0 NETWORK MODELLING**

3.1 An Alternating Current (AC) load flow design software package must be used for the analysis of High Voltage networks. Examples of some appropriate design software packages are detailed below:

- DINIS
- IPSA
- PSSE
- Digsilent Power Factory

3.2 The analysis of the High Voltage network must detail the below assessments regarding the normal and abnormal running arrangements:

- Voltage
- Thermal (load and short circuit)
- Protection
- Security of supply
- Reverse power flow
- Fault level (for the connection of Generation  $\geq$  50kW and loads with motors  $\geq$  50kW).
- Power Quality

3.3 When analysing High Voltage networks, a record of the design parameters used during the study must be documented. Appendix D the 'High Voltage design – design submission form' shall be completed and retained within the design file / folder. Note this requirement applies to both WPD staff and to ICPs.

## NETWORK MODELLING

### A1 Allocation of Load to Network Models

#### A1.1 General

DINIS software is used for 11kV and 6.6kV load flow studies. It is important that the load is allocated correctly to the model in order to ensure the network is designed correctly.

Two separate conditions are generally considered:

- Maximum demand – zero generation
- Minimum demand – maximum generation

##### A1.1.1 Circuit Data

Spreadsheets are available that extract analogue data derived from transducers, metering and protection equipment and allow this to be studied and manipulated (added, subtracted etc.) before being allocated to the models. The following information is used for load flow studies:

- Measured half hour apparent power data (i.e. MVA or kVA). This information is often derived from half hour voltage and current loggers which are multiplied together.
- Measured half hour apparent power data (i.e. MVA or kVA) for HV metered customers. This is derived from half hourly metering data
- Measured half hourly apparent power data (MVA or kVA) for generator connections
- Agreed supply capacities for all HV metered demand connections.
- Agreed export capacities for all export connections greater than 50kVA.

In the absence of other information, demand should be assumed to operate at a 0.95 lagging power factor, and generation at unity power factor.

## A1.2 Maximum Demand – Zero Generation Studies

Load data for maximum demand / minimum generation studies is allocated in accordance with the process given in Figure A1 and described in the following section.

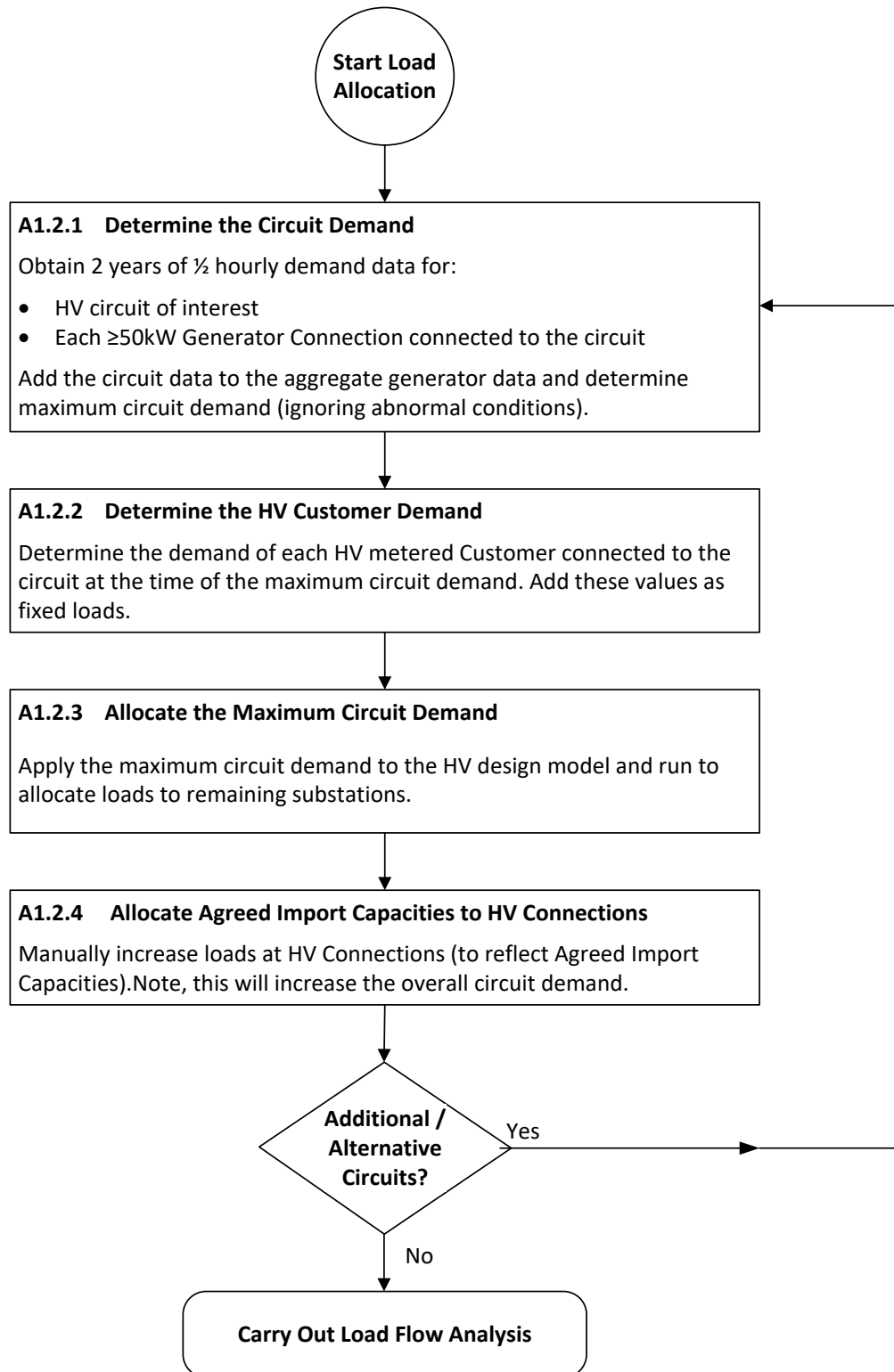
### A1.2.1 Calculation of the Circuit Demand (Apparent Power) Excluding Generation

For each half hour period the true circuit demand excluding the impact of the generation is calculated. It is recommended that previous 2 year period is considered.

This is determined by taking the apparent power measured at the source circuit breaker (at the source primary substation) and adding this to the exported apparent power produced by each  $\geq 50\text{kW}$  generator connected to the circuit. Note, smaller generators are accounted for as they reduce the minimum demand on the circuit.

This can be carried out automatically using the standard logger spreadsheets.

Once this has been completed the half hour with the highest demand is then found, and its value, time and date recorded. Data associated with abnormal running arrangement should be discarded, where this can be identified.



**Figure A1 Allocation of Load Data; Maximum Demand – Zero Generation**

Example: In the circuit shown in Figure A2 the apparent power measured at the source circuit breaker (over one half hour period) is 2.5MVA. During this period the generation connected to the circuit is exporting a total of 1.5MVA.

The total demand connected to the circuit during this period is therefore  $2.5\text{MVA} + 1.5\text{MVA} = 4\text{MVA}$ .

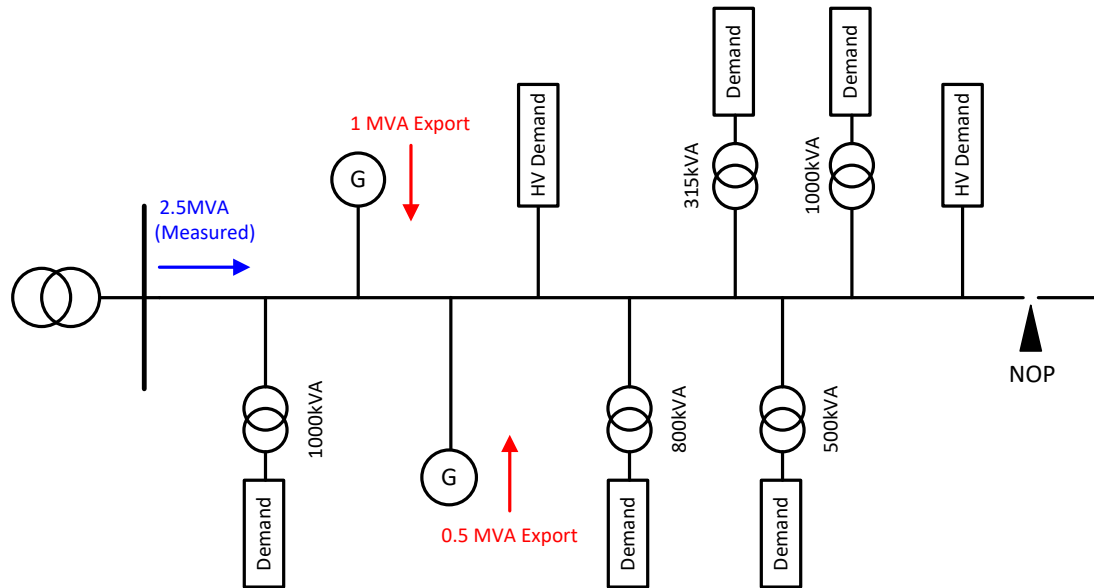
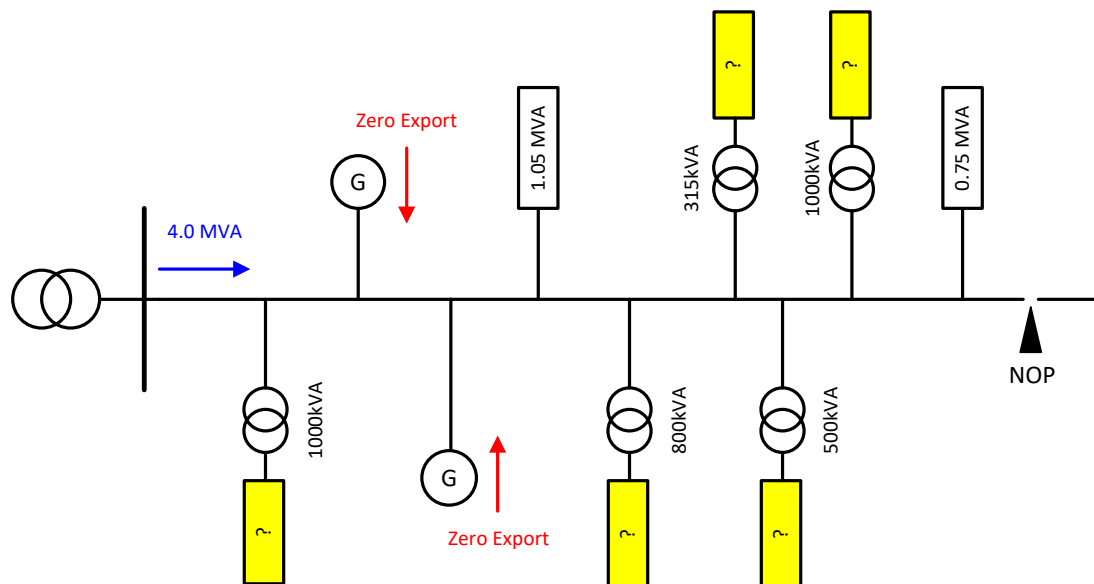


Figure A2 Calculation of Maximum Circuit Demand (with Zero Generation)

### A1.2.2 Determine HV Metered Demands at time of Circuit Maximum Demand

The import demand for each HV metered customer at the time and date of the maximum demand of the circuit is determined and added to the model as fixed demands.

*Example: The maximum demand (excluding generation) of 4MVA occurred at 18:00 on 23rd January 2015 was 4MVA. At this time the two HV metered customers were importing 1.05MVA and 0.75MVA respectively. These values are allocated to the model as shown in Figure A3*



**Figure A3 Allocation of Demand to HV Connections**

### A1.2.3 Apply Maximum Circuit Demands and Allocate Demand to Distribution Transformers

When the maximum circuit demand is applied to DINIS and the load is allocated it applies the known demand first (i.e. to the fixed demands allocated in the HV connections) and then apportions the remaining demand to the other substations in proportion to their transformer capacities.

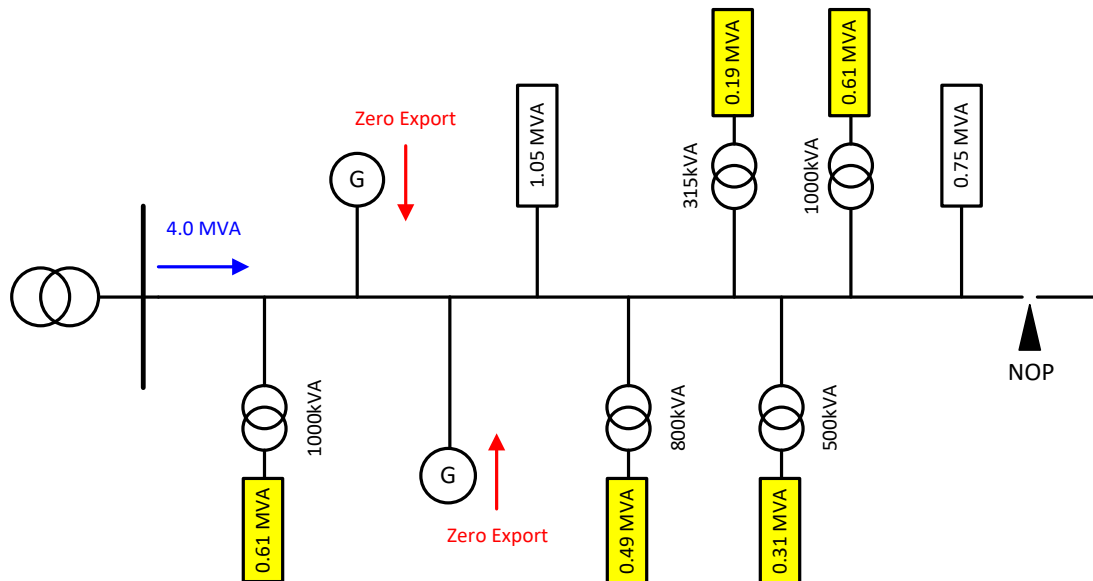
*Example: The remaining demand is  $4\text{MVA} - 1.05\text{MVA} - 0.75\text{MVA} = 2.2\text{MVA}$ .*



If the aggregate capacity of the distribution transformers connected to the circuit is 3.615MVA the demand allocated to each transformer will be  $(2.2/3.615) \times 100 = 60.9\%$  of the transformer's capacity.

In this case the following demands are allocated:

- 1000kVA transformer = 0.61MVA each
- 800kVA transformer = 0.49MVA
- 500kVA transformer = 0.31MVA
- 315kVA transformer = 0.19MVA



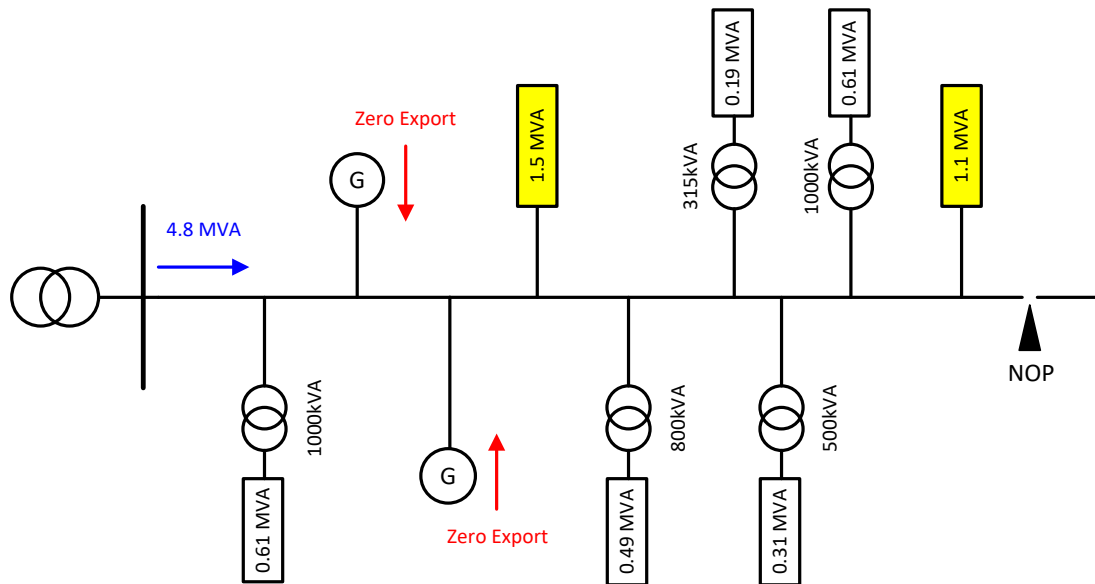
**Figure A3 Allocation of Circuit Demand and remaining load to Network Substation Maximum Demands**

#### A1.2.4 Manual Adjustment of HV Metered Demands

Often the highest half hourly demand determined in A1.2.1 does not coincide with the time of the maximum demand of the individual HV metered customers. If this is the case there is a risk that the future circuit demands could be underestimated. In order to account for this it is normal practice to increase the demand at the HV metered connections to the Agreed Import Capacities for these connections.

Note, HV IDNO connections to large commercial / industrial customers are treated in the same way as HV customer connections (i.e. no diversity is normally assumed) whereas HV IDNO connections that supply domestic customers are treated in the same way as a DNO network substation (i.e. demand is allocated as a proportion of the transformer or supply rating).

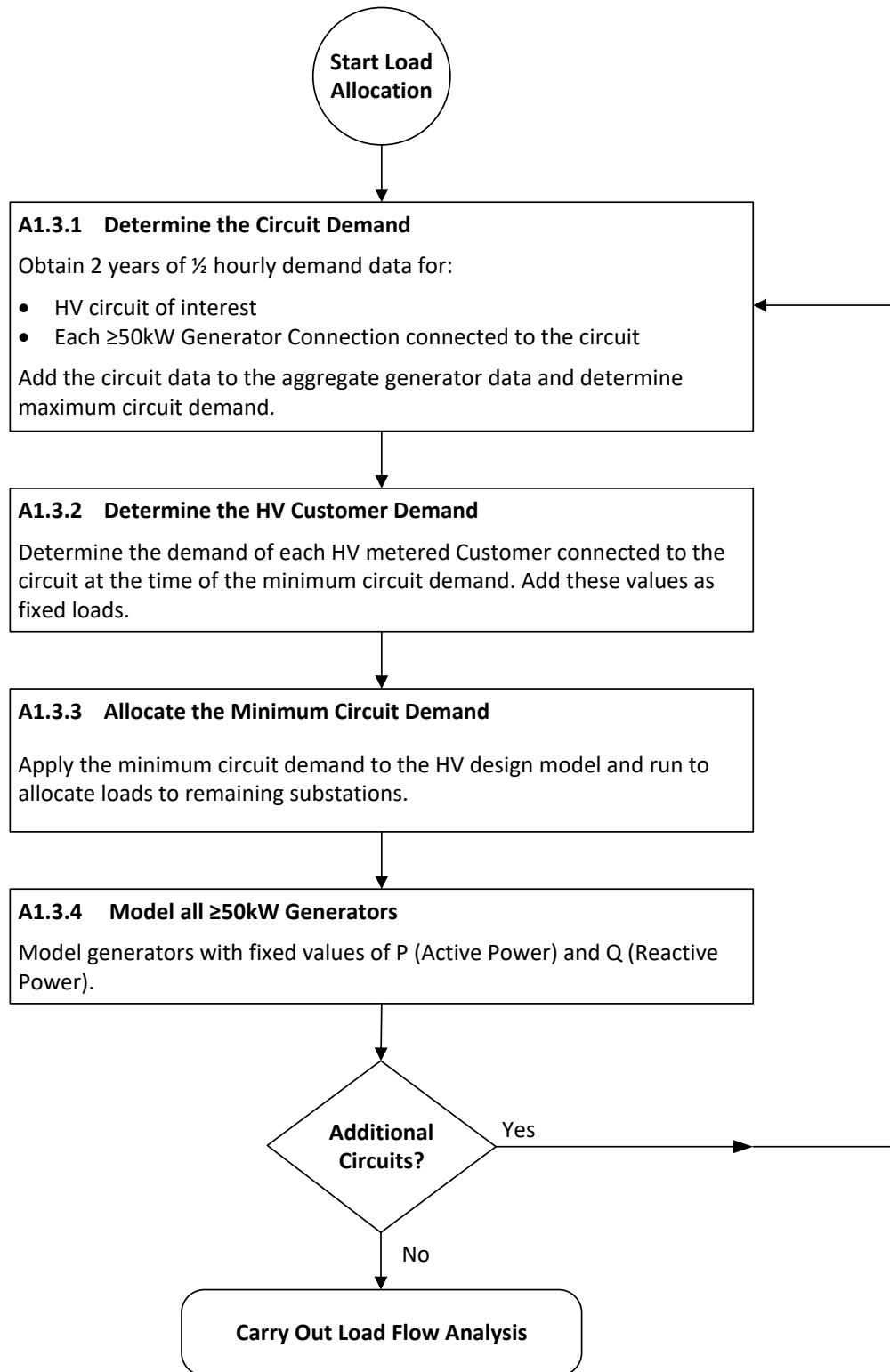
*Example: If the Agreed Import Capacities for the two HV connections are found to be 1.5 MVA and 1.1 MV, respectively the demands allocated to these connections are readjusted accordingly. This increases the circuit maximum demand from 4MVA to 4.8MVA.*



**Figure A4 Allocation of HV Agreed Export Capacities**

**A1.3 Minimum Demand – Maximum Generation Studies**

When carrying out minimum demand / maximum generation studies load is allocated to substations / generation sites and HV customer connections using the process shown in Figure A5 and described in the following section.



**Figure A5 Allocation of Load Data; Minimum Demand – Maximum Generation**

### A1.3.1 Calculation of the Circuit Demand (Apparent Power) Excluding Generation

For each half hour period the true circuit demand is determined by adding the measured circuit demand data to the exported power from  $\geq 50\text{kW}$  generators connected to the circuit (as described in A1.2.1).

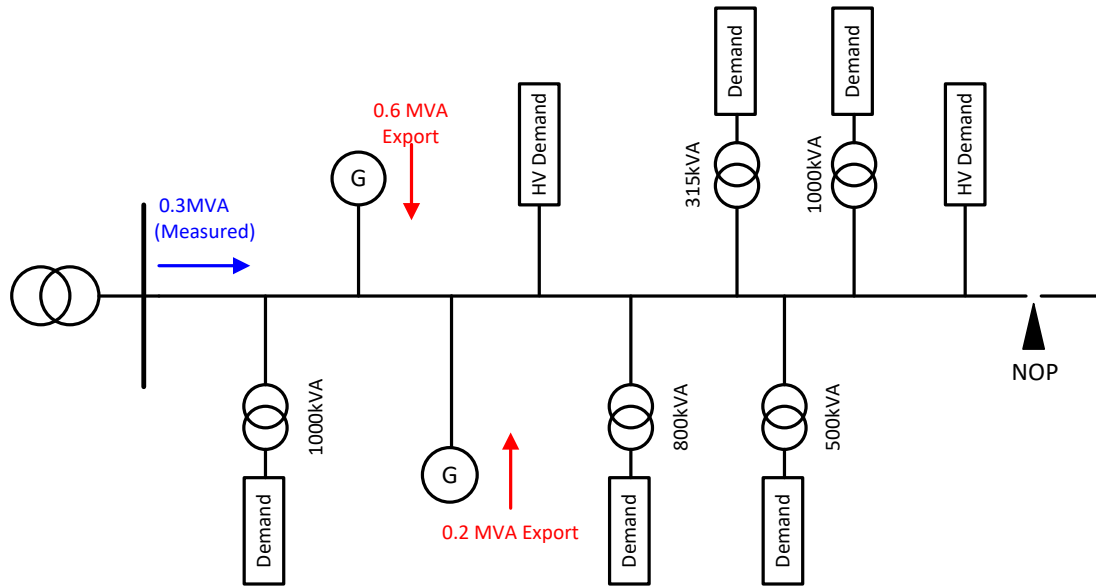
In some cases, the circuit logger data may give a positive (demand) value whereas in reality the power is flowing in the opposite direction (i.e. reverse power flow is occurring at the source circuit breaker). This can usually be identified by looking at the shape of the load profile in the logger spreadsheet. Where reverse power flow occurs circuit demand (excluding generation) is the exported power from the  $\geq 50\text{kW}$  generators minus the measured circuit demand.

Once the minimum circuit demand (excluding generation) has been determined the value and its date and time shall be recorded. Note, where the generation is dominated by photovoltaic installations a summer or spring, daytime value should be selected.

*Example: The measured demand at the source circuit breaker for a particular half hour period is 0.3MVA. At this time the exported power from the two generators connected to the circuit was a total of 0.8MVA.*

*The total demand connected to the network during this period was therefore  $0.3\text{MVA} + 0.8\text{MVA} = 1.1\text{MVA}$ .*

*If however, the measured demand (0.3MVA) at the source circuit breaker was actually flowing in the opposite direction the total demand on the network would have been  $0.8\text{MVA} - 0.3\text{MVA} = 0.5\text{MVA}$ .*

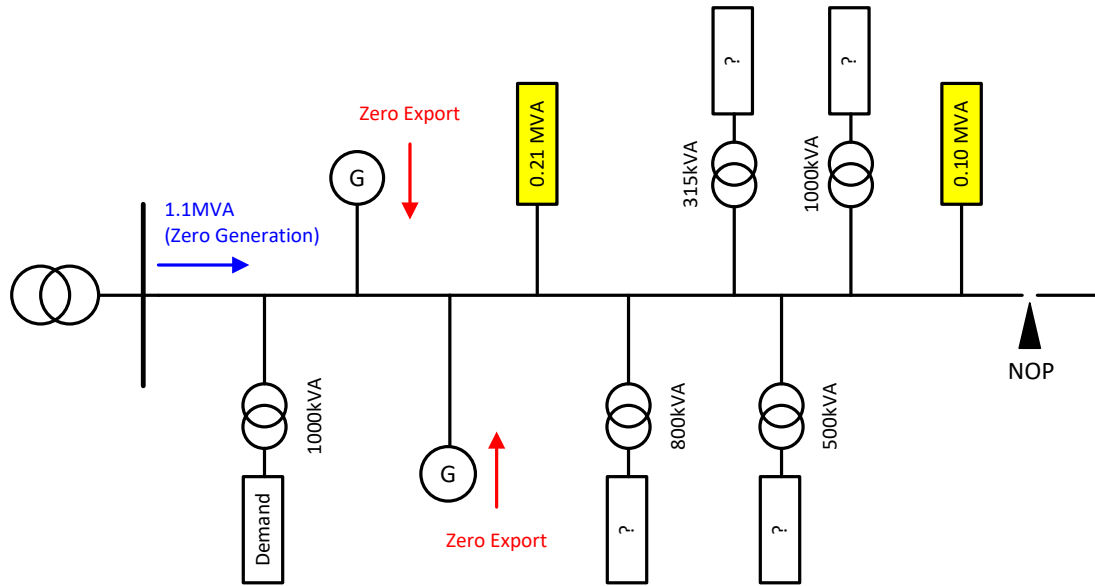


**Figure A6 Calculation of Minimum Circuit Demand (with Zero Generation)**

**A1.3.2 Determine HV Metered Demands at Minimum Circuit Demand**

The demand for each HV metered demand customer at the time and date of the minimum demand of the circuit is determined and applied to the model as fixed loads.

*Example: In the circuit below the minimum circuit demand of 1.1MVA occurred at 03:00 on 19th August 2015. The circuit has two HV metered customers and during this particular half hour they were importing 0.21MVA and 0.10MVA respectively. These values are allocated to the model.*



**Figure A7 Allocation of Demands to HV Demand Connection**

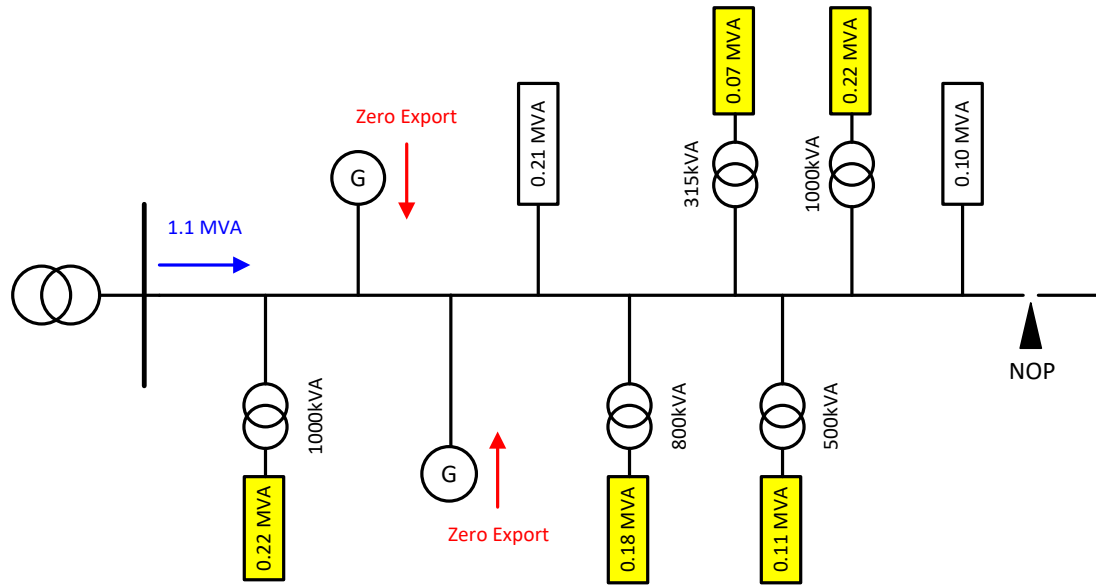
### A1.3.3 Apply Minimum Circuit Demand and Allocate Demand to Distribution Transformers

When the minimum circuit demand is applied to DINIS and the load is allocated it applies the known demand first (i.e. to the HV connections) and then apportions the remaining demand to the other substations in proportion to their transformer capacities.

*Example: The remaining demand is  $1.1\text{MVA} - 0.21\text{MVA} - 0.10\text{MVA} = 0.79\text{MVA}$ . The aggregate capacity of the distribution transformers connected to the circuit is  $3.615\text{MVA}$  and so the demand allocated to each transformer will be  $(0.79/3.615) \times 100 = 21.9\%$  of the transformer capacity.*

*In this case the following demands are allocated:*

- 1000kVA transformer = 0.22MVA each
- 800kVA transformer = 0.18MV
- 500kVA transformer = 0.11MVA
- 315kVA transformer = 0.07MVA



**Figure A8 Allocation of Network Substation Minimum Demand**

#### A1.3.4 Model all $\geq 50\text{kW}$ Generators

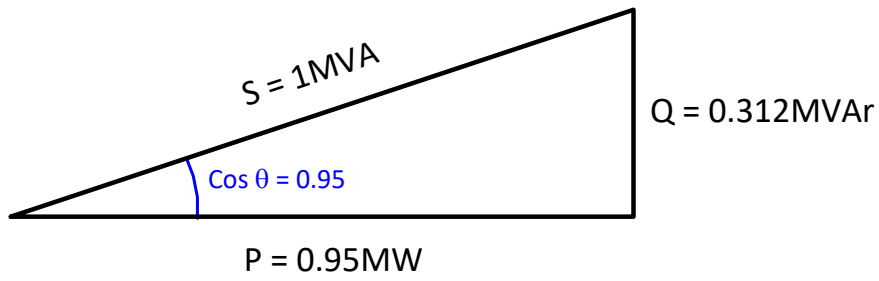
All known generation connections  $\geq 50\text{kW}$  must be identified and modelled as P-Q type generators in DINIS. The operating power factor of the generator shall be taken into account by applying the correct values of Active Power (MW) and Reactive Power (MVar) to the model. Where more than one  $\geq 50\text{kW}$  generator connection is connected to a single substation at LV the generators may be grouped together and modelled as a single generator.

Generators rated below  $50\text{kW}$  are not normally modelled but their impact will be accounted for, to some extent, as they will reduce the measured apparent power at the source circuit breaker.

Diversity is not normally applied to generators.

*Example: The circuit includes two generators. One has an agreed export capacity of 1MVA and operates at a leading power factor of 0.95 the other has an agreed export capacity of 0.3MVA and operates at unit power factor.*

*The first generator is modelled with a fixed value of active power of 0.95MW and a fixed reactive power of -0.312 MVar.*



The second generator is modelled with a fixed value of active power 0.3MW and a fixed reactive power of 0MVar.

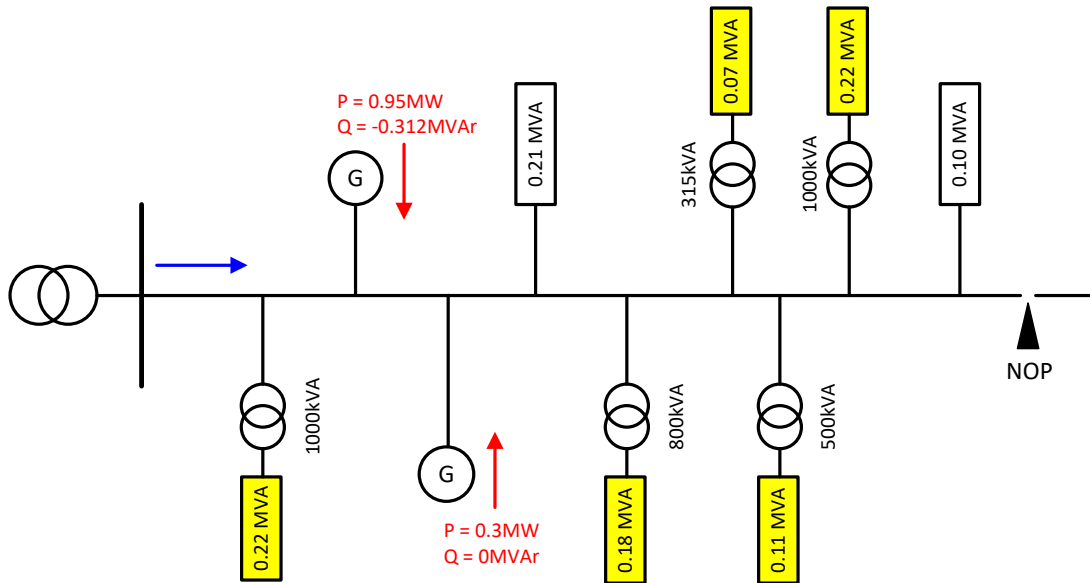


Figure A9 Generator Modelling



## **A2 Allocation of Voltage to the Network Model**

### **A2.1 Primary Substation Voltage**

Tap-change control relays measure the HV voltage (i.e. 11kV or 6.6kV) and attempt to maintain this voltage by adjusting the transformer tap-changers. The target voltage is normally a fixed value but in some cases it may be automatically adjusted as the load on the transformers alters (i.e. where load drop compensation settings are applied). This section assumes that the target voltage is set a fixed value.

In addition to a target voltage, a voltage bandwidth is set and the tap-changers are only operated when the voltage goes outside this bandwidth. This prevents the tap-changers from hunting and reduces the maintenance requirements. Typically the bandwidth is set between  $+1.25\%$  and  $-1.5\%$  of the target voltage. If the measured voltage goes outside of the bandwidth for longer than the operating time setting (typically 60 to 120 seconds) the tapchanger is operated to bring the voltage back within the bandwidth.

Figure 10 shows an example of a tap-change control relay with a target voltage of 11.3kV and a bandwidth of  $\pm 1.25\%$ .

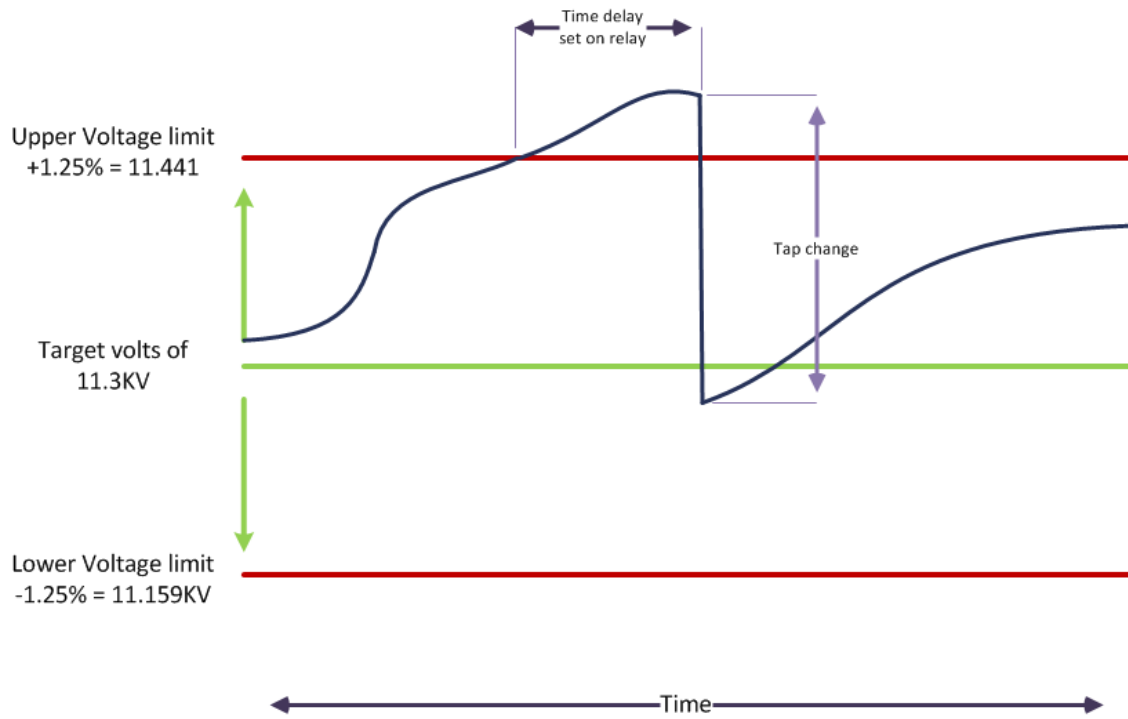
### **A2.2 Modelling**

For the maximum demand – zero generation studies, where low voltage is of concern, the voltage at the primary substation shall be modelled at the lower end of the voltage bandwidth. In the example shown in Figure A10, a value of 11.16kV would be appropriate.

For the minimum demand – maximum generation studies, where high voltage is of concern, the voltage at the primary substation shall be modelled at the upper end of the voltage bandwidth. In the example shown in Figure A10, a value of 11.44kV would be used.

### **A2.3 Determining Tap-change Control Relay Settings**

The target voltage and bandwidth settings may either be obtained from Primary System Design, Major Projects or a reasonable approximation can be obtained by analysing the voltage data using the standard logger spreadsheets.

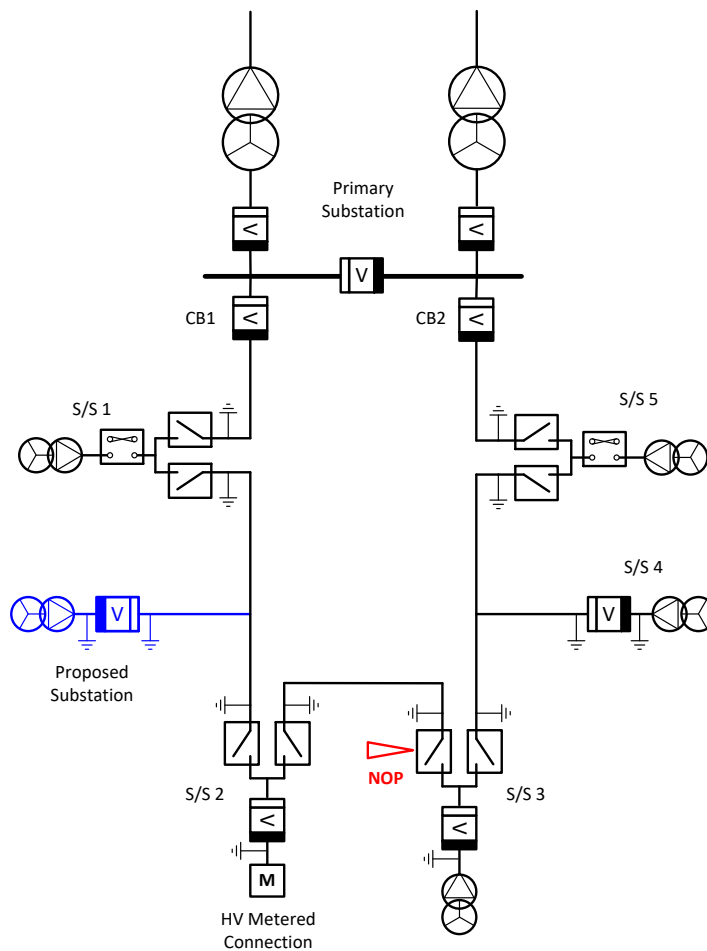


**Figure A10 Operation of Tap-change Control Relay**

EXAMPLES

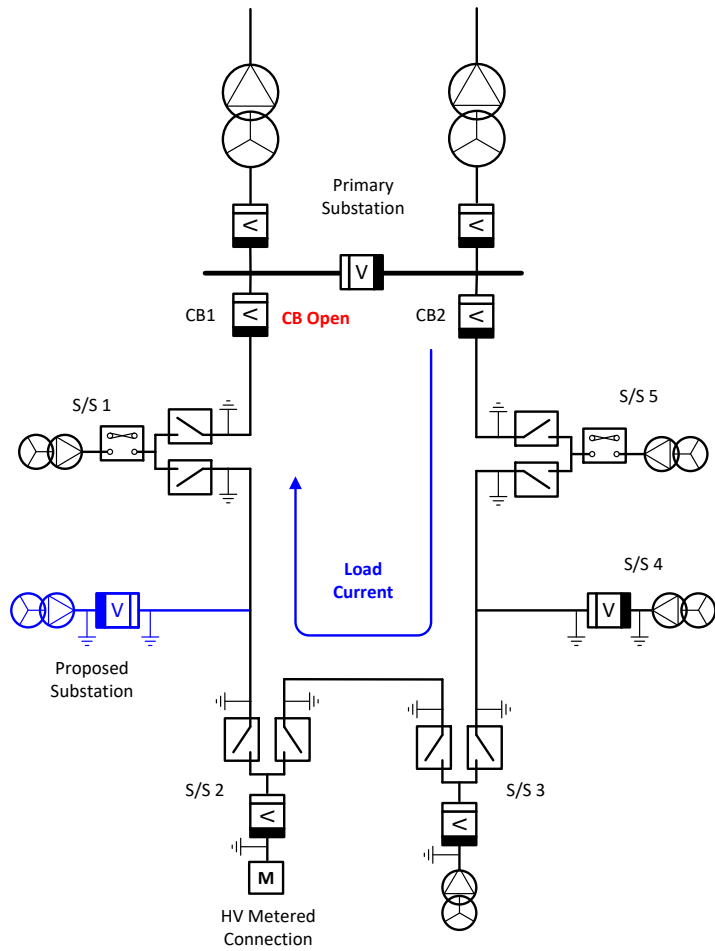
**B1 Demand Added to an HV Network**

**B1.1** A new substation is to be added to the network as shown in Figure B1. The existing target voltage is 11.1kV and the bandwidth is +/-1.25%. The existing distribution transformers are set on the +2.5% tap position. A new substation is proposed with a maximum demand of 500kVA and no generation.

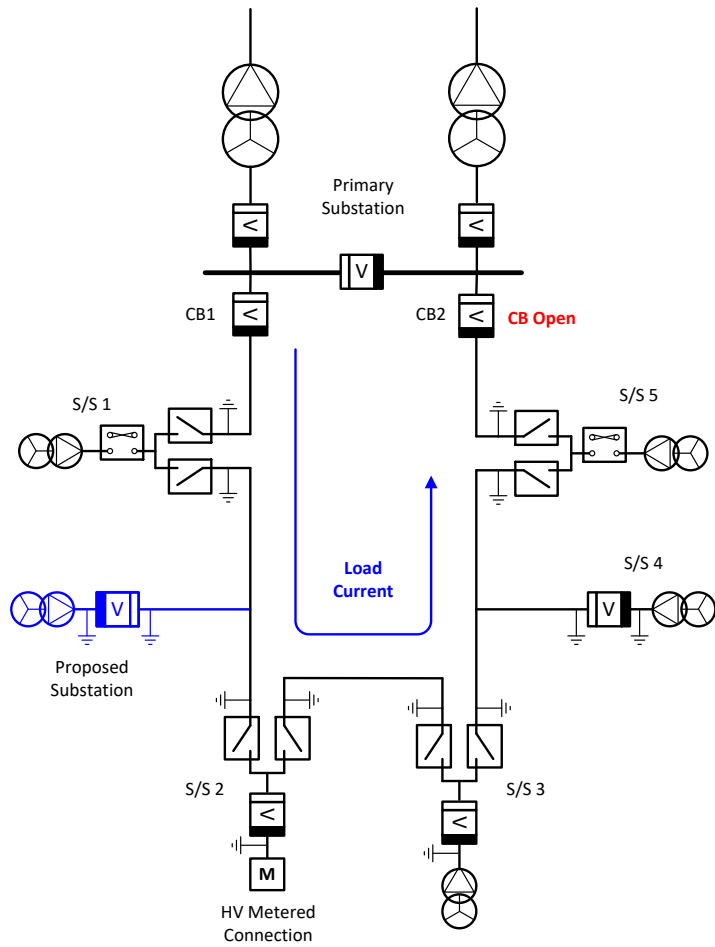


**Figure B1.1 Example B1**

- B1.2 The first stage is to set up the model for a Maximum Demand – Zero Generation study. The voltage at the primary substation is set at the maximum voltage, taking account of the nominal voltage and bandwidth settings on the tap-change control relay. In this example, a value of 11.1kV - 1.25% is used giving a voltage of 10.96kV. The maximum load is then applied and allocated in accordance with A1.2.
- B1.3 The arrangement is checked to ensure that the requirements of ENA Engineering Recommendation P2 (Security Requirements) are satisfied. In this example, the teed substations have a maximum demand of less than 1MW and for N-1 conditions the demand (with the exception of the final 1MW) can be restored within 3 hours, satisfying the P2 requirements.
- B1.4 When checking the thermal requirements, i.e. cable and overhead line ratings, switchgear ratings and overcurrent protection settings, consideration is given to the normal and expected back feed conditions. In this example, the back feed conditions are shown in Figure B1.2 (CB1 Open) and B1.3 (CB 2 Open) are considered.
- B1.5 The voltage levels are checked to ensure they meet the minimum voltage requirements specified in POL: SD4 for normal feeding arrangements and the back feed (N-1) conditions. In this example, the distribution transformers are set on +5% tap and therefore the following limits apply:
- a) HV Voltage limits for Distribution Transformers on +2.5% Tap:
    - Minimum HV voltage, normal feeding arrangement = 10.47kV
    - Minimum HV Voltage, N-1 arrangement = 10.06kV
  - b) HV Voltage limits for HV Connections:
    - Minimum HV voltage, normal feeding arrangement = 10.34kV
    - Minimum HV voltage, N-1 arrangement = 9.90kV



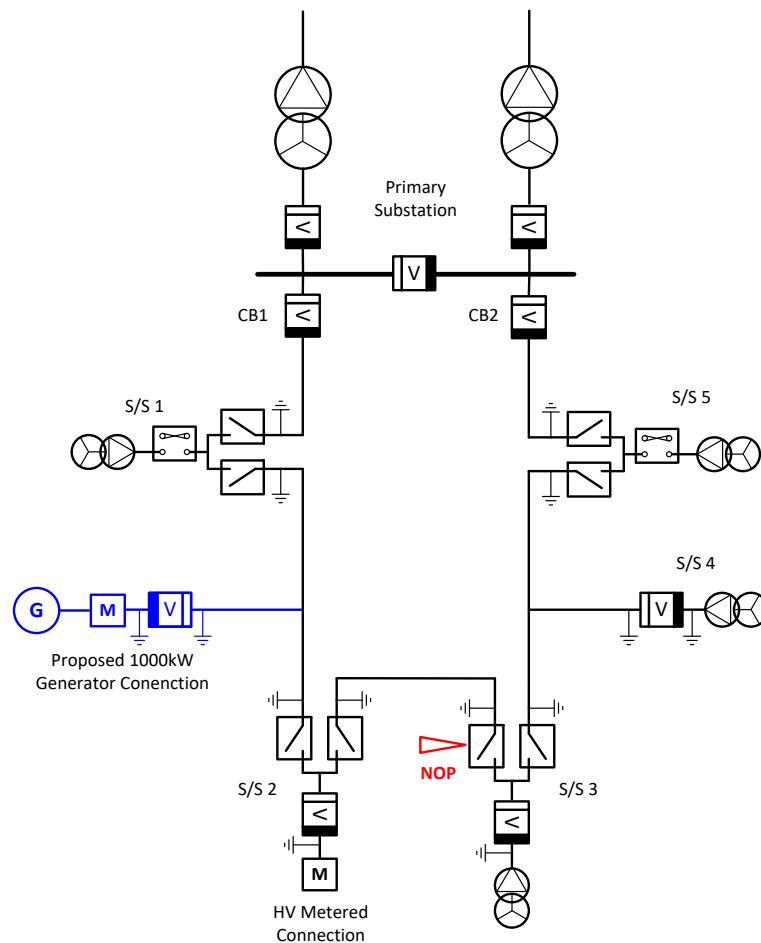
**Figure B1.2 N-1 Condition (CB1 Open and NOP Closed)**



**Figure B1.3 N-1 Condition (CB2 Open and NOP Closed)**

## B2 Generation Added to an HV Network

B2.1 In this example a 1000kW generator is proposed to be added to the existing network as shown in Figure B4. In all other respects the network is identical to network considered in section B1.



**Figure B2.1 Example B2**

B2.2 If the proposed connection has a significant Agreed Import Capacity this is considered using the Maximum Demand – Zero Generation method described in section B1.

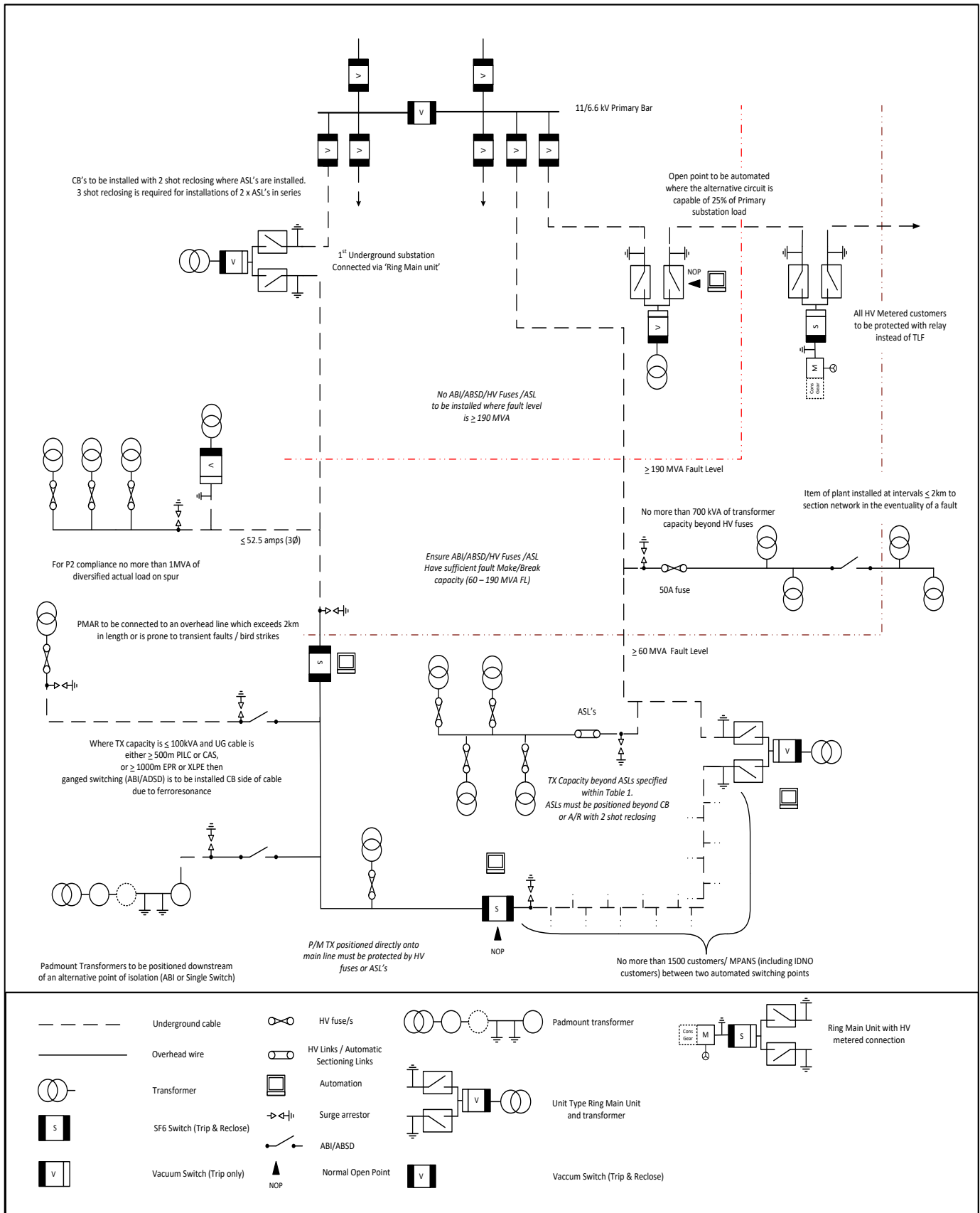
B2.3 In order to study the impact of the generation (i.e. the export capacity) a Minimum Demand – Maximum Generation model is set up as described in A1.2. The voltage at the primary is set at the top of the tap-change control relay's bandwidth, i.e.  $11.1\text{kV} + 1.25\% = 11.24\text{kV}$ . The minimum demand is added and allocated and then all the  $\geq 50\text{kW}$  generators are added to the model.

- B2.4 ENA Engineering Recommendation P2 does not normally apply to generation and so, as far as the export capacity is concerned, supply security under N-1 conditions is not considered
- B2.5 The thermal requirements including the cable and overhead line ratings, switchgear ratings and overcurrent protection settings are checked for the normal feeding arrangement. Thermal requirements for abnormal conditions are only considered if the generator specifically requests a firm connection.
- B2.6 The voltage levels are checked to ensure they meet the maximum voltage limits specified in POL: SD4 for the normal feeding arrangement and back feed (N-1) conditions. In this example, the distribution transformers are set on +2.5% tap and therefore the following limits apply:
- a) HV Voltage limits for Distribution Transformers on +2.5% Tap:
    - Maximum HV Voltage = 11.31kV
  - b) HV Voltage limits for HV Connections:
    - Maximum HV voltage = 11.66kV

Where the generator is provided with a non-firm connection and the voltage limit is satisfied under the normal feeding arrangement but exceeded under back-feed conditions, a generator constraint panel should be fitted that operates in a Voltage Constraint mode, assuming the generation is rated at 500kW or higher. ST:TP18A provides further guidance on Generator Constraint Panels.



Example configuration of a HV network



High Voltage Design - Design Submission form



Site Address	
Designer	
Company Name	
WPD Auditor	
Managed Unit	

External Enquiry No	
Internal Enquiry No	
Date	

Requested load (demand only)		kW
Number of MPAN's to be created		
Power Factor		
Load profile - cyclic or sustained?		
Any motors / generators $\geq$ 50kW? *		Y/N

Connecting onto circuit no -

Rating of primary transformers		MVA
Load on primary substation		MVA
Single transformer primary? **		Y/N
Apportionment or Potential refund symbols? ***		Y/N

Relevant backfeed circuits -


Design Parameters

Date & Time of maximum demand		
Network load profile - Cyclic or Sustained?		
Season with highest utilisation factor		
Target voltage of primary S/S		kV
Band width of primary S/S tap changer relay		%
Primary voltage used for calculations		kV
Tap position on distribution substations		%
Target voltage of alternative Primary S/S ****		kV
Band width of alternative S/S tap changer relay ****		%
Alternative primary voltage used for calculations ****		kV

Load on Circuit  kVA

Load on Backfeeds

		kVA
		kVA
		kVA
		kVA
		kVA
		kVA

Network analysis checks

Normal running arrangement

Current flow at POC		A
Voltage at new transformer		kV
Lowest voltage on circuit		kV
Location of lowest volts		
Highest utilisation Factor		%

Abnormal running arrangement

Current flow at POC		A
Voltage at new transformer		kV
Lowest voltage on network		kV
Location of lowest volts		
Highest utilisation Factor		%

Security of Supply (ENA ER P2)

Is the group demand < 1MVA		Y/N
Does the whole circuit comply with P2?		Y/N
Is this circuit an essential backfeed?		Y/N
Does the circuit and connection comply with ST:SD4A?		Y/N
Circuit Backfed from. Open point switched at		

→ Backfeed for circuit

Attachments to be included

- 2 x HV schematic detailing the normal and abnormal circuit connectivity.
- 2x HV schematics detailing the Point of Connection including the customer equipment

Is reinforcement required?

comments

\* Where motors or generators are installed with a rating  $\geq$  50kW, consideration must be given to the fault rating of apparatus and a fault level study maybe required  
 \*\* Only WPD to calculate the POC for connections on circuits with Single transformer primaries on the normal or abnormal feed  
 \*\*\* Only WPD to calculate the POC for connections where Apportionment or Potential Refund are applicable  
 \*\*\*\* Only required where the alternative backfeed is fed from an another Primary substation

## APPENDIX E

### SUPERSEDED DOCUMENTATION

This document supersedes ST: SD4A/3 dated December 2018 which has now been withdrawn.

## APPENDIX F

### RECORD OF COMMENT DURING CONSULTATION

[ST: SD4A/4 - Comments](#)

## APPENDIX G

### ANCILLARY DOCUMENTATION

Electricity Supply Regulations 1988  
Distribution Code  
Electricity at Work Regulations 1989  
Health and Safety at Work Act 1974  
ENA EREC G5 Harmonic Voltage Distortion  
ENA EREC G59 Recommendations for the Connection of Generation to the Distribution System  
ENA EREC G75 Recommendations for the Connection of Generation >20kV and/or >5MW  
ENA EREC G99 Requirements for the Connection of Generation to the Distribution System  
ENA EREC P2 Security of Supply  
ENA EREC P28 Voltage Fluctuations  
ENA EREC P29 Voltage Unbalance  
ENA TS 35-1 Distribution Transformers (from 16kVA to 2000kVA)  
EE SPEC:5 regarding 11kV Distribution Transformers  
ST: OC1T regarding Ferro Resonance  
ST: OS2D regarding Operation of Pole Mounted Equipment  
POL: SD4 regarding High Voltage System Design  
ST: SD1G regarding Communication Requirements for Generation Sites  
ST: SD4O regarding HV Connection Arrangements  
ST: SD4T regarding Provision of data to ICP's  
ST: SD6T regarding Improving Voltage and Current Unbalance  
ST: SD8A regarding Overhead Line Ratings  
ST: SD8B Part 2 regarding HV Underground Cable Ratings  
ST: SD8D regarding Distribution Transformer Ratings  
ST: TP4B regarding 11kV and 6.6kV Transformer Protection  
ST: TP18A regarding Voltage Constraint Panels

## APPENDIX H

### KEY WORDS

HV network Design, HV network Analysis, DINIS