

## SENSITIVITY ANALYSIS OF FAULT LEVEL ASSESSMENTS IN HV NETWORKS

Ali KAZEROONI  
Parsons Brinckerhoff – UK  
[Ali.kazerooni@pbworld.com](mailto:Ali.kazerooni@pbworld.com)

Samuel JUPE  
Parsons Brinckerhoff – UK  
[JupeS@pbworld.com](mailto:JupeS@pbworld.com)

Jonathan BERRY  
Western Power Distribution - UK  
[jberry@westernpower.co.uk](mailto:jberry@westernpower.co.uk)

Neil MURDOCH  
Parsons Brinckerhoff – UK  
[Neil.Murdoch@pbworld.com](mailto:Neil.Murdoch@pbworld.com)

### ABSTRACT

*In this paper, the effects of the accuracy of HV network parameters on calculated make and break fault levels are investigated. Fault level calculations, using computer models, are an approximation to the behaviour of the actual distribution network and, due to assumed parameter values, include a level of inaccuracy. The results of the fault level sensitivity analysis studies show that the network parameters which have a greater impact on pre-fault voltage levels need to be modelled more accurately. In addition, the fault level sensitivity to general load fault in-feed assumptions given in engineering recommendations is studied. Based on the sensitivity analysis results, recommendations for modelling the HV networks and architecture of a fault level active management system are proposed.*

### INTRODUCTION

Growing connections of low-carbon generation to urban distribution networks can increase the fault level of the network, requiring upgrades to electricity network assets. Network upgrades can be prohibitively expensive or entail a long lead time, which can affect the timely connection of distributed generators into the network. The UK aims to have 30% of its electricity provided by renewable sources by 2020 [1]. Birmingham Central Business District (CBD), in the UK, has been identified as an area where a high level of integration of combined heat and power (CHP) plants is expected in HV networks<sup>1</sup> by 2026. As a result of the anticipated level of CHP integration, the fault levels in HV networks could exceed the short circuit ratings of the switchgear. Smart solutions are being demonstrated, as an alternative to traditional network upgrade solutions, in a £17.1m Low Carbon Networks Fund project in the UK, FlexDGrid [2]. FlexDGrid aims to enhance fault level modelling and calculation processes, demonstrating different fault level mitigation technologies in existing primary substations (132kV/11kV) in Birmingham.

FlexDGrid will propose the solutions which will defer network reinforcement, unlocking capacity for low carbon technologies (such as CHP plants) to be integrated into HV networks.

As part of the enhanced fault level assessment process within FlexDGrid, the assumptions that underpin fault level calculations were explored and a questionnaire was conducted to understand the consistency of application of fault level calculation standards amongst distribution network operators (DNOs) in the UK [3]. The outputs of these questionnaires supported the need to understand the sensitivity of calculated fault levels to different parameters of an electricity network model, as well as the assumptions considered in standards and engineering recommendations.

Engineering Recommendation (ER) G74 [4] is used by UK DNOs to implement fault level calculations based on the IEC 60909 standard [5]. When implementing ER G74, the pre-fault voltage conditions of the network are determined through a load flow simulation. Fault levels are more sensitive to those parameters which have a greater impact on the calculated pre-fault voltage levels. The operating condition of the generators, tap changer position, network impedance and estimated load demand are among those parameters that may affect the pre-fault voltage levels.

The sensitivity analysis methodology has been implemented on sample HV feeders in Birmingham's CBD. The model parameters are varied within defined ranges and the sensitivity of the calculated fault levels (Making and Breaking) is calculated for each model parameter input to the ER G74 fault level calculation process. The main applications for fault level sensitivity analysis are:

- Identifying the parameters of the network model which need to be measured with precision and estimated with a high level of accuracy;
- Determining the effect of assumptions recommended in ER G74 on calculated fault levels, and identifying any areas of review required in ER G74.

<sup>1</sup> The high voltage (HV) network refers to the 11kV network.

- Developing recommendations on network operation schemes and commercial frameworks which result in a reduction in the fault levels on 11 kV networks and facilitate the increased integration of distributed generators; and
- Improving the accuracy of desktop analysis through the adjustment of model parameters which have a high impact on fault level. This application is important for the validation of monitored fault level values.

The remainder of this paper is organized as follows. First, a review of the assumptions and process for fault level calculation using a computer model is presented, along with the assumptions recommended in ER G74. Next, the methodology used for fault level sensitivity analysis is presented. Following this, the results of sensitivity analysis are presented and discussed. A possible architecture for an active network management system is discussed and finally, concluding remarks and recommendations are presented.

## COMPUTATIONAL ANALYSIS OF FAULT LEVEL

The fault level assessment is usually carried out using a computer model of the electricity network. A key learning point from the UK DNOs survey was that, for HV network fault assessments, only the HV network is modelled in detail and equivalent models are used for downstream (LV) and upstream networks (EHV). The computer models represent a snapshot of the network conditions for the worst case (highest) fault levels.

IEC 60609 is widely utilised for fault level calculations by DNO and Transmission network operators companies. Engineering Recommendation (ER) G74 is used by UK DNOs to implement the IEC 60909 standard for desktop fault level calculations. One of the differences between ER G74 and IEC 60609 is the pre-fault voltage conditions assumed for fault level calculation. IEC 60609 recommends a conservative approach using 'C factor' multipliers, which create artificially high network voltage levels for fault current calculation, whereas ER G74 utilises the calculated pre-fault voltage levels from a power flow analysis.

The pre-fault voltage levels are affected by the model parameters of the network. Every component of the computer model has associated bands of accuracy. The degree to which the components' values can vary affects the pre-fault voltage levels and consequently the calculated fault levels. In this paper the following network parameters and assumptions which can have a high impact on voltage levels and fault levels are considered:

- Generators' operating power factor
- Circuit impedance
- Tap changer position
- General load fault in-feed
- Demand

### Network model parameters

#### Generator power factor

The power factor at which a generator operates has an impact on the fault current contribution of that generator. The internal voltage and the impedance (sub-transient/transient) of a generator determine the fault current contribution from the generator. The generator's internal voltage, however, has a vector relationship with the pre-fault voltage at the connection point and the pre-fault generator output current. Figure 1 shows a Thevenin model of a single generator connected to the network. In Figure 1,  $V_s$  is the internal voltage,  $X_s$  is the synchronous impedance,  $V_T$  is the voltage at the generator's connection point to the network and  $I_G$  is the output current of the generator. The vector relationships between these variables, when the generator operates in different power factors, are shown in Figure 2. The magnitude of the generator's internal voltage is greater than the voltage at the connection point when a generator operates in lagging and unity power factor, whereas in leading power factor the internal voltage is lower than the network's voltage.

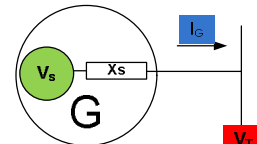

Figure 1: Thevenin model of a generator connected to the network

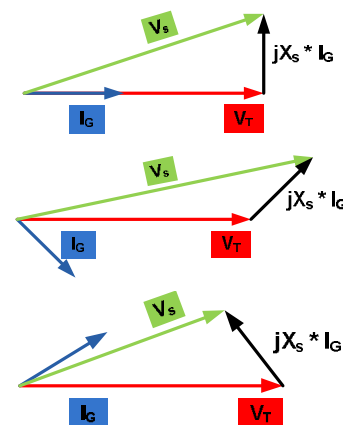

Figure 2: The vector calculation for generator internal voltage when it operates at (from top to bottom) Unity power factor, Lagging power factor, and Leading power factor

It should be noted that the generator operation power factor can affect the network voltage ( $V_T$ ), however, network voltage depends on the operating conditions of all network components. Therefore, in a real system, different operating power factors versus different network voltages can be envisaged.

Figure 3 shows the variation in initial rms fault current contribution for a 1 p.u. rated output generator when it operates at different network voltage levels and power factors.

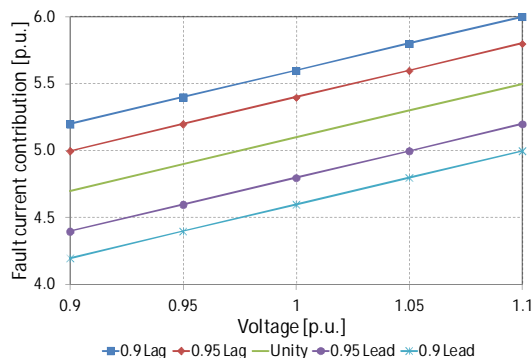

Figure 3: The effect of power factor on generator initial rms fault in-feed (The sub-transient reactance of the generator is assumed to be 0.20 pu)

### Circuit impedance

The circuit length or impedance of a network model has sources of uncertainty, resulting in levels of inaccuracy. This inaccuracy can stem from:

- Ageing effects of conductor on the actual circuit length and the conductor electrical parameters (e.g. resistance and reactance);
- Inaccurate estimated lengths of conductor for each circuit section (line sag and the terrain slopes in the trajectory of cables may be neglected);
- Assumed types of conductors, which may be incorrect (when conductor type records for part of a network are missing or conductor databases are not accurately maintained).
- Assumed resistance; whether “cold DC” or “hot AC”.

### Tap Changer Positions at primary substation

Transformer tapping is a regular operational exercise to maintain the voltage profile on the network within the acceptable limits. The position of the tap at the upstream substations can alter the voltage profile of the network and consequently the fault current contributions. The actual position of the tap changer, when a fault occurs in the network, may differ significantly from the modelled position. The impedance of the transformer may also change for different tap positions.

### General load fault in-feed

The load demand on the network consists of rotating machines which can contribute to fault level. Modelling all the rotating machines is difficult and time consuming. ER G74 states “where measured values are not available, the following indicative allowances can be used for calculating the initial three-phase symmetrical RMS short-circuit current contribution at a 33kV busbar from the asynchronous motors in the general load supplied from that busbar: For load connected to the supply network at (i) low voltage, allow 1.0 MVA per MVA of aggregate low voltage network substation winter demand; (ii) high voltage allow 2.6 MVA per MVA of aggregate winter demand. These contributions relate to a complete loss of supply voltage to the motors.”. This assumption may need to be revisited due to variations in load composition since 1992 when ER G74 was first published. It is also not clear how the general load fault contribution would differ when alternative voltage levels are considered (for example at 11kV and 6.6kV).

### Demand

The calculated voltage profile can be affected by the magnitude of the estimated demand in a network model. For the purpose of network studies in extreme conditions, the maximum or minimum aggregated load is usually estimated and modeled at the distribution (HV/LV) substation. The accuracy of the estimated load may be affected due to lack of information and recorded loadings of distribution substations. In addition, It is important that the demand accurately reflects true demand, not merely “demand - embedded generation”. It is expected that some degree of inaccuracy in calculated voltage profile and fault level stems from the inaccuracy in estimated demand.

### METHODOLOGY

An electricity network computer model represents a snapshot of the network operational conditions. If the network model parameters are changed from their original values, the model representation will deviate from the original operational condition. For the purpose of the sensitivity analysis, a PSS/E model of a sample network, representing part of Birmingham’s 11kV network, has been considered, as given in Figure 4. Feeder A and Feeder B represent a long feeder and a short feeder respectively. These feeders are supplied by an upstream 132/11kV primary transformer. Four generators with a total capacity of 4.6 MVA and stochastic connection points are assumed in the sample model. All generators are operating at 0.415kV (at unity power factor) and are connected to the 11kV network with 11/0.415kV transformers. The total demand supplied through feeder A and feeder B is 4.74 MVA and 1.56 MVA respectively.

The parameters of the sample model have been varied within an assumed range to create different network conditions scenarios. The corresponding fault current contributions to the 11kV busbar at the primary substation, point M1 in Figure 4, are calculated for each scenario. The results are then compared with calculated fault contributions from the original model to understand the impact of each network parameter on the fault level. The variation ranges of the network parameters are as follows:

*Generation power factor (PF):* Unity, 0.95 leading, 0.95 lagging

*Circuit impedance:* 5% to + 5% from original value

*Tap position at Primary Substation:* Voltage at 11 kV busbar changes between 0.95 per unit to 1.03 per unit

*General load fault in-feed:* 0 to 2 MVA per MVA of load

*Demand:* 10% to + 10% from original value

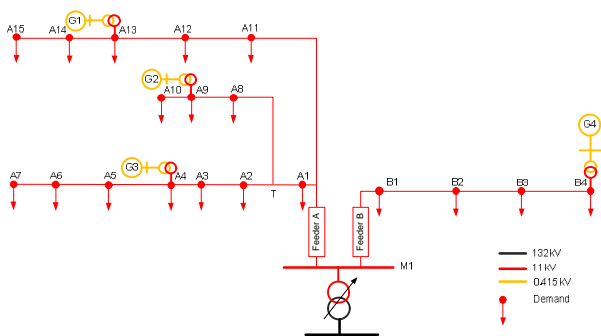

Figure 4: The sample model representing a short and a long feeder

Part of the general load consists of asynchronous machines which contribute to the fault level (both Peak Make and, potentially, rms Break). According to ER G74, the initial rms fault contribution from the general load connected to the low voltage network is around 1 MVA per 1 MVA of load when aggregated at 33kV. In a computer model, the fault contribution from general load is usually modelled with an equivalent generator at the 33kV or 11kV points where the aggregate load is connected. For the purposes of this study, 1 MVA per MVA of load has been applied at 11kV using an X/R ratio of 2.76.

## RESULTS AND DISCUSSION

The fault level sensitivity analysis shows that different parameters of the network model have different effects on the making and breaking fault currents. Figure 5 summarises the results of the sensitivity analysis and shows the average variations in the fault current contributions from the HV network to busbar M1, the 11kV busbar at the primary substation, against different

model parameters of the sample network.

The results of the sensitivity analysis show that the generation power factor has the largest effect on the fault current, the Peak Make and rms Break fault current change by around 7% when the generator's power factor changes from unity to 0.95 lead. In addition, the analysis shows that demand can have the lowest impact, less than 1%, on both breaking and making fault current.

Demand variation affects the network voltage profile and general load fault in-feed. These two have opposite effects on fault levels. Increasing demand may result in lower voltage profiles along the network and consequently a lower fault current. However, the general load fault in-feed (1 MVA fault contribution for every 1 MVA load) increases if demand increases.

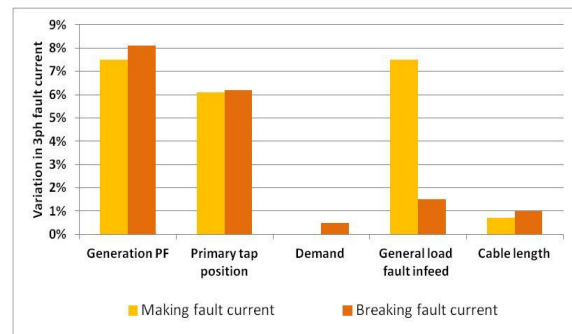

Figure 5: Summary of sensitivity analysis results

## ACTIVE FAULT LEVEL NETWORK MANAGEMENT APPLICATION

Fault level monitoring in conjunction with a “connect and manage” scheme is one of the solutions to expedite the connection of flexible customers (for example, distributed generators) and defer network asset upgrades. For the purpose of active fault level management, under a “connect and manage” scheme the flexible customers can be disconnected when the monitored fault level at the upstream substation is close to exceeding the fault level limits. In a more flexible scheme, based on what was learnt from sensitivity analysis, the operating power factor of the generator as well as upstream transformer tap position can be controlled to reduce the fault level rather than disconnecting the customer as the first action.

The architecture of a closed-loop active fault level management system is shown in Figure 6. The fault level monitoring (FLM) technology informs the active network management (ANM) system about the fault level at the primary substation. If the fault level exceeds a pre-set limit, control commands are communicated to the distributed generators to operate in leading power factor.

In addition, as a primary action, by controlling the tap position at the primary substation, the voltage across the 11kV network can be reduced. Voltage regulation at primary substations is also being trialled as a solution to demand control [6], but it has rarely been used in ANM systems for the purposes of the fault level management.

It should be noted that in some networks there is not enough room for voltage control corrective actions because of the voltage limits in the LV network. In addition, voltage stability issues may arise due to operating generators in leading power factor. These issues can be controlled by defining permissible voltage limits at the primary substation and other parts of network. The voltage and currents at different points of the 11kV network will be also monitored to ensure they do not exceed the statutory limits. As an ultimate solution to fault level control the distributed generators can be tripped if using corrective actions (transformer tapping or generation power factor control) may results in any voltage or thermal rating violation.

Further work is in progress within FlexDGrid to develop a commercial framework based on the learning from the sensitivity analysis, active fault level monitoring and other UK DNOs' experience in deploying "connect and manage" schemes.

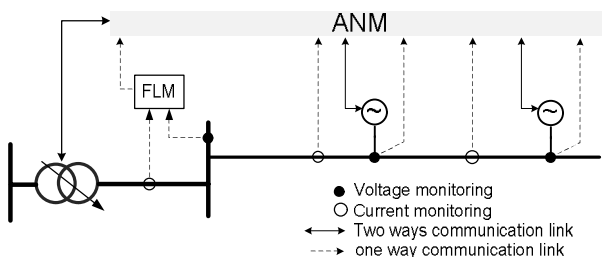

Figure 6: Architecture of an active fault level management system

## CONCLUSION AND RECOMMENDATIONS

Fault level calculations, using computer models, are an approximation to the behaviour of the actual distribution network and, due to assumed parameter values, include a level of inaccuracy. The impacts of inaccuracy in network model parameters, on the calculated fault level in HV networks, were studied in this paper. The results showed that generation power factor and tap position of the transformer can have a large effect on voltage profile and, consequently, the calculated fault level. Based on the sensitivity analysis, the following recommendations may be considered.

1. It is recommended that a detailed model of the HV network is used for generation connection studies. This allows pre-fault voltage conditions to be calculated more accurately, resulting in more accurate calculated fault levels. Using equivalent network models is likely to result in a higher calculated fault level;
2. In order to calculate fault currents as accurately as possible, it is recommended that a generator's model represents the actual power factor at which it is set to operate. Nonetheless, for worst case fault level calculation, it is recommended that generators are modeled in unity power factor;
3. The tap position at Primary Substations has a large effect on the calculated fault currents. It is recommended that care should be taken to model the tap at the position which results in a network voltage profile representing the system condition in real-life; and
4. General load has a effect on the making fault current. It is recommended that large synchronous and asynchronous motors (or large concentrations of such motors) are modelled if possible. It is also recommended that work is carried out to understand the load mix and appliances used by low voltage connected customers. The ER G74 recommendation on general load fault in-feed may need to be reviewed.

## REFERENCES

- [1] UK Government, *The carbon plan: delivery our low carbon future*, December 2011
- [2] FlexDGrid, Western Power distribution, URL: <http://www.westernpowerinnovation.co.uk/FlexDGrid/FlexDGrid-Project-Aims.aspx>
- [3] S. Jupe, A. Kazerooni, *Simulation and applying enhanced fault level assessment processes*, Western Power Distribution, 2013. URL: <http://www.westernpowerinnovation.co.uk/Documents/FlexDGrid-SDRC4-report-and-appendices.aspx>
- [4] "IEC International Standard for Short-circuit currents in three-phase a.c. systems - Part 0: Calculation of currents", IEC 60909-0, Jul. 2001.
- [5] Energy Networks Association, *Procedure to meet requirements on IEC 909 for the calculation of the short circuit currents in three phase AC power systems*, Engineering recommendation G74, 1992.
- [6] Electricity North West, *CLASS voltage regulation scheme*, 2014.