

IMPLEMENTATION OF AN ACTIVE FAULT LEVEL MONITORING SYSTEM FOR DISTRIBUTED GENERATION INTEGRATION

Jonathan BERRY

Western Power Distribution – UK

jberry@westernpower.co.uk

Samuel JUPE

Parsons Brinckerhoff – UK

JupeS@pbworld.com

Mike MEISINGER

S&C Electric Europe Ltd – UK

mike.meisinger@sandc.com

John OUTRAM

Outram Research Limited – UK

johnoutram@orll.com

ABSTRACT

This paper describes the practical implementation of an active fault level monitoring system to facilitate the integration of distributed generation (DG) within 11kV distribution networks. The system is being tested in the UK by a consortium comprising Western Power Distribution, Parsons Brinckerhoff, S&C Electric Company and Outram Research Limited. Laboratory tests were conducted for a variety of system fault levels and network running arrangements. Results from the laboratory tests showed that the fault level was consistently predicted to be within 4.5% of measured three-phase faults applied to the system.

INTRODUCTION

The increase in fault level contribution from rotating machines is a significant barrier to the connection of new synchronous generators, for example combined heat and power (CHP) units, within 11kV networks [1]. In order to ensure the integrity of the power system, fault levels need to be maintained below equipment ratings. Current network reinforcement options would involve the replacement of switchgear with higher-rated equipment or replacement of transformers with a higher impedance core. These solutions often entail significant capital expenditure and may involve long lead times for installation, delaying the connection time of generators on to the network.

Fault level is a measure of electrical stress when an unintentional conducting path (fault) causes a short circuit. This causes potentially very high fault currents to flow in the electricity lines, cables and substation equipment. The amount of fault current varies from location to location; depending on how electrically close the fault is to the energy sources (for example a transformer or rotating plant).

This paper describes the development and testing of an active fault level monitoring system to facilitate the integration of distributed generation (DG) within 11kV distribution networks. The system is being laboratory tested and subsequently field tested in the UK by a consortium comprising Western Power Distribution, Parsons Brinckerhoff, S&C Electric Company and Outram Research Limited.

The UK electricity network regulator, Ofgem, has established the Low Carbon Networks (LCN) Fund to support projects, sponsored by the distribution network operators (DNOs), to trial new technology, operating and commercial arrangements [2]. For the purposes of this project, through the LCN Fund [3], two existing products have been combined to provide fault level predictions in real-time: S&C Electric's IntelliRupter[®] PulseCloser and Outram Research Limited's PM7000 Fault Level Monitor (FLM). An IntelliRupter[®] PulseCloser is an intelligent electric switching device that, in normal operation, is used to detect, interrupt, and isolate faults. The PM7000 is an electricity network device that monitors power quality. The PM7000 provides a hardware platform for fault level monitoring and prediction algorithms.

This project aims to demonstrate the feasibility of real-time fault level predictions to facilitate quicker and more cost-effective DG connections, permitting an increase in power supplied from renewable energy sources whilst managing the fault level to avoid exceeding equipment ratings. Moreover, the system could allow the network to be operated in a more secure configuration. In addition, the project will also improve the practical understanding of how close simulated fault levels are to actual values. System studies can result in pessimistic fault level calculations [4] and an active monitoring system overcomes the drawbacks associated with passive monitoring techniques.

BACKGROUND

Driven by UK Government policy [5], the increasing requirement to connect new DG (such as renewable and CHP) to distribution networks will impact on the operation of the network in a number of areas including voltage levels and fault levels. In some cases this could result in the fault level exceeding the design limit of the network equipment unless actions are taken to mitigate this issue [6].

The contribution of induction machines to short-circuit currents can be significant and must be considered when evaluating system fault levels. Standard procedures for calculating short circuit currents of induction machines require detailed machine data, which may not be available. Moreover, the results obtained using standards may lead to conservative design and unnecessary expense [4].

At present, industry standards use assumed 33kV fault in-feed values of 1 MVA per MVA of aggregate low voltage network connected winter demand and 2.6 MVA per MVA of aggregate winter demand connected at 11kV. These values relate to a complete loss of supply voltage to the motors [7]. The industry currently uses conservative models to calculate fault level. Little work has been done in the past to justify the calculated values of short circuit currents and there is some belief that the values obtained are unduly pessimistic [8]. Calculations in IEC60909 tend to include a safety margin of up to 10% [9]. It is not practical to apply a full short circuit in order to measure the fault current. Therefore, at present, there is limited visibility of true network fault level and how this changes on a real-time basis.

Fault level monitoring techniques can generally be categorised as passive, active or hybrid. Passive techniques use naturally occurring system disturbances to estimate the fault level [10]-[12]. Devices that solely rely on naturally occurring system disturbances have the inherent advantages of not needing ancillary hardware and consequently can be used at other voltage levels. They are potentially adequate for planning processes [13], however; these types of devices have limited application in the real-time management of fault level. This is because the occurrence of natural disturbances within the electricity network is unpredictable and, on this basis, insufficient to guarantee the regular fault level measurements that would be needed in a real-time monitoring system. This limitation is overcome by devices that use active or hybrid fault level monitoring techniques. Active techniques create temporary but reduced short circuit currents on a periodic basis or inject harmonic currents around the frequency band of the fundamental frequency [14]. Hybrid techniques [15] use artificial and controlled network disturbances, potentially supplemented with natural disturbances [3], to measure the fault level.

Currently there is a limited range of devices available that allow any of these techniques to be deployed within distribution networks.

OVERVIEW OF THE REAL-TIME FAULT LEVEL MONITORING SYSTEM

This paper describes the implementation of a hybrid device to measure fault level in which two existing products have been combined to provide fault level predictions in real-time: S&C Electric's IntelliRupter and Outram Research Limited's PM7000 Fault Level Monitor.

Using the control functionality of the IntelliRupter, an artificial change in network operating conditions is created. The switching operation has the same effect on the electricity network as a motor or generator connecting to the network and being switched on and off. The change in network running conditions, whether natural or artificial, is detected by the PM7000 Fault Level Monitor and the fault level is predicted. The system is expected to deliver a fault level monitoring solution for 11kV electricity networks that, due to the IntelliRupter's pulse-closing functionality, will not affect the quality of supply delivered to electricity end users (consumers). For this reason, a 20Ω inductance was introduced into the IntelliRupter switching circuit, as shown in Figure 1.

TEST PROCEDURE

11kV, 50Hz factory acceptance tests were carried out at the S&C Advanced Technology Center in Chicago during July 2012. The factory acceptance test set-up is given in Figure 1. In order to represent a variety of credible network operating conditions, the testing procedure took place in the following way: The system was configured through the closure of switches CB₁ and CB₂ to apply the IntelliRupter and 200A load. For tests without the 200A load connected, CB₂ and switch S₂ were closed. The generator, G, represents a fault in-feed source that could be varied (5.09kA – 13.1kA symmetrical RMS) and injected into the system by the closure of making switch MS₁.

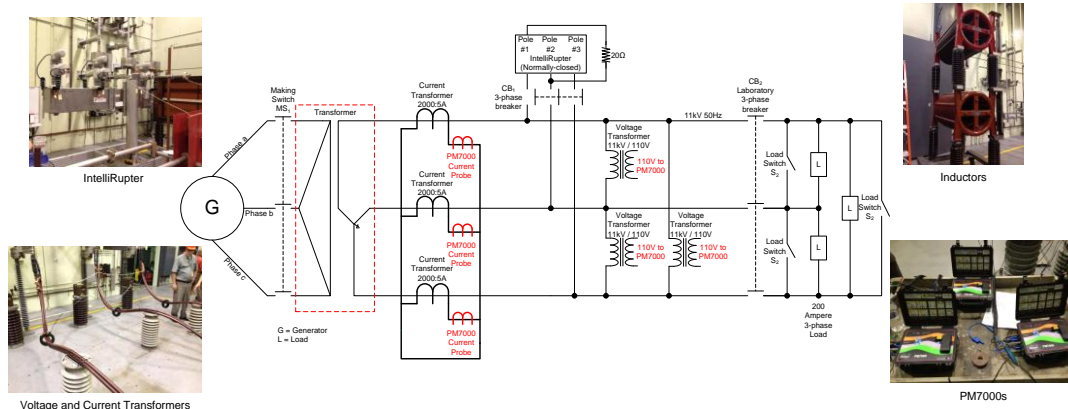

Figure 1: Factory acceptance test set-up

The generation source and transformer configuration were varied to provide a range of different X/R ratios (13.3 – 30.0). With the fault in-feed source applied to the network, the IntelliRupter performed a controlled switching operation to connect and disconnect a 20Ω inductance across phases a and b for two ¼ cycles (5ms).

For each test configuration, the PM7000 was used to monitor the voltage and current waveforms, using voltage transformer (VT) and current transformer (CT) sensors to detect the system disturbances introduced by the IntelliRupter operation. In this way, the fault level monitoring system was used to predict the fault level of the test network. In order to validate the accuracy of the fault level monitoring system predictions, a three-phase fault was applied to the network for each test configuration and the predictions were directly compared to the measured fault level.

TESTING RESULTS

Fault level prediction

A selection of test results are summarised in Table 1. The greatest difference between measured and predicted fault levels was 4.5%. This result occurred for the 90ms RMS fault level prediction, when the test network was configured with an X/R ratio of 30 and 200A load was connected to the

system. Across a range of test conditions, the average percentage difference for both 10ms peak and 90ms RMS fault level predictions was 2.7%.

Power quality effects

In order to ensure that the fault level monitoring system complies with power quality standards for voltage fluctuations (ER P28) [16] and harmonic distortion (ER G5/4-1) [17], the waveforms were observed and analysed. As given in Table 1, the greatest voltage step change was 2.76% for the system conditions with a measured 10ms peak fault level of 31.34kA without the 200A load connected. ER P28 prescribes a general limit of 3% on the allowable magnitude of voltage changes. The average percentage voltage deviation was 1.84% for the test cases considered. As given in Figure 2, the change in total harmonic distortion (THD) varies between 2.2% and 4.7% for the a-b and c-b phases of the network, respectively.

DISCUSSION

The integration of the PM7000 Fault Level Monitor and IntelliRupter within 11kV networks represents a novel step, which provides the total fault current contribution, without necessarily needing the exact detail of the elements which contribute to this total. The equipment overcomes the drawbacks associated with other passive and active devices.

X/R Ratio (No Unit)	Switching Operation (No Unit)	Measured Fault Current		Predicted Fault Current		% Difference		Maximum Voltage (kV)	Minimum Voltage (kV)	Voltage fluctuation (%)
		Peak @ 10ms (kA)	RMS @ 90ms (kA)	Peak @ 10ms (kA)	RMS @ 90ms (kA)	Peak @ 10ms (kA)	RMS @ 90ms (kA)			
30	With 200A load connected	13.83	5.10	13.37	4.87	3.33%	4.46%	6.417	6.353	1.00%
30	Without 200A load connected	13.83	5.10	13.50	5.24	2.37%	-2.70%	6.447	6.384	0.98%
13.3	With 200A load connected	12.88	5.09	13.27	4.95	-2.99%	2.79%	6.289	6.193	1.53%
13.3	Without 200A load connected	12.88	5.09	13.38	5.03	-3.88%	1.32%	6.453	6.298	2.40%
23	With 200A load connected	31.34	13.10	30.40	13.50	3.01%	-3.38%	6.298	6.150	2.35%
23	Without 200A load connected	31.34	13.10	31.02	12.87	1.01%	1.74%	6.451	6.273	2.76%

Table 1: Fault level prediction results and voltage fluctuation readings

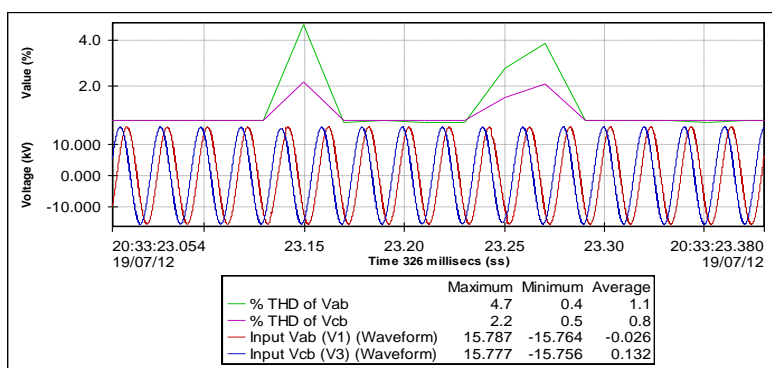

Figure 2: Total harmonic distortion of the wave form

High precision VTs and CTs allow the PM7000 to monitor voltage and current waveforms with a high degree of accuracy. The fully supported PM7000 hardware platform provides powerful processing capability, allowing the three-phase fault contribution to be monitored. The IntelliRupter provides the PM7000 Fault Level Monitor with controlled, non-customer-affecting, disturbances that overcome the sole reliance on naturally occurring system disturbances. For the worst case voltage fluctuation and assuming background flicker levels to be 50% of the network limit (typical of the real network environment), the acceptable repetition rate of controlled disturbances is 360 seconds. The THD values presented in Figure 2 are instantaneous values. When considered over a ten-minute period (as prescribed in G5/4-1) the averaged effect on THD would be negligible.

CONCLUSION

The laboratory tests have demonstrated that the IntelliRupter and PM7000 devices can be successfully combined and used to provide a fault level prediction within 4.5% of the measured fault level for the test cases considered. Using control functionality of the IntelliRupter to provide a disturbance, there is the possibility of predicting the fault level in real-time without causing any customer disturbance.

Since there is limited capability, at present, to monitor fault levels in 11kV electricity networks, and the maximum acceptable measurement error is considered to be $\pm 5\%$ of the actual fault level value, the results are considered to be highly encouraging.

The next steps in the project are to characterise the network and to use a novel integration process to monitor fault levels in an 11kV urban substation in the UK. This will form the technical basis of commercial contracts that will allow distribution system fault levels to be managed in real-time through switching operations and the connection / disconnection of additional generation.

ACKNOWLEDGMENTS

The authors would like to thank the following for their help during the fault level monitoring system tests: Supporting staff at Western Power Distribution; Martin Snell and David Hawkins at Parsons Brinckerhoff; Chris Bevan, Jim Niemira, Terry Bellei and the staff at the S&C Advanced Technology Center, Chicago, Illinois, USA.

REFERENCES

- [1] A. Collinson, F. Dai, A. Beddoes and J. Crabtree, 2003, *Solutions for the connection and operation of distributed generation*, Crown, London, UK.
- [2] Ofgem, 2012, *Low Carbon Networks Fund Governance Document (Version 5)*, Ofgem, London, UK.
- [3] Western Power Distribution, 2012, *Implementation of an active fault level management scheme (First Tier Pro-forma)*, Ofgem, London, UK.
- [4] G. E. Williamson, N. Jenkins, G. C. Cornfield, 1996, "Use of naturally occurring system disturbances to estimate the fault current contribution of induction motors", *IEE Proc.-Gener. Transm. Distrib.* Vol 143, No. 3, 243 – 248.
- [5] Department of Energy and Climate Change, 2011, *Carbon Plan: Delivering our low carbon future*, Crown, London, UK.
- [6] KEMA Ltd, 2005, *The contribution to distribution network fault levels from the connection of distributed generation*, Crown, London, UK.
- [7] Energy Networks Association, 1992, *Engineering Recommendation G74: Procedure to meet the requirements on IEC 909 for the calculation of short circuit currents*, ENA, London, UK.
- [8] G. C. Cornfield, 1993, "Estimating system fault level from naturally occurring disturbances", *Proceedings IEE Colloquium on Instrumentation in the Electrical Supply Industry*, 13/1 – 13/4
- [9] International Electrotechnical Commission, 2000, *IEC TR 60909-4: Examples for the calculation of short circuit currents*, IEC, Geneva, Switzerland.
- [10] S. Conner and A. J. Cruden, 2012, "Development of an Algorithm utilising a Digital Signal Controller to accurately determine in near "Real-Time" the Fault Level in DG", *Proceedings 47th International Universities' Power Engineering Conference*.
- [11] K. O. H. Pedersen, A. H. Nielsen and N. K. Poulsen, 2003, "Short-circuit impedance measurement", *IEE Proc.-Gener. Transm. Distrib.*, vol. 150, no.2, 169-174.
- [12] S. Yang and F. Yang, 2009, "Algorithm Development for Electricity Supply Fault Level Monitor Applied in Distribution Generation", *Proceedings International Conference on Electrical Engineering*, 1-6.
- [13] Scottish Power, 2011, *IFI Report 2010/11*, Scottish Power, Glasgow, Scotland.
- [14] E. S. Ibrahim, 2004, "Experimental Measurements of Fault Level For Sceco West, Kingdom of Saudi Arabia", *JKAU: Eng. Sci.*, vol.15, no.1, 83-102.
- [15] EPRI, 2010, *Patent Application 20100085065: Passive Agent System Impedance Monitoring Station and Method*, US Patent and Trademark Office.
- [16] Energy Networks Association, 1989, *Engineering Recommendation P28: Planning limits for voltage fluctuations*, ENA, London, UK.
- [17] Energy Networks Association, 2005, *Engineering Recommendation G5/4-1: Planning levels for harmonic voltage distortion and the connection of non-linear equipment to transmission systems and distribution network in the UK*, ENA, London, UK.