

## Company Directive

### STANDARD TECHNIQUE: SD7F/2

## Determination of Short Circuit Duty for Switchgear on the WPD Distribution System

#### Policy Summary

This document provides guidance on calculation of fault levels so as to determine the short-circuit duty for switchgear installed on the WPD distribution networks.

**Author:** Jonathan Berry / Peter Aston

**Implementation Date:** May 2017

**Approved by:**



Policy Manager

**Date:**

12 May 2017

**NOTE:** The current version of this document is stored in the WPD Corporate Information Database. Any other copy in electronic or printed format may be out of date. Copyright © 2017 Western Power Distribution

## **IMPLEMENTATION PLAN**

### **Introduction**

This ST provides guidance on calculation of fault levels so as to determine the short-circuit duty for switchgear installed on the WPD distribution networks.

### **Main Changes**

Updates to provide detail on the required methodology to model generator connections to the network.

### **Impact of Changes**

None.

### **Implementation Actions**

Primary System Design Team Managers to ensure all staff are briefed on the document updates.

### **Implementation Timetable**

This revised document may be implemented immediately.

## Revision Log

<b>Document Revision &amp; Review Table</b>		
<b>Date</b>	<b>Comments</b>	<b>Author</b>
May 2017	<ul style="list-style-type: none"><li>• Updated to include Appendix A and C</li><li>• All Appendices beyond A re-named as required</li><li>• Section 3.1 updated to provide Power System Tools to be used</li><li>• Section 3.2 included to provide specific generation modelling detail</li><li>• Section 3.3 added to provide impedance data</li><li>• Section 4.3 updated to provide voltage level specific break times</li></ul>	S. Hennell
April 2015	<ul style="list-style-type: none"><li>• Re-branded to WPD format</li><li>• Addition of Implementation Plan and Revision Log</li><li>• Updated to reflect organizational change</li><li>• References updates</li><li>• Removal of Appendices A &amp; B</li><li>• Appendix C re-named as Appendix A</li></ul>	S. Hennell

## CONTENTS

1.0	INTRODUCTION .....	5
2.0	RATINGS.....	6
3.0	MODELLING .....	7
4.0	METHOD .....	10
5.0	SOLUTIONS .....	11

## 1.0 INTRODUCTION

- 1.1 Calculation of fault levels should be carried out in accordance with the Energy Networks Association Engineering Recommendation G74 "Procedure to Meet the Requirements of IEC909 for the Calculation of Short-Circuit Currents in Three-Phase AC Power systems".
- 1.2 G74 uses a pre-fault voltage profile to calculate transformer tapping positions and induction motor in-feeds to represent the contribution from load to a fault.
- 1.3 Whenever significant changes to the network occur or load/generation increases significantly, it is necessary to calculate the maximum fault duty on system switchgear. If this value exceeds the switchgear rating, it may become damaged or rupture causing danger to life and extensive damage to plant.
- 1.4 As the calculated values are relied upon for safety issues, a safety margin should be allowed because of the following assumptions:
- (i) The load, hence induction motor infeed, is for average cold spell conditions and does not represent the worst case condition;
  - (ii) The transformers may be at a slightly lower tap with lower impedance;
  - (iii) The values used for line lengths and impedance values may contain small discrepancies;
  - (iv) A fault level and load-flow package looks for a converging solution and some allowance for errors is necessary; and
  - (v) The equivalent provided by NGC will be calculated with similar assumptions to those in (i) to (iv).

Once calculations indicate switchgear is above 95% of its rating it should be considered overstressed, unless detailed studies can show otherwise to a value no greater than 98% at the discretion of the Primary System Design Team Manager.

The errors inherent in any methodology and software program used, together with variance in data accuracy and assumptions, should be taken into account when undertaking any specific detailed studies where initial analysis indicates switchgear above 95% of its rating.

- 1.5 A WPD approved fault level modelling program shall be used for calculating fault levels down to and including the 11kV (or 6.6kV) primary busbars.
- 1.6 Actions required for confirmed problems are detailed in paragraph 5.3.

## 2.0 RATINGS

- 2.1 Switchgear fault ratings employed shall be as nameplate rating, or as advised by a Plant Engineer within the WPD Policy Team.
- 2.2 A given piece of switchgear, used at a different voltage level, will have a different short circuit rating in MVA eg 250MVA 11kV gear only has a rating of 150MVA at 6.6kV. To avoid confusion arising from assumptions about nominal voltage, kA ratings shall normally be used in studies. Nameplates can quote either kA or MVA depending on age.
- 2.3 Switchgear can have enhancements to its fault current rating at different voltage levels. These are rare but will be found on the nameplate.

NOTE: Ratings for equipment on 6.6kV networks should be checked carefully as the different voltage ratings have caused confusion in the past.

- 2.4 A 2.55 multiplier is applied to the switchgear break rating (page 18 clause 9a BS116 (1952)) when make duties are calculated for circuit breakers purchased before 1988.
- 2.5 For switchgear purchased from 1988 onwards this multiplier is 2.5 (page 118 clause 8.103.4 BS5311 (1996); now BSEN62271-100 clause 4.103).
- 2.6 New switchgear is quoted with a break rating in kA, for example 13.1kA. The make rating is therefore:

$$2.5 \times 13.1 = 32.75 \text{ kA}$$

If the circuit breaker will see 34kA fault current for making onto a fault, it is overstressed. Confusion could arise if quoting a value of 34kA on 13.1kA gear. In this case it would be good practice to state that the switchgear is at 104% of its make rating.

- 2.7 On the 132kV network single phase fault levels can be significantly higher than 3 phase fault levels depending where the fault is. Single phase switchgear ratings can be higher than three phase ratings. Where nameplates do not provide single phase fault rating information, or in event of a query then please seek guidance from a Plant Engineer within the WPD Policy Team.
- 2.8 Where the X/R ratio is less than 3.3 then a safety factor of 1.15 as specified in G74 5.4.4 (referring to IEC 909 clauses 9.1.3.2 and 9.2.1.2) must be applied to the peak short circuit current. For 132kV sites where the X/R ratio is high (>14), the DC component of the short circuit current becomes significant and there are differences between ratings of equipment specified to BSEN62271-100 and that to current version of WPD EESPEC 7 (ENATS 41-37). For guidance on this refer to Policy Team (see also BSEN62271-100 in comparison with EESPEC 7).

## 3.0 MODELLING

### 3.1 General

3.1.1 This detail is provided for the use on the following two Power System Analysis Tools:

IPSA: Version 1.6.X; and  
PSS/E: Version 32.X.

3.1.2 Load is partly made up of induction motors. They can act as generators when the supply is disconnected. The motors continue to rotate due to inertia and this generates a fault infeed back into the system. Motors will thus contribute to the sub-transient (make) fault studies. For three phase faults this fault contribution drops to an insignificant value after 120ms and so can be ignored for normal transient (break) studies (G74 clause 9.5.2). For single phase faults, induction motors continue to contribute to the fault beyond 120ms, requiring the infeed to be modelled.

3.1.3 Values for induction motor infeed used are indicative allowances as specified in G74. They should be used unless a measured value of the infeed is known.

3.1.4 It is important to model transformers correctly as the transformer connection can act as a zero phase sequence (ZPS) path. Simply connecting a transformer with an open point on the far side can increase single phase fault levels. A star-delta transformer offers no ZPS path through itself, so when a generator is connected through a star-delta transformer its ZPS source impedance is not relevant for fault studies on WPD's system. However if the star point is within WPD's network or an earthing transformer is used the single phase fault levels will increase. If tertiary windings are added to transformers then these will also have an impact on the single phase fault level.

3.1.5 Fault infeeds are calculated for day loads as it is assumed that peak night loads will be mainly resistive heating. If it is known that this is not the case, then it may be necessary to use night loads or model the inductive loads separately.

3.1.6 Three phase fault levels are generally higher than single phase fault levels for the 33kV and 11kV network. This is due to the impedance earthing used at these levels. This may not be the case for old power station sites where non-standard arrangements are used or where impedance earthing is not used (5 MVA transformers).

3.1.7 It may be necessary to use a model of the National Grid Company (NGC) network as a source. Due to the interconnectivity of WPD's 132kV network, it is necessary to model part of their 400kV system. This gives a more realistic model and pushes the equivalent further away from our network. It is necessary to use the same assumptions that are used when NGC calculate the equivalent, (voltages etc.) in order to achieve accurate results.

## 3.2 Generation

3.2.1 The transient and sub-transient models of the generators should be constructed using the corresponding reactance and time-constants of the generators. In the absence of manufacturer data, Table 1 can be used for typical parameters of different generators. Converter based generator may have similar behavior (fault infeed) during sub-transient and transient periods. The control system of the converter may not allow the current to exceed the rating of semiconductors i.e. converter rating. So in case of a fault, converter contributes up to its rating (or short-term rating) depending on the pre-defined settings of the control.

3.2.2 The values provided in Table 1 are to be used only in the absence of generator specific data at the point of initial offer, if no other detail is practicably available. The generator model must be revised with full, specific, generator detail prior to energisation.

3.2.3 When modelling a generator to provide a connection offer all network elements of the customer's network between the point of common coupling and the generator connection location, such as transformer and cable, shall be included. This information should be provided, by the customer, in the form of a complete impedance model.

*Table 1 – Typical parameters of the generators*

<b>Synchronous generators (11kV)</b>					
	2 – 5MVA	5 – 20 MVA	20 – 60 MVA		
Armature Resistance [p.u]	0.0068	0.0075	0.0075		
Synchronous reactance [p.u]	1.8	2.0	2.0		
Transient reactance [p.u]	0.19	0.19	0.19		
Sub-transient reactance [p.u]	0.13	0.13	0.13		
Open circuit transient time	3	6	10		
Open circuit sub-transient time	0.04	0.06	0.07		
<b>Synchronous generators (0.415kV)</b>					
	100 kVA	500 kVA	1 MVA	1.5 MVA	2 MVA
Armature Resistance [p.u]	0.0077	0.0095	0.0095	0.0093	0.0074
Synchronous reactance [p.u]	2.05	2.53	2.54	2.49	1.96
Transient reactance [p.u]	0.17	0.13	0.20	0.21	0.16
Sub-transient reactance [p.u]	0.12	0.09	0.14	0.15	0.12
Open circuit transient time	0.34	1.56	2.35	3.56	4.04
Open circuit sub-transient time	0.014	0.017	0.036	0.042	0.04
<b>Converter connected generators</b>					
	Make Time Fault infeed [p.u]		Break Time Fault infeed [p.u]		
Battery Storage	3.0		1.2		
PV System	3.0		1.2		
Micro CHP	3.0		1.2		
Wind Turbine / DFIGs	4.0		2.0		



### 3.2.4 Converter Connected Generator Modelling Specification

The X/R ratio for converter connected generators shall be 10.

When producing the model a Grid Infeed equivalent may be used which enables a direct Make and Break fault infeed contribution to be specified as well as a prescriptive X/R ratio. If this is not available the process as described below shall be used.

A converter connected generator can be modelled with an equivalent synchronous generator where transient and sub-transient impedances are calculated based on the fault infeed. For example, a PV system with generation capacity of 100kVA and 1.2 p.u. fault infeed can be modelled as a synchronous generator with transient and sub-transient impedance of 0.83 p.u. ( $=1/1.2$  p.u) where  $S_{base}=100kVA$ . Make and Break scenarios shall be considered separately in this instance.

### 3.3 Impedance Data

3.3.1 In order to suitably model any generation's fault level contribution connected to the network accurately the impedance between the PCC and the generation must be considered.

3.3.2 Where specific data is unavailable an estimate of the distance between the PCC and the generator location must be made and the appropriate overhead line or cable impedance be modelled as per types described in ST: SD8A and ST: SD8B.

3.3.3 In the absence of specific customer data each generator shall be modelled with an accompanying transformer as shown in Figure 1. The R and X data shall be a multiplication of the generators MW rating from data provided in Table 2.

*Figure 1 - Generator and Transformer Arrangement*

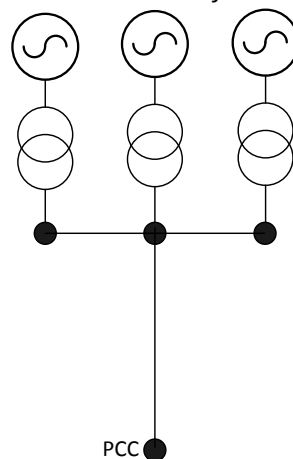

Table 2 - Transformer Detail

Generator Type	R Factor	X Factor
LV Connecting to 11kV	0.67	3.38
LV Connecting to 33kV (<5MVA)	0.13	1.55
LV Connecting to 33kV (>5MVA)	0.0019	0.0131
HV Connecting to 33/66/132kV	0.00045	0.01158

Example: 20MW Generator generating at 415v and connecting to the 33kV network:

$$\text{Transformer impedance} \quad R = 20 * 0.0019 = 0.038; \text{ and}$$

$$X = 20 * 0.0131 = 0.262.$$

3.3.4 Prior to the energisation of a generator the actual transformer and cable details must be modelled. The customer shall provide this detail as per the detail prescribed in Appendix C. This is expected to be accompanied by a customer equipment single line diagram.

#### 4.0 METHOD

4.1 Worst case faults should be considered. That is a zero impedance fault (three phase and single phase-earth) on the outgoing side of a circuit breaker. All appropriate generators/induction motor loads should be modelled, producing their maximum infeed.

4.2 A sub-transient study (within 1 cycle i.e. 0-20ms) is required for making onto a fault. A transient study (20-120ms) is required for breaking a fault.

4.3 Sub-transient studies are calculated for 10ms. The transient study should be based on the time it takes for the breaker to begin operation. Where possible, the actual protection response time should be considered for transient studies i.e. Breaking short circuit calculations. In the absence of this information Table 3 can be used for the breaking time at different voltage levels.

Table 3- Breaking time at different voltage levels

Voltage Level (kV)	Breaking time (ms)
11kV	70
33kV	70
66kV	50
132kV	50

4.4 The system should be fully intact unless an outage would mean a more onerous running arrangement e.g. 4 transformers split into two bars, closed up for the outage of one transformer.

- 4.5 Fault levels on the 132kV and 33kV network shall use 1MVA of fault infeed per MVA of LV connected load. This is as stated in G74. If the LV load is lumped together on the 11kV bars then it is necessary to account for the impedance of the primary transformers, in order to provide the required 1MVA of fault infeed at the 33kV busbars. For a conservative figure 1.1MVA infeed per MVA of LV load can be used. The actual value will need to be calculated for marginal fault levels (See Appendix B).
- 4.6 For load connected at 11kV and above (i.e. HV connected customers) an infeed value of 2.6MVA per MVA of load should be used.
- 4.7 If X/R ratios are to be calculated, it is necessary to use a uniform voltage profile (flat conditions) as stated in G74 Recommendations (Engineering Technical Report No 120 clause 6.3.11).

## **5.0 SOLUTIONS**

- 5.1 When calculating fault levels it is important to consider which switchgear has a potential problem. A high fault level on a primary substation bar may indicate potential overstressing on associated secondary distribution switchgear (switches, downstream circuit breakers etc.)
- 5.2 The fault level on a busbar may be higher than the rating of some of its circuit breakers. If those circuit breakers are facing towards a source (e.g. transformer circuit breakers) their fault duty is likely to be significantly lower than that seen at the busbar (Appendix B has an example of this). This means that the fault current through each breaker needs to be considered.
- 5.3 When problems are found and confirmed, Control and the relevant Distribution Manager shall be informed.

Control will determine the immediate action to be pursued and will need to know the circuit breakers involved, the level of stressing, and if possible a proposed switching solution to remove the fault level problem.

Subsequent checking of equipment fault level ratings will be undertaken by System Design in conjunction with Policy team. If equipment replacement is necessary to overcome the overstressing problem, then for 132kV or 33/11kV, 33/6.6kV substations the Primary System Design Manager will produce a solution. For secondary switchgear on the 11kV (or 6.6kV) network, solutions will lie with the local Distribution Manager.

- 5.4 Marginal problems should, if possible, be tested with a summer model of the NGC equivalent in order to confirm that they are within limits for summer conditions. This could allow abnormal arrangements (closing up split busbars) for the maintenance period giving Control more flexibility.

**TERMINOLOGY**

**Making Fault Current:** This is the short circuit current that a circuit breaker shall be capable of closing onto if it is used to energise a faulted network. Making fault current is the maximum possible instantaneous asymmetric fault current which comprises the DC component and symmetric AC component of fault current. The first peak of fault current occurs at around 10ms after fault occurs.

**RMS Breaking Fault Current:** This is the RMS value of the AC component of the short circuit current at separation time of circuit breaker contacts (Breaking time). This value does not include the DC component of the fault.

**DC component of fault current:** The initial value of the DC component of the fault depends on the point of voltage waveform at which fault occurs and it decays based on the X/R ratio.

**X/R:** This is the ratio of the reactance to resistance of network between the point of fault and source(s) of fault currents. The DC component of the fault decays exponentially and as a function of X/R ratio. DC component decays slower where the X/R ratio is higher.

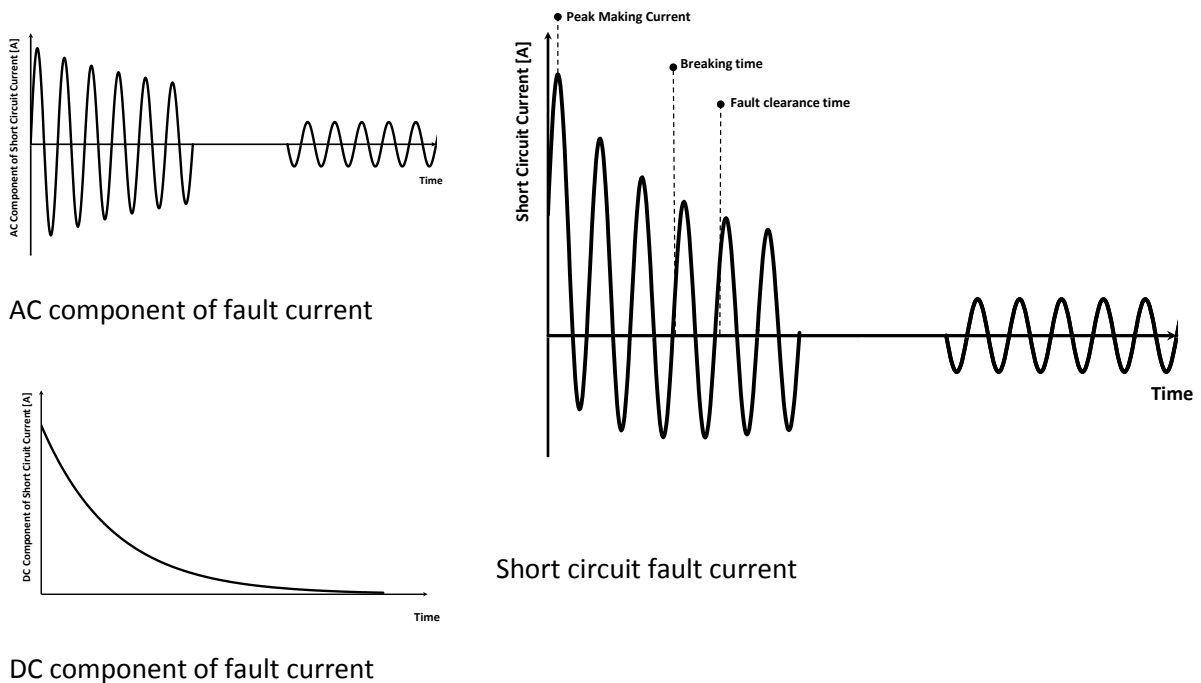

**FAULT DUTIES - EXAMPLE**

The fault duty of a circuit breaker is the current seen by the circuit breaker for a zero impedance fault at its terminals (the side used is that which will give the highest through current).

When considering the fault duty on switchgear it is not appropriate simply to look at the fault level on the bar. This can be seen in the following example.

Figure 2 shows a simple network. A fault level on the 33kV bar is calculated as 17.5kA. The two transformer circuit breakers have a rating of 13.1kA. The fault duty on each of the circuit breakers is  $17.5 - 8.75 = 8.75\text{kA}$ . This is well within their rating.

In general, for a busbar with circuit breakers having the same rating, those facing a source will be the least stressed.

*Figure 2 - Illustration of Fault Level and Fault Duty*

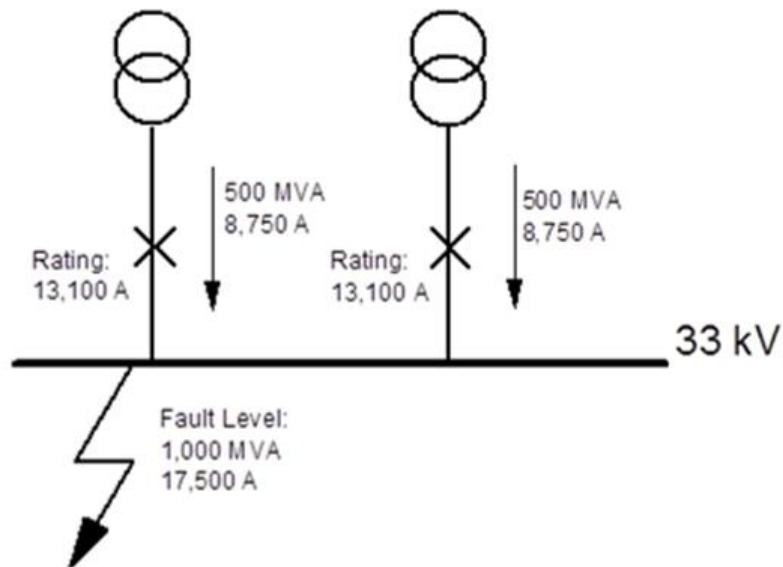

## APPENDIX C

### CUSTOMER DETAIL PROVISION TEMPLATE

<\\AVODCS01\DMS\MA\SD\SD007\SD007F\WPD Customer Detail Provision Template.xlsx>

## APPENDIX D

### SUPERSEDED DOCUMENTATION

This document supersedes ST:SD7F/1 dated April 2015 which has now been withdrawn.

## APPENDIX E

### ASSOCIATED DOCUMENTATION

G74 (1992) "Procedure to meet the requirements of IEC 909 for the Calculation of Short-Circuit Currents in Three-Phase AC Power Systems"

Engineering Technical Report 120 – "Application Guide for G74"

BSEN60909 "Short circuit currents in three-phase ac systems"

BS116 "Oil circuit breakers (1952)"

BSEN62271-100 "Switchgear and Control – Alternating current circuit breakers"

EESPEC 7 "Switchgear for use on 66kV and 132kV systems"

## APPENDIX F

### IMPACT ON COMPANY

This policy is relevant to staff who deal with fault levels and switchgear ratings. This includes System Design, Control and the Policy Team.

## APPENDIX G

### KEY WORDS

Switchgear, overstressing, fault level, generator connection, induction motor, sub-transient, transient.