

Company Directive

ENGINEERING SPECIFICATION

EE SPEC : 170

145kV Outdoor Dead Tank Circuit Breakers

Summary:

This document specifies the requirements for 145kV outdoor dead tank circuit breakers

Author: Stephen Hennell / Anthony Smith

Implementation Date: September 2020

Approved by



Carl Ketley-Lowe
Engineering Policy Manager

Date: 21st September 2020

Target Staff Group	Anyone involved with the addition, or alteration of, 132kV substations inclusive of but not limited to Planners, Project Engineers, Technicians, EDS, PSD and Purchasing
Impact of Change	Green – No impact on current working practices
Planned Assurance checks	Nil

All references to Western Power Distribution or WPD must be read as National Grid Electricity Distribution or NGED

NOTE: The current version of this document is stored in the NGED Corporate Information Database. Any other copy in electronic or printed format may be out of date. Copyright © 2022 National Grid Electricity Distribution

IMPLEMENTATION PLAN

Introduction

This document specifies the requirements for 145kV outdoor dead tank circuit breakers for use on the Western Power Distribution (WPD) 132kV network.

Main Changes

This is a new document replacing the parts of EESPEC 7 covering 145kV dead tank circuit breakers. Separate EESPEC documents cover the WDP requirements for 145kV live tank circuit breakers.

This document includes requirements for the potential reduction or elimination of SF6 from 145kV dead tank circuit breakers by the use of alternative technology or gas.

Impact of Changes

EESPEC 7 shall no longer apply to 145kV dead tank circuit breakers supplied for use on the WPD 132kV network.

Any new contract will be based on this updated specification.

This specification is not retrospective for current contracts.

Implementation Actions

This new EESPEC has been issued to allow the tender of replacement contracts for 145kV dead tank circuit breakers.

Procurement Team to use this specification for future Tenders.

Implementation Timetable

EESPEC 170 will be used as part of the 2020 tender process for 145kV live tank and dead tank circuit breakers.

ICPs will be expected to comply with this new specification within 6 months of its issue.

Items currently on order/under an active quotation by an ICP, to the existing specification shall continue to be acceptable to WPD but new orders, after the 6 months have elapsed will need to comply with this specification.

Exception to this may be made by WPD DNO Policy team upon formal request.

REVISION HISTORY

Document Revision & Review Table		
Date	Comments	Author
September 2020	<p>This is a new document replacing sections within EESPEC 7 relating to 145kV dead tank circuit breakers.</p> <p>Significant changes incorporated from EESPEC 7 are:</p> <ul style="list-style-type: none"> • Requirement for low or no GWP by the replacement of SF6 gas within the circuit breaker by an alternative technology or gas. • Updating of standards references. • Make, type, sizes and colours of gas filling points specified to allow for different gas or gas mixtures. • Requirement for temporary warning notice to deter against operation of the circuit breaker prior to completion of gas fill. • Requirement for permanent notice warning against the operation of the circuit breaker when the gas pressure is below the Minimum Functional Pressure. • Pole referencing and layout clarified for consistency. • Requirement for composite DC schematic diagram. • Creepage distances given as unified specific creepage distance (USCD). 	Stephen Hennell / Anthony Smith

CONTENTS

1.0	INTRODUCTION	5
2.0	REQUIREMENTS	5
3.0	MODIFICATIONS AND ADDITIONS TO ENA TS 41-37	6
4.0	SPECIFIC REQUIREMENTS.....	7
5.0	RATINGS	9
6.0	MECHANISM	11
7.0	EARTHING.....	11
8.0	AUXILIARY EQUIPMENT & SECONDARY WIRING	12
9.0	INTERLOCKING DEVICES AND PADLOCKING FACILITIES	14
10.0	PRIMARY CONNECTIONS AND MARKINGS	15
11.0	CLEARANCES FOR OVERHEAD CONDUCTOR CONNECTED EQUIPMENT	16
12.0	GAS SYSTEM	16
13.0	RATING PLATES	18
14.0	CURRENT TRANSFORMERS	18
15.0	INSTALLATION AND COMMISSIONING TESTS	21
16.0	DRAWINGS	22
17.0	TEST RESULTS	22
18.0	DOCUMENTATION TO BE PROVIDED AT TIME OF TENDER	22
19.0	TYPE TESTS	23
20.0	ROUTINE TESTS	23
	APPENDIX A	24
	APPENDIX B	25
	APPENDIX C	26
	APPENDIX D	26
	APPENDIX E	26
	APPENDIX F	26
	APPENDIX G	26
	APPENDIX H.....	26
	SCHEDULE A – WPD REQUIREMENTS FOR 145kV DEAD TANK CIRCUIT BREAKER	27
	SCHEDULE B – MANUFACTURER DECLARATION FOR 145kV DEAD TANK CIRCUIT BREAKER.....	28
	SCHEDULE C – CURRENT TRANSFORMER REQUIREMENTS	29
	SCHEDULE X - SCOPE AND RESPONSIBILITIES FOR SITE WORKS	33

1.0 INTRODUCTION

1.1 This Technical Specification sets out Western Power Distribution (WPD) requirements for 145kV outdoor dead tank circuit breakers for use on its 132kV networks.

1.2 It is based on and must be read in conjunction with the current version of ENA TS 41-37 and other referenced Standards and specifications listed either within ENA TS 41-37 or this WPD specification. WPD options, changes or additions to the ENATS requirements are stated in this WPD document. Unless otherwise stated the requirements of the relevant part(s) of ENATS 41-37 shall apply.

1.3 Any selection of options or changes to this specification shall be made by WPD in writing.

1.4 Where this WPD Technical Specification is being used for Tender purposes then unless otherwise specified in writing at time of Tender, all equipment offered against this Technical Specification shall be compliant with this Technical Specification.

1.5 WPD has a distinct preference for equipment which holds an Energy Networks Association (ENA) Notice of Conformity (NoC) to the current version or a previous version of an ENA Technical Specification (TS). Where equipment does not have an ENA NoC then the following preferences apply in order:-

- Equipment from a design where other ratings have an ENA NoC;
- Equipment manufactured in a facility where other equipment having an ENA NoC is manufactured;
- Other non ENA Assessed equipment.

Where equipment offered does not have an ENA NoC then the manufacturer will be required to provide WPD with details and test data for review that will be equivalent to completing an ENA NoC Assessment. There is no guarantee that following WPD assessment of the equipment that it will be accepted for use by WPD.

2.0 REQUIREMENTS

2.1 General

2.1.1 Suppliers and Manufacturers shall satisfy the requirements of BS EN ISO 9000 and BS EN ISO 9001 for all products supplied.

2.1.2 All equipment and systems shall satisfy requirements of the EMC directive. EMC emissions and immunity requirements shall, as a minimum, satisfy the requirements of the generic emission and immunity standards for industrial environments BSEN 61000-6-2 and BSEN 61000-6-4 and also all relevant EMC product standards.

2.1.3 Accepting that this is an early period with the technology and availability of products in an initial phase of market readiness, WPD is looking to move to purchasing equipment that has a Global Warming Potential (GWP) of 1 or less, however equipment utilizing SF6 may be offered in the event that manufacturer cannot offer a low GWP unit. Where both are available then the supplier shall offer both as an option to WPD.

2.1.4 Where equipment is provided with ratings that exceed those in the enquiry/order then these higher values shall be those applied to the equipment rating plates.

2.2 Guarantee

2.2.1 The supplier of the plant / equipment covered by this specification shall provide a guarantee for that equipment. The guarantee period that the supplier warrants will be a minimum of 60 months (five years) from the date of completion of cold commissioning on site of the relevant plant / equipment; or where equipment has been manufactured but not delivered to WPD but placed into storage at WPD request, or delivered to WPD but not cold commissioned within 6 months, then the warranty period shall be 66 months from the date of storage or delivery.

2.2.2 Note, this requirement applies to plant / equipment purchased by Independent Connection Providers (to be adopted by WPD) as well as equipment purchased directly by WPD.

2.3 Safety Labels

Safety labels, warning signs and notices shall be compliant with UK standards in terms of colours, pictograms and layout. [BS5499]

3.0 MODIFICATIONS AND ADDITIONS TO ENA TS 41-37

3.1 References

3.1.1 References are in accordance with ENA TS 41-37 with the following additions in Table 1, below.

3.1.2 Users of all standards and technical specifications shall ensure they are applying the most recent editions together with any amendments.

3.1.3 Whilst the IEC base document is listed for information, the prime document that shall take priority is the British Standard enacting the European Standard (EN) or European Harmonisation Document (HD).

BS No.	Title	IEC / ISO base
BSHD 60269	Cartridge fuses for voltages up to and including 1000V ac and 1500V dc	IEC 60269
BSEN 60898	Circuit breakers for overcurrent protection for household and similar installations	IEC 60898
ENA TS 48-4	DC Relays Associated with a Tripping Function in Protection Systems	
ENA TS 48-5	Environmental Test Requirements for Protection and Control Equipment and Systems	

Table 1 Additional References

4.0 SPECIFIC REQUIREMENTS

4.1 System earthing (BSEN 62271-1 – clause 9.1)

The equipment shall be suitable for use on three phase systems at 132kV in which the neutral is solidly earthed.

4.2 Normal Service Conditions

4.2.1 WPD require switchgear to be suitable for outdoor use with an ambient air temperature in the range -25°C to +40°C outdoor. [ENATS 41-37 Part 1 - 2.1.2]

4.2.2 The altitude does not exceed 1000m.

4.2.3 Other service conditions shall be as BSEN 61869-1 clause 4.2.5:-

- the average value of the ambient air temperature, measured over a period of 24 h, does not exceed 35 °C;
- solar radiation up to a level of 1 000 W/m² (on a clear day at noon) should be considered;
- the ambient air may be polluted by dust, smoke, corrosive gases, vapours or salt. The pollution does not exceed the pollution levels given in IEC 60815;
- the wind pressure does not exceed 700 Pa (corresponding to a 34 m/s wind speed);
- the presence of condensation or precipitation should be taken into account;
- the ice coating does not exceed 10 mm.

4.3 Requirements for the external insulation

4.3.1 WPD requires insulators for Site Pollution Severity Class e (IEC/TR 60815:1986) or Class IV (IEC/TR 60815:1986).

4.3.2 Insulators having an alternating shed profile are preferred.

4.3.3 The creepage distances shall be as given in Table 3 below:-

Site Pollution Severity Class	Minimum mm/kV	Ratio = creepage distance divided by arcing distance
IEC/TS 60815:2008 e	Unified specific creepage distance 53.7	≤4.0
IEC/TR 60815:1986 IV Very Heavy	Specific creepage distance 31	

Table 3 Creepage distances [IEC/TR60815 & IEC/TS60815]

- 4.3.4 Tenderers shall state what shed profile is being offered and which Site Pollution Severity Class is being offered where this is not in accordance with 4.3.1 and 4.3.2 above.
- 4.3.5 Bushing insulators may be porcelain or composite. Porcelain insulators shall be coloured brown however by WPD agreement grey may be offered where this provides a cost advantage or reduced delivery timescales.
- 4.4 Corrosion protection
 - 4.4.1 All exposed hardware shall be stainless steel.
 - 4.4.2 Any aluminium castings shall be anodized.
 - 4.4.3 WPD prefer fabrication from stainless steel for auxiliary enclosures.
 - 4.4.4 Other exposed non-aluminium or non-stainless steel metal parts shall be shot blasted and spray galvanized. This shall be followed by two coats of zinc rich primer and two coats of polyurethane based paint. The preferred paint colour is Dark Admiralty Grey (BS381C 632), however other colours may be acceptable (eg RAL 7033).
- 4.5 Auxiliary enclosures
 - 4.5.1 The degree of protection for low-voltage and/or auxiliary enclosures shall be at least IP44 according to BSEN60529.
 - 4.5.2 Shall be fabricated of stainless steel and painted.
 - 4.5.3 Shall be provided with a securing and locking device that provides security against unauthorised access. The locking arrangement shall be robust and accommodate a padlock with 41mm square body and with a 4mm to 7mm diameter shackle having a clear inside width of 21mm and an inside length of 16mm to 45mm. The holes provided for the shackle shall not be less than 8mm diameter.
 - 4.5.4 Where an auxiliary enclosure (eg. terminal box) is fitted it shall be placed so that work can be carried out on this box with the equipment live after the equipment is installed and cables terminated.
 - 4.5.5 Auxiliary enclosures shall be suitable for the termination of armoured multicore cables using cable glands.
 - 4.5.6 Sufficient terminal blocks shall be provided to terminate all the cores of all multicore cables as detailed in the Summary of Technical Parameters for the circuit breaker.
 - 4.5.7 Auxiliary enclosures shall be accessible from ground level without the use of ladders or platforms.
 - 4.5.8 Auxiliary enclosures shall be fitted with adequate ventilation so as to prevent condensation when used in conjunction with an anti-condensation heater. Any ventilation shall be such that vermin and insects are prevented from entering the enclosure.

4.6 Flood resilience

4.6.1 To provide resilience against flooding all mechanisms and control equipment, including auxiliary cable glands and terminations shall be located as high as practicable above ground level and at a minimum height to base of enclosure of 500mm.

4.6.2 Tenderers shall provide outline general arrangements drawings showing the proposed location and height above ground level.

5.0 RATINGS

5.1 Rated Voltage (U_r)

The rated voltage shall be 145kV. [ENATS 41-37 Part 1 cl 4.1]

5.2 Rated insulation level

The rated insulation levels shall be as in the table below:

Rated voltage U_r kV (rms value)	Rated short-duration power-frequency withstand voltage U_d kV (rms value)		Rated lightning impulse withstand voltage U_p kV (peak value)	
	Common value	Across the isolating distance	Common value	Across the isolating distance
145	275	315	650	750

5.3 Rated Frequency (f_r)

The rated frequency shall be 50Hz.

5.4 Rated normal current (I_r)

The rated normal current shall be 2500A. [ENATS 41-37 Part 1 cl 4.4.1]

5.5 Rated short-time withstand current (I_k)

The rated short-time withstand current shall be a minimum of 31.5kA. [ENATS 41-37 Part 1 cl 4.4.1] (Note: the values of short-time rated current are the same for single-phase and three-phase.)

5.6 Rated duration of short circuit (t_k)

The value of rated short circuit current shall be 3 seconds.

5.7 Rated peak withstand current (I_p)

The rated peak withstand current shall be 2.7 times the rated short-time withstand current.

5.8 Rated short circuit breaking current (Isc)

The rated short-circuit breaking current shall be not less than the rated short-time withstand current as specified in 5.5 above i.e. 31.5kA.

5.9 Rated DC time constant

The rated value of short-circuit breaking current shall be assigned at a dc time constant of 120ms.

5.10 Rated short-circuit making current

The rated short-circuit making current shall be equal to 2.7 times the rms value of the ac component of the rated short-circuit breaking current in 5.8 above.

5.11 Rated operating sequence

Circuit breakers shall be suitable for rapid auto-reclosing.

The rated operating sequence shall be O – 0.3s – CO – 3min – CO.

5.12 Rated Supply Voltage of Closing and Opening Devices and of Auxiliary and Control Circuits (Ua)

Switchgear shall be capable of all normal operations without any effect affecting its rated performance, within the voltage ranges specified in table below:-

Nominal voltage V	Criteria for rated supply voltage operating range	Closing and opening releases and operating devices		Other operating devices
		Close volts V	Open volts V	Volts V
110	Maximum operating voltage (max. charging voltage)	137.5	137.5	137.5
	Minimum operating voltage	87.5 [80% of nominal voltage]	77 [70% of nominal voltage]	87.5

5.13 Rated supply frequency of closing and opening devices and of auxiliary circuits

The rated supply frequency shall be dc.

6.0 MECHANISM

6.1 Stored energy closing

Mechanisms using a motor-wound spring are preferred by WPD.

6.2 Three pole operation

Circuit breakers shall be arranged for three pole simultaneous operation. This shall be enabled by mechanical linkage and not by electronic or electrical means.

6.3 Local manual operation

Provision shall be made for mechanically operated local manual tripping and closing.

6.4 Slow closing device

Where facilities are provided then the necessary loose parts, handles, safety blocks etc shall be supplied (1 set per site).

6.5 Anti-pumping

In the event of a continuous close signal being maintained after a failure to latch in the closed position, or an opening operation immediately following a closing operation, and a continuous close signal being maintained, there shall not be repeated attempts to close the circuit breaker.

6.6 Operating systems interlocks

Operating systems shall be arranged to prevent a close operation if sufficient energy is not available to complete a normal Close/Open (CO) operation.

6.7 Trip circuit supervision

Circuit breaker tripping coils and their associated circuits shall be suitable for continuous supervision which is functional regardless of the state of the circuit breaker (open or closed).

6.8 Trip and close coil isolation

Isolation facilities shall be provided to the circuit breaker trip and close coils. These shall be labelled appropriately. These facilities shall be such that the open-circuit supervision system shall detect isolation of the opening coils.

6.9 Speed/Travel Transducer

Equipment offered shall either be fitted with a speed/travel transducer or the facility to permanently install one at a later date without major equipment modification or work affecting the circuit breaker operating mechanism.

7.0 EARTHING

7.1 Earthing conductors

Earthing conductors and connections to them, for outdoor switchgear, shall be provided in accordance with the requirements of BSEN 50522.

7.2 Earthing of compartments and enclosures

Facilities shall be provided to bond all compartments and enclosures to the main substation earth via the earthing conductor. The method of bonding shall be capable of withstanding the rated short-time current.

8.0 AUXILIARY EQUIPMENT & SECONDARY WIRING

8.1 Auxiliary switches

8.1.1 The tolerance in the drive train to auxiliary switches shall be such that the correct operation is maintained at extreme ends of tolerance.

8.1.2 In addition to auxiliary switches required for normal circuit breaker function, further auxiliary switches shall be provided for WPD use and all these, including any spares, shall be wired out to an accessible terminal block within the fixed portion. The minimum provided shall be:-

- 6 off normally open circuit breaker auxiliary switches
- 6 off normally closed circuit breaker auxiliary switches
- 2 off normally open springs charged auxiliary switches
- 2 off normally closed springs charged auxiliary switches

8.1.3 The circuit breaker shall be provided with a pair of normally open volt-free contacts that provide will indication in the event that the operating spring has failed to charge correctly.

The arrangement shall include a time delay to prevent spurious alarms during a normal spring charge cycle, as well as visual indication of the spring charge alarm state.

8.2 Secondary wiring identification

At the interface between switchgear and protection and control gear, wiring and ancillary electrical equipment shall be identified in accordance with ENATS 50-19.

8.3 Auxiliary Supplies

Circuit breaker spring winding motor and protection/alarm relay auxiliary supplies for new equipment are normally rated at 110Vdc.

8.4 Small Wiring and Terminals

Small wiring and terminals shall comply with ENA TS 41-37 with the following additions:

8.4.1 The application of small wiring, ancillary electrical equipment and protection shall in general follow the principles in Engineering Recommendation S15.

8.4.2 Secondary wiring shall comprise of:

8.4.3 AC wiring: 2.5mm² (minimum) copper stranded cable with PVC insulation to BS6231 Type BR, or equivalent tri-rated cable complying with BS6231.

- 8.4.4 DC wiring: 1.5mm² (minimum) copper stranded cable with PVC insulation to BS6231 Type BR, or equivalent tri-rated cable complying with BS6231.
- 8.4.5 Terminal blocks used for protection, alarm and control circuits shall be screw clamp with spring type, in accordance with EATS 50-18 Type B. Terminal blocks for 24VDC and 48VDC tele-control wiring, and for transducer output wiring shall be screw clamp type, to EATS 50-18 Type C with a hinged link for isolation purposes. Sufficient space shall be allowed so that connections can be tightened or un-tightened and wires removed and re-inserted. Spare cores shall be terminated at the terminal blocks furthest from the cable gland.
- 8.4.6 Test sockets shall be provided on the trip and close circuits in order to allow the ready connection of test leads when timing the circuit breaker during maintenance.

8.5 Fuses and Links

- 8.5.1 Secondary fuselinks, links and fuse carriers shall be in accordance with EATS 50-18 and BS HD 60269-2 reference A.
- 8.5.2 Fuses and fuse holders up to 20A rating shall be in accordance with BS HD 60269-2 reference A1.
- 8.5.3 The fuse holders and bases shall be coloured as follows:

- 2A, 4A, 6A, 10A fuselink ratings: black
- 16A fuselink rating: green
- Solid links: white

2A, 4A and 10A fuse holders and bases shall have supplementary markings applied to denote the fuse rating. These markings shall be applied using permanent self-adhesive coloured vinyl tapes as follows:

- 2A Purple
- 4A Blue
- 10A Grey

[See example photo right.]



- 8.5.4 GE Power Controls/Eaton Bussmann or Mersen Red Spot fuse holders shall be provided unless otherwise agreed at the time of tender.
- 8.5.5 All fuses and links shall be mounted vertically, grouped logically and consistently in the panel and shall be clearly labelled.

The label shall show the function of the fuses/links and include the fuse/link number as specified on the schematic drawings. The fuse rating shall also be included on the label.

Where a double row of fuses and links is required, the labelling of the bottom row may need to be mounted on a stand-off bracket to ensure they are clearly visible.

- 8.5.6 Fuse terminals shall be suitably shrouded to minimise electric shock hazards. The incoming (supply) side of each circuit shall be connected on the bottom terminal of the fuse/link.

8.6 Ancillary Equipment

Requirements for ancillary equipment including relays, contactors, control / selector switches, transducers, push buttons and lamps are specified in EESPEC:136.

8.7 Anti-Condensation Heaters

A heater shall be provided at an appropriate location in the mechanism box. The heaters shall be 230Vac. A control thermostat shall be provided. The supply to the heater/s shall be controlled by a double pole switch which shall be located at a readily accessible position and clearly labelled/identified.

Heaters shall have a low surface temperature, or be guarded if high surface temperature, in order to minimise the likelihood of burn injuries.

8.8 SCADA

Each power operated switching device shall be equipped with a local/remote control selector switch. The facility shall be provided to enable SCADA indication of the open/close position of this switch.

9.0 INTERLOCKING DEVICES AND PADLOCKING FACILITIES

9.1 Operational and Safety Padlocking

Padlocking arrangements shall be suitable to accommodate a WPD padlock having a 7mm diameter hasp. [ENATS 41-37 Part 1 – clauses 3.104.3 & 3.104.4]

9.2 Interlocking shall be achieved by mechanical or electro-mechanical means. Each switching device shall have provision for the fitting of key interlocks by which it will be possible to trap and release keys when the switching device is open or closed. This facility will be used in conjunction with the user's interlocking schemes.

9.3 Where mechanical interlocking is provided it shall also be possible to fit an electro-mechanical interlocking device to each mechanism such that the device is prevented from operating until the interlocking device is energised.

9.4 Electro-mechanical interlocking shall be fail safe. In the event of a loss of dc supply, blowing of fuse, removal of fuse or link should not allow the interlocking device to be defeated.

9.5 Software / IED based interlocking is not permitted.

9.6 When manually operated they shall be provided with labels which are readily visible and which contain clear concise instructions for operation.

9.7 In the event that interlocking is required to other plant items then Castell Type Q or Fortress Type H are required. Numbering/legend will be provided at the time of order.

9.8 The interlock shall be designed so that the key of the interlock is trapped when the circuit breaker is in the closed position, and is released when the circuit breaker is in the open position.

9.9 Attempted removal of the key from the circuit breaker mechanism when the circuit breaker is closed shall not trip the circuit breaker. It shall not be possible to close the circuit breaker unless the key is inserted and secured in the interlock.

10.0 PRIMARY CONNECTIONS AND MARKINGS

10.1 Terminal Palms

10.1.1 Terminal palms size 1 to 3.1.2 and Figure 1 of ENATS 41.16 are required.

10.1.2 Where these cannot be provided the Tenderer shall specify what is offered.

10.2 Labelling and Marking

Labelling and marking shall comply with ENATS 41.37 Part 1 clause 5.10 and relevant sub-clauses.

10.3 Phase Identification

10.3.1 The identity of all primary terminals shall be indelibly marked on the main structure adjacent to the terminals. The marking shall not be on removable covers.

10.3.2 Phases shall be identified in accordance with ENATS 41.37 Part 1 clause 5.10.101; that is U1 U2, V1 V2, W1 W2 for three-pole units. Any alternative offered by a supplier (for example LA, LB, LC) shall be agreed in writing by WPD where acceptable.

10.3.3 The following standard identification sequences shall apply:

Pole	Left Hand	Centre	Right Hand
Marking	U	V	W
	LA	LB	LC
CONTROL CUBICLE			

Pole Marking			
CONTROL CUBICLE	U	V	W
	LA	LB	LC

10.3.4 A set of phase identification discs shall be supplied and these shall be interchangeable on site between poles as required. The WPD requirement shall be specified at the time of order and will be selected from:

- Red / Yellow / Blue (coloured roundels)
- Black / Brown / Grey (coloured roundels)
- L1 / L2 / L3 (Black text on White)

10.3.5 Phases shall be identified consistently across all manufactured units and orders supplied to WPD.

11.0 CLEARANCES FOR OVERHEAD CONDUCTOR CONNECTED EQUIPMENT

11.1 Minimum clearance from ground level of a fixed access platform to exposed live conductors shall be basic electrical clearance (as defined in BSEN61936) plus 300mm plus personal reach. Clearance to support insulation shall be 300mm plus personal reach.

11.2 For the purposes of this specification personal reach is 2.25m.

12.0 GAS SYSTEM

12.1 Closed pressure systems for gas

The maximum relative leakage rate shall be 1% per year maximum.

12.2 Sealed pressure systems for gas

The leakage rate shall not exceed 0.5% per year.

12.3 Gas filling points

12.3.1 Gas filling points shall be fitted with self-sealing valves with a padlockable cover or closure that can be secured using a WPD standard operational padlock. [See 4.5.3 & 9.1 above.]

12.3.2 Gas filling points shall follow the colour scheme and connection type / sizing as specified in the table below:

Gas / Gas Mixture	Colour	RAL	Connection
SF ₆	Pure Orange	2004	DILO DN8 with M26 thread or DILO DN20 with M45 thread
N ₂ / O ₂ mixtures	Light Blue	5012	DILO DN12 with M30 thread or DILO DN20 with M50 thread
Mixtures containing C4-FN (C ₄ F ₇ N)	Yellow Green	6018	DILO DN8 with M28 thread or DILO DN20 with M48 thread
Mixtures containing C5-FK (C ₄ F ₁₀ N)	Telemagenta	4010	DILO DN8 with M24 thread or DILO DN20 with M43 thread
CO ₂ / O ₂ mixtures	Dusty Grey	7037	Malmquist valve with M32 thread

[Note: Table may be subject to revision to maintain alignment with future ENATS.]

- 12.3.3 These requirements shall be achieved without the use of adaptors.
- 12.3.4 All filling points shall be clearly labelled to indicate the type of gas contained within the circuit breaker.
- 12.3.5 Labels shall be engraved and mechanically secured such that they cannot be removed other than by disassembly of the circuit breaker filling point.
- 12.3.6 The same colour coding and sizing shall also be used on monitoring devices and gas handling equipment.
- 12.4 Gas monitoring and indicators
- Closed pressure systems filled with gas for insulation, operation or interruption shall be provided with a two-stage pressure/density indication.
- 12.5 Gas density gauge or indicator
- The gas density or temperature compensated gas pressure in each compartment shall be continuously monitored and indicated locally.
- The monitoring device shall provide at least two sets of alarm levels for pressure or density (alarm and minimum functions pressure or density). A means of checking initiation of the “falling” and “low” density alarms without reducing the pressure in the main circuit compartment shall be provided. This shall be achieved in such a way that operation of as much of the alarm circuit as is reasonable practical is confirmed.
- 12.6 Trip/Close lockout for low gas
- 12.6.1 In the event of low gas pressure such that the circuit breaker would be unable to interrupt full load or fault current, then operation shall be prevented.
- 12.6.2 A closed circuit breaker shall remain closed.
- 12.6.3 An open circuit breaker shall be prevented from closing.
- 12.6.4 A safety sign shall be applied adjacent to the manual mechanical open/close mandating against operation of the circuit breaker in the event that the gas pressure is below the Minimum Functional Pressure for the device. [See Appendix A1]
- The size and positioning shall be agreed by WPD for the first supplied unit, and this shall then be applied to all subsequent units supplied for installation/use on the WPD network.
- 12.7 Temporary Warning Notice
- 12.7.1 In order to try to prevent the operation of a circuit breaker until the gas fill has been completed, then temporary labels shall be attached on any manual means of closing a circuit breaker, and on the local open/close switch. [See Appendix A2]
- 12.7.2 The specific colour, wording and size shall be agreed between WPD and the manufacturer; however the design of the notice shall not resemble a safety sign required for the purposes of ensuring operator safety.

- 12.7.3 The labels shall be removed at cold commissioning once the gas fill has been satisfactorily completed.
- 12.8 Bursting discs and explosion vents
 - 12.8.1 Pressurized systems shall be provided with pressure relief devices such as bursting discs.
 - 12.8.2 Bursting disks and explosion vents shall be installed so that exhaust gasses are directed away from the normal local operating position of the circuit breaker.

13.0 RATING PLATES

- 13.1 Where equipment is provided with ratings that exceed those in this specification or order, then these higher values shall be those applied to the equipment rating plate/s.

14.0 CURRENT TRANSFORMERS

- 14.1 All connections from secondary windings shall be brought out and taken, by means of separate insulated leads, to an accessible terminal board to permit testing of individual CTs. Any joints or connections in the secondary leads shall be carried out at a terminal board.
- 14.2 Current transformer secondary windings shall have a bare wire diameter (copper) of not less than 0.8mm.
- 14.3 Current transformers shall be arranged in the turrets such that P1 faces the circuit breaker interrupter and P2 the terminal connection.
- 14.4 Rated primary and secondary currents
 - 14.4.1 Irrespective of the ratio of protective CTs, the rated continuous thermal current of the CTs (Icth) shall match the full current rating of the circuit breaker.
 - 14.4.2 For measuring CTs the rated continuous thermal current (Icth) shall be 120% of the rated primary current (Ipr) of the CT.
- 14.5 Protection current transformers
 - 14.5.1 Customary protection CT ratios, VA ratings and classes are as follows –

	Rated System Voltage	CT Ratio	VA rating & Class
Option 1	145kV	500/1	30VA 5P20
		500/1	Class PX
Option 2	145kV	1000/1	30VA 5P20
		1000/1	Class PX

- 14.5.2 Alternative ratios, VA ratings and class may be required for some CTs to match those at existing substations for specific protection scheme requirements.
- 14.5.3 Where dual ratio CTs are specified the required class, accuracy and VA rating applies to both ratios, unless otherwise stated.
- 14.5.4 Type test certificates shall be provided if required by WPD.
- 14.5.5 Each current transformer forming part of a group of CTs to provide a given function shall have a knee point voltage within 20% of the other CTs within the same group.

For example, a group of three CTs used as part of an overcurrent and earth fault protection scheme shall have knee point voltages within 20% of each other.

- 14.5.6 Class PX current transformers shall comply with BS EN 61869-2 and shall provide accurate transformation up to the maximum fault current rating of the associated main plant and ensure this performance under steady state conditions without undue saturation.
- 14.5.7 For Class PX current transformers the minimum knee point voltage requirement for each CT (V_k) is specified in the following table where R_{ct} is the d.c. secondary resistance of the CT and N is the associated CT ratio (i.e. $N = \text{CT primary current rating} \div \text{CT secondary current rating}$).

The CT secondary resistance shall be no more than 5 ohms.

- 14.5.8 In addition to the knee point requirement for Class PX current transformers, the magnetising current for each CT (I_m) shall be less than 50mA at the CT's minimum knee point voltage.
- 14.5.9 The assumptions for minimum knee point calculations for Class PX current transformers are contained in Appendix B.

Voltage	Circuit Breaker Short Circuit Withstand Rating	Protection Duty	Minimum Knee Point Voltage (V_k)
145kV	25kA or 31.5kA	Feeder Protection (eg Current Differential Protection or Distance Protection) or High Impedance Busbar Protection	$V_k > (286000 + 193000R_{ct})/N$
		Transformer Bias Differential Protection or Transformer Restricted Earth Fault Protection	$V_k > (38000 + 26000R_{ct})/N$
	40kA	Feeder Protection (eg Current Differential Protection or Distance Protection) or High Impedance Busbar Protection	$V_k > (326000 + 220000R_{ct})/N$
		Transformer Bias Differential Protection or Transformer Restricted Earth Fault Protection	$V_k > (38000 + 26000R_{ct})/N$

- 14.6 Requirements for measuring current transformers
- 14.6.1 Metering current transformers shall have independent cores and secondary windings from those provided for protection purposes.
- 14.6.2 Where dual ratio CTs are specified the required class, accuracy and VA rating applies to both ratios, unless otherwise stated.
- 14.6.3 All metering current transformers shall be to Class 0.2S rated at 15 VA unless otherwise specified.
- 14.6.4 For rated circuit capacities up to 100 MVA, one dedicated winding for settlement metering is required.
- 14.6.5 For rated circuit capacities of more than 100 MVA two windings for metering are required:
- a) Dedicated winding for Main meter
 - b) Check meter winding.

[Note: The check meter winding can also be used for other purposes, provided that overall accuracy is met and the burden of the additional load is known. The additional burden must not be changed without the approval of the Settlement System Administrator.]

- 14.6.6 The following metering CT ratios shall be available for selection as required:

200/100/1
300/150/1
400/200/1
600/300/1
800/400/1
2000/1200/1

- 14.6.7 Metering current transformers shall be tested to confirm compliance with BSEN 61869-2 but shall also be error tested on each ratio at 7.5 VA 0.9 power factor lagging burden at 5%, 20%, 100% and 120% test load points.

These additional CT errors shall either be separately tested or calculated from other error test results.

- 14.6.8 Electronic copies of the of test certificates in PDF format, including any error tests used as the basis of the calculations described above, shall be provided in advance of delivery for each metering current transformer.

These shall be sent to the WPD project engineer by electronic mail.

A hard copy of the test certificate/s shall accompany any circuit breaker in which a metering current transformer is installed.

- 14.7 During a tender process the manufacturer will be require to offer the circuit breaker with one or more standard sets of CTs installed.

The manufacturer will also be required to provide an offer based around a base circuit breaker and a list of standard CTs of different types for selection and installation.

- 14.8 Where non-standard CTs are required on a circuit breaker then it is accepted that a price variation over the standard CTs will be provided by the manufacturer on a case by case basis.
- 14.9 CT requirements are summarised in Schedule C.
- 14.10 Specimen current transformer arrangements for tendering purposes are in Schedule D.
- 14.11 Additional current transformers for dedicated indication use.
- 14.11.1 Where additional current transformers are required for dedicated indication purposes they shall be Class 0.5S.
- 14.11.2 Their ratio shall be 1000/1.
- 14.11.3 Their rated burden shall be 15VA.
- 14.12 Additional current transformers for customer Import/Export limitation Schemes and/or G99 monitoring systems
- 14.12.1 Where current transformers are required for use with customer Import/Export Limitation Schemes and/or monitoring systems required by Engineering Recommendation G99 "*Requirements for the connection of generation equipment in parallel with public distribution networks*", then these should meet the requirements of both measurement Class 0.2 and protection class 5P20.
- 14.12.2 Their ratio shall be 1000/1.
- 14.12.3 Their rated burden shall be 15VA.
- 14.13 Additional protection current transformers for customer sole use
- Where a customer requires specific current transformers as part of their equipment protection scheme (eg. transformer protection) then these may be provided to customer specification and at customer cost.
- 14.14 Where additional current transformers as in 14.11, 14.12 and/or 14.13 above are required, then their provision can only be accomplished provided that it does not compromise the specific current transformer ratios, class and ratings etc required for WPD use.

15.0 INSTALLATION AND COMMISSIONING TESTS

- 15.1 The manufacturer shall carry out the site works to install, test and cold commission the circuit breaker in conjunction with WPD in accordance with Schedule X of this specification.
- 15.2 Any changes to this shall be agreed in writing by WPD either by the Engineering Policy Team for the overall contract arrangements or by the WPD Site Project Engineer on a specific site basis.

15.3 The manufacturer shall provide a price at the time of tender for these activities that is separate to the price for the circuit breaker.

16.0 DRAWINGS

16.1 The manufacturer shall provide the following drawings for approval within one month of the commencement date of the contract or by mutually agreed date at the placement of the order:

- General Arrangement of each circuit breaker / cubicle
- Schematic Diagram for each circuit breaker / cubicle
- Wiring diagram for each circuit breaker / cubicle

16.2 The manufacturer shall provide a composite DC schematic diagram which includes all parts of the DC circuits within the circuit breaker.

The manufacturer may also provide individual sheets for each element of the DC circuitry however these shall not be a replacement for the composite DC schematic diagram.

16.3 Once approval has been obtained an additional copy of the drawings shall be provided.

16.4 After on-site installation and commissioning has been completed the manufacturer shall incorporate any alterations within 3 months of the drawings being returned for correction and provide a final copy of the drawings.

16.5 All drawings shall be provided electronically in .dwg CAD format.

17.0 TEST RESULTS

17.1 The manufacturer shall provide copies of test results following completion of factory routine tests and site cold commissioning tests.

17.2 These shall be provided in hardcopy and electronically in .pdf format to the WPD project engineer responsible for the works.

18.0 DOCUMENTATION TO BE PROVIDED AT TIME OF TENDER

The manufacturer shall provide the following list of documents or information at the time of tender:

- Installation, operation and maintenance manuals
- Summary of recommended inspection and maintenance requirements
- Recommended parts list
- Details of site commissioning tests
- End-of-Life disposal information/guide

19.0 TYPE TESTS

Type tests shall be as per BSEN 62271-100 clause 6, clause 6 of ENATS 41-37 Part 1 and clause 6 of ENATS 41-37 Part3.

20.0 ROUTINE TESTS

Routine tests shall be as per clause 7 of ENATS 41-37 Part 1 and BSEN 62271-100 clauses 7.1 to 7.101.

WPD SPECIFIC SAFETY SIGNS AND WARNING NOTICES

A1 Safety Notice

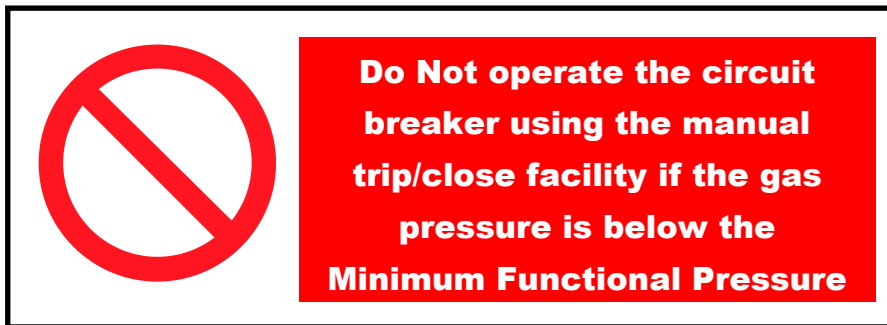

A2 Temporary Warning Notice

WARNING
This circuit breaker shall not be closed and/or opened by manual or electrical means until the gas fill has been completed.

ASSUMPTIONS FOR MINIMUM KNEE POINT CALCULATIONS FOR CLASS PX CURRENT TRANSFORMERS

The Class PX current transformer minimum knee-point calculations are based on the following assumptions:

- A maximum multicore length 100m (of 2.5mm² copper multicore).

[Note:- Longer multicore lengths can be accommodated by increasing the cross-section or by doubling up on the cores.]

- The current transformer secondary resistance (for individual current transformers) is up to 5 ohms.
- The fault level at the circuit breaker is equal to the circuit breaker rated short-circuit breaking current (40kA or 31.5kA) with a network X/R ratio of 10.

[Note:- The impact of higher X/R ratios are mitigated to some extent by the assumed minimum circuit impedance.]

- Operating at nominal voltage.
- The minimum circuit impedance for feeder protection (e.g. at end of Zone 1 reach = 0.5 ohms at 65°C).
- The maximum through fault current (referred to HV side of transformer) for a transformer bias differential protection and transformer restricted earth fault protection (REF) is based on ENA TS 48-3 (i.e. 16x transformer rating).

SUPERSEDED DOCUMENTATION

This is a new specification that supersedes relevant sections in EESPEC 7.

EESPEC 7 will be withdrawn once all sections and equipment are covered by new EESPECs.

ASSOCIATED DOCUMENTATION

ENA TS 41-37 Part 1 - Issue 2	Switchgear for use on 66kV and 132kV distribution systems – Part 1 Common clauses
ENA TS 41-37 Part 3 - Issue 2	Switchgear for use on 66kV and 132kV distribution systems – Part 3 Alternating Current Circuit Breakers
ENA TS 41-24	Guidelines for design, installation, testing and maintenance of main earthing systems in substations
ENA TS 41-38	Power installations exceeding 1kVac – Design of high-voltage open-terminal stations
ENA TS 50-18 EE SPEC: 136	Application of ancillary electrical equipment Ancillary Electrical Equipment for Use in Conjunction with Switchgear and Protection/Control Panels

IMPACT ON COMPANY POLICY

None.

RECORD OF COMMENTS DURING CONSULTATION

No comments received during formal comment process.

IMPLEMENTATION OF POLICY

This document may be implemented on issue for new tenders and contracts.

This specification is not retrospective for current contracts based on EEPSEC 7/3.

KEYWORDS

Circuit Breaker, Dead Tank, 145kV, 132kV

SCHEDULE A – WPD Requirements for 145kV Dead Tank Circuit Breaker

Information	Sub-clause of ENATS 41-37 Part1	WPD requirement
Particulars of system		
Voltage kV		145
Frequency Hz		50
Number of phases		3
Neutral earthing		Solid
Switch characteristics		
Number of poles		3
Class	1.2	Outdoor -25°C to +40°C
Nominal Voltage U_n (kV)		132
Rated Voltage U_{Ne} (kV)	4.1	145
Rated power frequency withstand voltage U_d (kV)	4.2	275
Rated lightning impulse withstand voltage U_p (kV)	4.2	650
Rated frequency (Hz) f_r	4.3	50
Rated Normal current (A) I_r	4.4	2500
Rated short-time withstand current (kA) I_k	4.5	≥ 31.5
Rated duration of short circuit (sec) t_k	4.7	3
Rated short-circuit breaking current I_{SC} (kA)	4.101	Equal to rated short-time withstand current.
Rated short-circuit making current (kA)	4.6 / 4.103	2.7 times rated short-circuit breaking current
Voltage factor (k_p)		1.4
First pole to clear factor (k_{pp})		1.5
Rated supply voltage of opening and closing devices, and auxiliary and control circuits U_a <ul style="list-style-type: none"> • Closing & tripping • Indication • Control 	4.8	110Vdc
Rated supply frequency of closing and opening and of auxiliary circuits	4.9	dc
Rated operating sequence	4.104	O - 0.3s – CO - 3min - CO
Classification in regard of electrical endurance	4.111	Class M1
Classification of mechanical operations	4.110	Class M1 - 2000
Rated capacitive switching currents	4.107	Class C2
Rated cable-charging breaking current I_c (A)	4.107	160
Rated line charging breaking current I_l (A)	4.107	50
Gas monitoring indicator	5.9.101	-Pressure/density gauge/indicator -Two stage pressure switch

SCHEDULE B – Manufacturer Declaration for 145kV Dead Tank Circuit Breaker

Information	Declaration
Mechanism type	
Closing mechanism power consumption (mA) and duration of consumption (s)	
Operating time – Close operation (ms)	
Operating Time – Open operation (ms)	
Noise (during operation and/or activity) (dB)	
Arc interruption medium	
Insulation medium	
Type of gas	
Mass of gas (kg)	
Rated filling pressure	
Alarm pressure	
Minimum functional pressure	
Mass of complete unit (kg)	
Maximum dynamic floor/support loading(s) (kN)	
Dimensions (m)	
AIS bushing details	
Colour of paint	
Additional information	

SCHEDULE C – Current Transformer Requirements

Customary CT Ratios, VA Rating and Class

CT Class	Standard Protection	Class PX - Feeder	Class PX - High Impedance
Class of accuracy	5P	X	X
Rated accuracy limit factor	20	-	-
Rated transformation current ratio	500/1 or 1000/1	500/1 or 1000/1	500/1 or 1000/1
Nominal turns ratio	500/1 or 1000/1	500/1 or 1000/1	500/1 or 1000/1
Primary rated current	2500A	2500A	2500A
Rated continuous thermal current	2500A	2500A	2500A
Rated short time current & duration	40kA / 31.5kA	40kA / 31.5kA	40kA / 31.5kA
Max secondary winding resistance (Rct)	-		
System power frequency	50Hz	50Hz	50Hz
Insulation level (secondary)	3kV rms	3kV rms	3kV rms
Rated burden	30VA	-	-
Knee-point emf	-		
Limits on exciting current	-	50mA	50mA

Special Requirements for Non-Standard CTs

CT Class	Class PX - Feeder	Class PX - High Impedance	Standard Protection
Class of accuracy	X	X	5P
Rated accuracy limit factor	-	-	20
Rated transformation current ratio			
Nominal turns ratio			
Primary rated current	2500A	2500A	2500A
Rated continuous thermal current	2500A	2500A	2500A
Rated short time current & duration	40kA / 31.5kA	40kA / 31.5kA	40kA / 31.5kA
Max secondary winding resistance (Rct)			-
System power frequency	50Hz	50Hz	50Hz
Insulation level (secondary)	3kV rms	3kV rms	3kV rms
Rated burden	-	-	
Knee-point emf			-
Limits on exciting current	50mA	50mA	-

SCHEDULE D – Sample CT Arrangements for Tendering Purposes

Feeder - Distance Protection

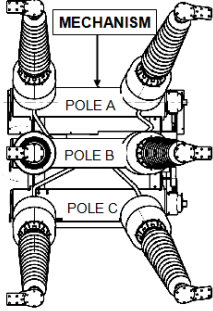
	Top	Middle	Bottom	Turret		Turret	Bottom	Middle	Top
Pole A	PX 500/1	PX 500/1	PX 500/1	1		2	5P20 1000/1	5P20 1000/1	PX 500/1
Pole B	PX 500/1	PX 500/1	PX 500/1	3		4	5P20 1000/1	5P20 1000/1	PX 500/1
Pole C	PX 500/1	PX 500/1	PX 500/1	5		6	5P20 1000/1	5P20 1000/1	PX 500/1

Feeder – Unit Protection

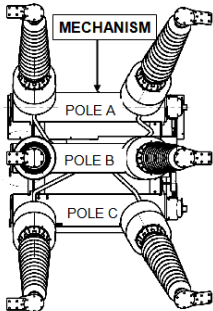
	Top	Middle	Bottom	Turret		Turret	Bottom	Middle	Top
Pole A	PX 500/1	PX 500/1	PX 500/1	1		2	5P20 1000/1	5P20 1000/1	PX 500/1
Pole B	PX 500/1	PX 500/1	PX 500/1	3		4	5P20 1000/1	5P20 1000/1	PX 500/1
Pole C	PX 500/1	PX 500/1	PX 500/1	5		6	5P20 1000/1	5P20 1000/1	PX 500/1

Transformer

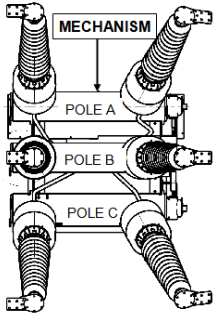
	Top	Middle	Bottom	Turret		Turret	Bottom	Middle	Top
Pole A	PX 500/1	PX 500/1	PX 500/1	1		2	5P20 1000/1	5P20 1000/1	PX 500/1
Pole B	PX 500/1	PX 500/1	PX 500/1	3		4	5P20 1000/1	5P20 1000/1	PX 500/1
Pole C	PX 500/1	PX 500/1	PX 500/1	5		6	5P20 1000/1	5P20 1000/1	PX 500/1

Bus Section

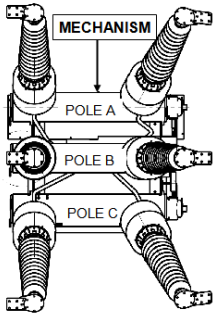
	Top	Middle	Bottom	Turret		Turret	Bottom	Middle	Top
Pole A	PX 500/1	PX 1000/1	5P20 1000/1	1		2	5P20 1000/1	5P20 1000/1	PX 500/1
Pole B	PX 500/1	PX 1000/1	5P20 1000/1	3		4	5P20 1000/1	5P20 1000/1	PX 500/1
Pole C	PX 500/1	PX 1000/1	5P20 1000/1	5		6	5P20 1000/1	5P20 1000/1	PX 500/1

Metering

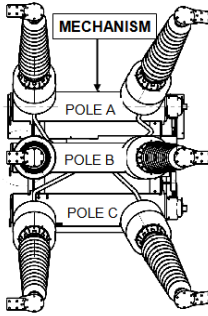
	Top	Middle	Bottom	Turret		Turret	Bottom	Middle	Top
Pole A	PX 500/ 1	5P20 500/1	0.2S 200/100 /1	1		2	0.5S 1000/ 1	5P20 500/1	PX 500/1
Pole B	PX 500/ 1	5P20 500/1	0.2S 200/100 /1	3		4	0.5S 1000/ 1	5P20 500/1	PX 500/1
Pole C	PX 500/ 1	5P20 500/1	0.2S 200/100 /1	5		6	0.5S 1000/ 1	5P20 500/1	PX 500/1

SCHEDULE X - Scope and Responsibilities for Site Works

	Manufacturer	WPD
Pre-site Visit Activity	<ul style="list-style-type: none"> • Liaison with Client • Supply, as requested, documentation required for CDM including relevant schedule of work, method statements, risk assessments, training/qualifications 	<ul style="list-style-type: none"> • Liaison with Manufacturer • Request documentation as necessary for site H&S requirements / CDM • Installation / preparation of foundations
Delivery*	<ul style="list-style-type: none"> • Off-loading of delivery lorry 	<ul style="list-style-type: none"> • Site induction as required for delivery • Access for delivery vehicle • Hard-standing area for off-loading
First Site Visit*	<ul style="list-style-type: none"> • Removal of packing material • Inspection for damage to insulators, gas piping, covers etc. during shipping • Supply and installation of "Hilti" type chemical anchors • Assembly of support structure and location on foundations • Install circuit breaker on support structure 	<ul style="list-style-type: none"> • Site induction • Site supervision • Provision of welfare facilities • Power supply for construction tools • Movement of equipment from off-loading area to installation position
Between Site Visits		<ul style="list-style-type: none"> • Connect circuit breaker to substation earth • Complete secondary wiring to circuit breaker • Install HV busbars
Second Site Visit	<ul style="list-style-type: none"> • Check SF6/gas system for gas-tightness • Fill circuit breaker with SF6/gas to rated/normal working pressure • Test SF6/gas from circuit breaker for impurities and dew-point <p>Complete cold commissioning:-</p> <ul style="list-style-type: none"> • Verify low gas alarm • Inspect mechanism/functional tests • Inspect auxiliary system • Check control system components • Insulation tests • CT injection testing (#) • Measure contact resistance • Timing Tests / pole synchronisation • Fill out commissioning sheets 	<ul style="list-style-type: none"> • Site induction • Site supervision • Safety Documents • Power supply for test equipment etc • Provide means of access (MEWP) for connection of test leads • Provision of general helper to assist with test lead connection etc

[* Delivery to be combined with first site visit where possible and practicable.]

[# Requirement applies to dead tank circuit breakers only.]