



# National Grid Electricity Distribution

## 66kV Outdoor Metered Connections - Guidance For Substation Designers Version 7

*All references to Western Power Distribution or WPD must be read as National Grid Electricity Distribution or NGED*

May 2022

## Contents

Section 1.	<a href="#"><u>Introduction</u></a>
Section 2.	<a href="#"><u>Design Submission/ Approval Process</u></a>
Section 3.	<a href="#"><u>Switchgear Technical &amp; Protection Requirements</u></a>
Section 4.	<a href="#"><u>Metering VT and CT Requirements</u></a>
Section 5.	<a href="#"><u>Operational Configuration of WPD Switchgear</u></a>
Section 6.	<a href="#"><u>Customers Switchgear Earth Facility</u></a>
Section 7.	<a href="#"><u>Generator Interface Protection</u></a>
Section 8.	<a href="#"><u>Substation LVAC Supplies &amp; Building Services</u></a>
Section 9.	<a href="#"><u>Substation DC Supplies</u></a>
Section 10.	<a href="#"><u>SCADA and RTU Interface Cabling</u></a>
Section 11.	<a href="#"><u>Connection Control Panel (CCP)</u></a>
Section 12.	<a href="#"><u>Connection Control Interface Box</u></a>
Section 13.	<a href="#"><u>WPD Compound and Control Room Specification</u></a>
Section 14.	<a href="#"><u>Earthing Requirements</u></a>
Section 15.	<a href="#"><u>Metering Equipment Accommodation</u></a>
Section 16.	<a href="#"><u>Substation Communications Infrastructure</u></a>
Appendix A.	<a href="#"><u>Earthing Checklist</u></a>

## Major Changes in this Version

- Change includes removal of GRP from building specifications this is now not approved

# 1 Introduction

This document has been prepared primarily to assist Independent Connection Providers (ICP's) with the design and specification of 66kV substation assets for adoption by Western Power Distribution (WPD). It may also be of broader interest to our Customers, their consultants and contractors. We hope that the information in this document will enable ICP's to streamline the design submission process but the document also has applicability to 66kV connection projects for which such a process is not required in full.

The document applies to embedded generator and demand connection projects where the Point of Connection is the 66kV system and a single circuit outdoor switchgear solution is envisaged. It relates to the detailed requisites of substation design rather than those of underground cable, or overhead line design.

It is not intended that this document be used as a detailed reference for power systems analysis, network modelling or power quality aspects of a particular connection. Our particular requirements in this respect will generally be defined within the connection offer prepared and issued by our Primary System Design Team.

Although this document makes some reference to the degree of contestability that may be expected for certain connection works, project-specific connection offer documentation should always be consulted for more detailed understanding.

WPD have a duty of care to ensure that substation environments provide suitable conditions to safely accommodate our electrical apparatus such that it does not present an unacceptable hazard to Customers, WPD employees, contractors and the public. Relevant legislation in this arena includes:

- The Electricity Supply Quality and Continuity Regulations
- The Electricity at Work Regulations
- The Workplace (Health, Safety and Welfare) Regulations
- The Management of Health and Safety at Work Regulations
- The Construction Design and Management Regulations

Before energising a connection to the WPD network, we must satisfy ourselves that it is so constructed, installed and protected (both electrically and mechanically), to prevent danger, interference with, or interruption of supply, so far as is reasonably practicable. We must also ensure that the substation environment is constructed so as to prevent, as far as is reasonably practicable, danger and unauthorised access.

In recognition of the above, we acknowledge the importance to all project stakeholders of us clearly identifying WPD criteria for acceptance/ adoption at the earliest opportunity. We believe that this should best enable substation designers to incorporate the requisites of WPD approval into their submissions.

Although this document has been produced to be compliant with appropriate WPD policy documents relating to 66kV connections, it supplements, rather than supersedes these documents. Particular WPD policy documents should always be consulted for detailed guidance and these are referenced within this document (and often within project-specific connection offer paperwork) where relevant.

**WPD policy documents are available online to subscribers to our technical website [www.westernpowertechinfo.co.uk](http://www.westernpowertechinfo.co.uk). This service is provided free of charge to users once they have completed an online registration.**

## 2 Design Submission and Approval Process

Where formal assessment and approval of an ICP design is required for a connection project, the ICP's design submission should comprise sufficient project-specific information for us to assess the suitability of these proposals for adoption (and connection to our network).

The ICP should provide full and comprehensive designs for all of the plant and equipment proposed for adoption by us. Additionally, the ICP shall submit sufficient design data to enable us to confirm that the substation compound and civil features are designed to provide a suitable environment for our equipment.

It is essential that we are afforded sufficient information to enable us to assess the validity of the design of the adoptable assets and of any infrastructure directly related to these assets. To afford the most comprehensive and efficient design submission response to the Customer, via their ICP, we would ideally seek a comprehensive design submission including all aspects of the adoptable assets.

Notwithstanding the above, we recognise that there are occasions where connection timeframes may require the Customer's ICP to submit designs for long-lead plant items and civil features in advance of having completed detailed protection designs and/ or earthing study and design work. In such circumstances we will assess whether partial submissions contain sufficient data to enable a relevant partial approval to be granted.

Incomplete designs may be rejected if they do not provide sufficient detail to enable the validity of the relevant design aspect, as a whole, to be assessed.

The design submission shall be in electronic format, via email to the designated WPD Primary System Design contact. Due to mailbox constraints, we would ask that email submissions are restricted to a maximum size of 10MB per transmittal. Drawings should be submitted in .dwg (AutoCAD 2010) format.

Although the WPD Primary System Design Engineer will remain the focal Customer contact during the design approval process, a number of specialist engineers within the organisation will assess particular elements of the design submission. In order that we may minimise response times we would ask that the design data is subdivided such that we may internally distribute the right information to the right respondents swiftly. We would recommend that data is subdivided under functional headings detailed below and to assist assessment.

## 66kV Metered Connection – Indicative Design Submission Components

Information Type	Probable Component Parts
Section A - <b>Electrical Design</b>	<ul style="list-style-type: none"> <li>• Overall single-line diagram/ network design of Customers installation</li> <li>• Ditto Main Connections and Protection Diagram</li> </ul>
Section B – <b>EHV Switchgear Design</b>	<ul style="list-style-type: none"> <li>• Switchgear and other primary equipment manufacturers submission indicating type, variant, ratings etc</li> <li>• Supporting manufacturers literature/ technical datasheets</li> <li>• General Arrangement drawings including cabling and holding down details.</li> <li>• Main Connections &amp; Protection Diagram, showing tripping to and from the Customer’s equipment.</li> <li>• Single Line Diagram, showing physical arrangements</li> <li>• Mechanical/ Electrical Interlocking Diagram</li> <li>• Schematic Diagrams (AC and DC) showing protection, instrumentation and metering arrangements and terminal block presentation.</li> <li>• List of protection relays with full model numbers.</li> </ul>
Section C – <b>Substation Civil Design</b>	<ul style="list-style-type: none"> <li>• Substation location plan, showing access roads from the public highway</li> <li>• Substation compound layout</li> <li>• Control Room civil drawings, showing structure and substructure materials and construction, access doors, cable and multicore cable trench details</li> <li>• Substation compound civil drawings showing foundation designs, ground-works, roads, drainage, fencing, multicore cable troughs/ ducts etc</li> <li>• Control Room electrical equipment layout drawing/s (also showing LVAC fit-out)</li> <li>• Site flood risk assessment</li> </ul>
Section D - <b>Earthing Design</b>	<ul style="list-style-type: none"> <li>• Site earthing study and interpretive report</li> <li>• Confirmation of hot/ cold status of the site and proposed mitigation measures for the former</li> <li>• Description of proposed earthing materials/ jointing techniques etc</li> <li>• Earthing layout drawing</li> </ul>
Section E – <b>DC Battery System Design</b>	<ul style="list-style-type: none"> <li>• 110V Battery/ charger manufacturer, type, ratings and supporting specification/information.</li> <li>• 110V Battery/ charger/ DC distribution board general arrangement drawings/ schematic drawings</li> <li>• Ditto 48V/ 24V telecontrol battery/ charger/ distribution board where applicable</li> </ul>
Section F - <b>132kV Overhead Line (OHL) Design</b>	<ul style="list-style-type: none"> <li>• OHL construction details</li> <li>• OHL Disconnector manufacturer, type, ratings and supporting specification/information.</li> <li>• OHL route plans</li> </ul>
Section G – <b>132kV Underground Cable Design</b>	<ul style="list-style-type: none"> <li>• Cable, joint and terminations manufacturer, type, ratings and supporting specification/information</li> <li>• Cable route plans</li> </ul>
Section H – <b>Substation Communications Infrastructure Design</b>	<ul style="list-style-type: none"> <li>• Substation microwave comms tower design (where applicable)</li> <li>• Substation microwave comms tower foundation designs (ditto)</li> <li>• Substation fibre comms route plans</li> <li>• Substation fibre comms route chamber designs</li> </ul>

## 3 Switchgear Technical and Protection Requirements

WPD competitively tender the supply of switchgear and associated equipment on a term basis. In this way, stakeholders may benefit from economies of scale, both commercially and in terms of being able to minimise design input by establishing generic arrangements. We currently have 66kV outdoor switchgear framework arrangements in place for the purchase of:

- UK Grid Solutions type DT1 72.5kV

It may be advantageous for a Customer to benefit from the use of the designs/ specifications based upon the above switchgear, although alternatives may be offered to WPD by the Customer for consideration, assuming that they meet our acceptance criteria.

WPD's technical requirements for 66kV outdoor circuit breakers, disconnectors, VT's and CT's are described in [Engineering Specification: EE Spec 7](#).

WPD's technical requirements for protection and control cubicles are described in [Engineering Specification: EE Spec 87](#).

WPD's technical requirements for ancillary equipment for use in conjunction with switchgear and protection/control panels are described in [Engineering Specification: EE Spec 136](#).

Section 5 of this document shows typical arrangements for single circuit teed and single circuit looped connections. The table overleaf provide a broad overview of the technical and protection requirements for such arrangements:



Description	36C11A (Outdoor)  Incoming Circuit with Metering
Standard Drawings * Single Line Diagram Schematic Diagram	SL36C11A (OUTDOOR) SPC36C11A (OUTDOOR)
Pollution Level	Level iv (31mm/kV)
Rated Voltage kV	72kV
Rated Insulation Level (lightning impulse withstand voltage) kV	325kV
Rated Normal Current A	2500A
Rated Short Time Withstand Current kA	31.5kA
Rated DC time constant ms	120ms
Tripping & Closing Supplies	110V DC
<b>CT's and VT's</b>	
CT's for customer use The customer is to provide instantaneous protection across the WPD metering CB and the customers transformer. WPD will accommodate a set of the customers CT's in the metering CB for this purpose.  Class PX The customer shall provide the full CT specification	One set of 3
CT's for Overcurrent and Earth Fault protection 800/1 30VA 5P20 (2500A continuous rating)	One set of 3
CT's for Transducer and GCP 800/1 15VA Class 0.5S (2500A continuous rating)	One set of 3
CT's for Metering Ratio to agreed, 15VA Class 0.2S (120% continuous thermal rating)	For circuit capacities up to 100MVA, one set of 3  For circuit capacities over 100MVA, two sets of 3
Voltage Transformer 66000/√3 : 110/√3 : 110/√3 : 110/√3 Star/Star/Star/Open Delta For circuit capacities up to 100MVA Class 0.5/3P For circuit capacities over 100MVA Class 0.2/3P	3 off single phase
<b>Control/Relay Cubicle</b>	
Circuit breaker control switch and handle	1
Local/Supervisory switch and handle	1
Telecontrol CB open interposing relay	1
Telecontrol CB Close interposing relay	1

Current/Voltage/MW/MVAR Transducer	1
Main Protection Relay/s	3HSOC 3DOCIT DEIT 3OCIT EIT NVD VTS
Trip/Intertrip Relay	TDS
Customer Trip Flag Relay	TI
SF6 Gas Low	A (SF6 Low) All stages
Spring Charge Fail	A (SCF)
Trip Circuit Supervision	TCS
Test Block	TTB (3off)
CB Indication/Spring Charged Lamps	3 off
Switched Indication Supply Equipment	1 off AC/DC Aux Relay 1 off 240/110V Tx AC/DC/OFF Switch
Terminal Blocks	As Required
Fuses & Links	As Required

\* It should be noted that there are small differences in the configuration of switchgear deployed in S Wales with that deployed within our other licence areas. These differences are predominately related to telecontrol voltage/ polarity requirements and we are currently unable to harmonise specifications. Telecontrol interposing functions specified for use in the S West, W Mids and E Mids are not suitable for installation in S Wales and vice-versa.

WPD standard drawing SPC215 shows telecontrol interposing relay polarity for South Wales 24V battery systems.

All protection and ancillary relays must be of a type/ designation approved by WPD. The standard schematic diagrams show the protection relay types applicable to the scheme. Full details of all WPD approved relays, including their respective CORTEC identifier can be found in [Engineering Specification: EE Spec 98](#).

The standard schematic diagrams show a generic switchgear arrangement and are not specific to a particular connection. Detailed protection scheme design (such that may include WPD/Customer intertripping, alarms and more complex protection requirements) will be advised on a project-specific basis and it will be the responsibility of the Customer to deliver certain outputs in this respect. In the main, the Customer should assume that the following facilities will be required (in addition to WPD circuit protection):

- Close-inhibit of the WPD metering breaker (to prevent it being closed unless the Customer's interface breaker is open)
- Intertrip send (and receive) facilities between the WPD metering breaker and the Customer's interface protection

An emergency trip button (break glass type) shall be provided that will enable the Customer to trip the WPD circuit breaker. The emergency trip will be located in the Customer's accommodation in a location that the Customer feels is optimal for the connection. In assessing prospective locations, the Customer would logically wish to identify areas to which potential site occupants have prompt access in an emergency.

We specify that the Customer's points of automatic disconnection will be located no more than 100 metres from the WPD metering breaker in order that multicore cable intertripping, emergency break glass tripping facilities and overvoltage constraint functions remain functional under all conditions. We reserve the right to request multi-core cable volt-drop calculations from the Customer to confirm effective operation of these facilities at the upper limit of separation distance.

## 4 Metering CT and VT Requirements

Elxon's Code of Practice Two (COP2) applies to the metering of circuits with a rated capacity between 10MVA and 100MVA. Code of Practice One (COP1) applies to the metering of circuits with a rated capacity in excess of 100MVA. Instrument transformer selection and configuration shall be as defined within the relevant COP guidance for the circuit capacity of the proposed connection.

Metering facilities shall be provided in accordance with the requirements of [ST: TP14C – Distribution Business Provided Metering Facilities](#).

Instrument transformers shall be error tested in accordance with the requirements of [ST: TP14C – Distribution Business Provided Metering Facilities](#) and [EE Spec:7](#).

Test certificates are to be provided in accordance with the requirements of [ST: TP14J – Management of Metering CT & VT Test Certificates](#).

### Voltage Transformer

The Voltage Transformer shall be three of single phase electromagnetic type and should meet the following criteria:

Rated voltage 72kV  
Ratio 38106/63.5/63.5/63.5  
Star/Star/Star/Open Delta  
Minimum rating of 100VA for all windings  
Voltage factor 1.9 for 30 seconds

For circuit capacities up to 100MVA, all windings shall satisfy the requirements for both Class 0.5 and Class 3P.

For circuit capacities over 100MVA, all windings shall satisfy the requirements for both Class 0.2 and Class 3P.

The total burden on metering VT secondary winding shall be between 25% and 100% of the rated burden.

The VT's shall be solely for WPD use and shall not be used directly to provide a voltage reference for Customer synchronisation or interface protection.

## Metering Current Transformers

Dual ratio metering CT's are to be provided for 132kV connections and are to be selected in accordance with [ST: TP14C – Distribution Business Provided Metering Facilities](#). Preferred ratios are given below for information:

100/50/1\*  
200/100/1  
300/150/1  
400/200/1  
600/300/1  
800/400/1  
1200/600/1  
1600/800/1  
2000/1000/1

\* As switchgear manufacturers often have difficulty accommodating this ratio within their switchgear the next highest ratio may be substituted where necessary.

Metering CT's shall have a 15VA rating and satisfy the requirements of Class 0.2S. For circuit capacities up to 100MVA, one dedicated set of CT's is required. For circuit capacities above 100MVA, two dedicated sets of CT's are required.

The total burden on metering CT's shall be between 25% and 100% of the rated burden.

## 5 Operational Requirements for WPD Switchgear

The connection arrangement will be determined by WPD's Primary System Design team, dependent on network considerations. The following options describe WPD's preferred switchgear arrangements for simple teed and looped connections.

Actual arrangements may differ depending on the design and manufacturer of the switchgear being considered and WPD's protection requirements. The operational requirements listed below must be satisfied in all circumstances:

### Single Circuit Teed Connection

- The CB interlock key 1H0 shall only be released with the CB in the open position.
- Disconnectors 1L3 and 1H3 shall only operate with interlock key 1H0 inserted. Key 1H0 shall be trapped during operation, but released with the Disconnector in the open or closed position.
- Disconnector 1L3 shall release a key 1L3 when in the open position.
- Line Earth Switch 1L1 shall only operate with key 1L3 inserted. Key 1L3 shall be trapped during operation and when the switch is closed to earth. It shall only be released with the earth switch opened from earth.

See overleaf for single line diagram

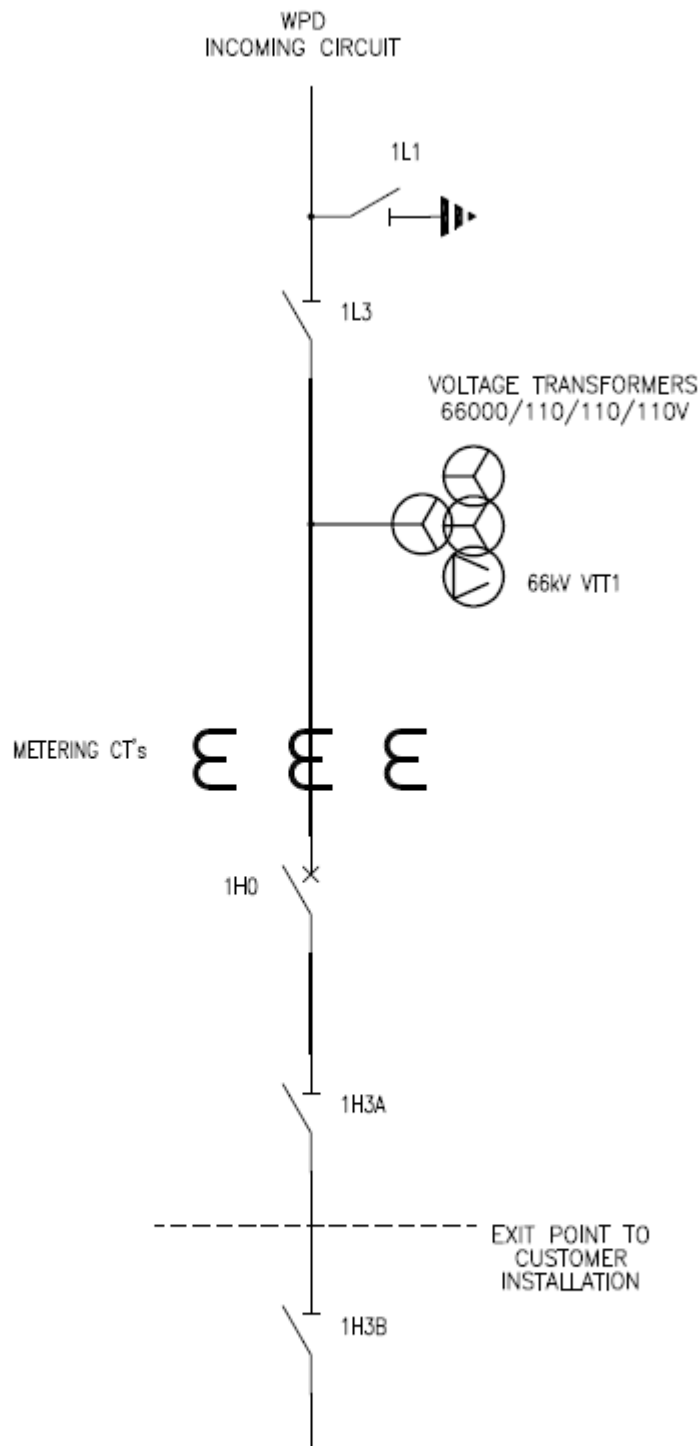

NOMENCLATURE SHOWN  
IS TYPICAL ONLY.  
WPD TO CONFIRM  
REQUIREMENTS.

SINGLE CIRCUIT  
TEED CONNECTION

## Single Circuit Teed/Looped Connection

- The CB interlock key 1H0 shall only be released with the CB in the open position.
- Disconnectors' 1H3, 1H4, 3L3 & 5L3 shall only operate with interlock key 1H0 inserted. Key 1H0 shall be trapped during operation, but released with the Disconnector in the open or closed position.
- Disconnectors' 3L3 & 5L3 will not be fully interlocked with this network arrangement. A warning label shall be attached at the operating position of these disconnectors'.
- Disconnector 3L3 shall release a key 3L3 when in the open position.
- Line Earth Switch 3L1 shall only operate with key 3L3 inserted. Key 3L3 shall be trapped during operation and when the switch is closed to earth. It shall only be released with the earth switch opened from earth.
- Disconnector 5L3 shall release a key 5L3 when in the open position.
- Line Earth Switch 5L1 shall only operate with key 5L3 inserted. Key 5L3 shall be trapped during operation and when the switch is closed to earth. It shall only be released with the earth switch opened from earth.

See overleaf for single line diagram



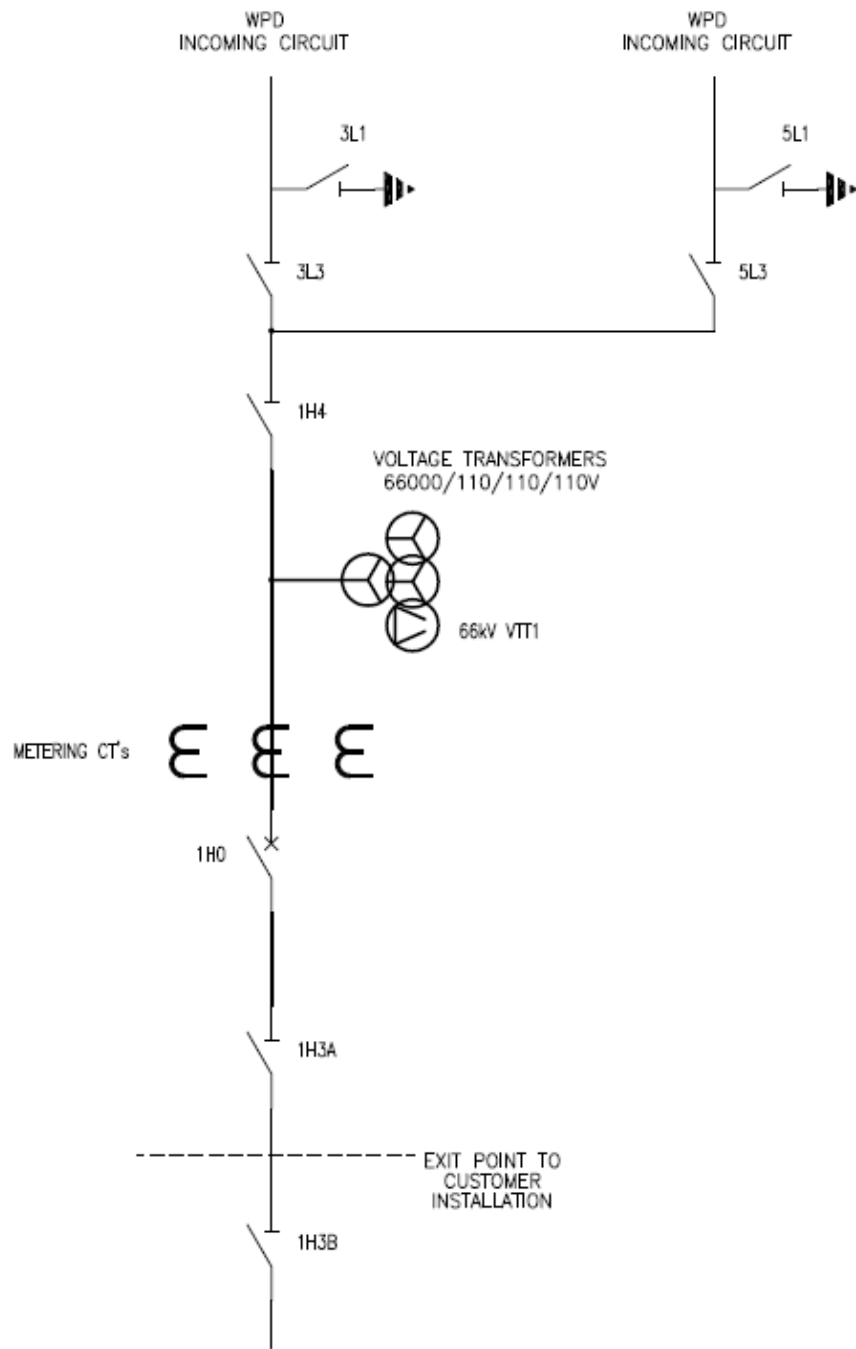

NOMENCLATURE SHOWN  
IS TYPICAL ONLY.  
WPD TO CONFIRM  
REQUIREMENTS.

SINGLE CIRCUIT  
LOOPED CONNECTION

## 6 Customer Switchgear Earth Facility

This will generally be the responsibility of the Customer to determine. The Customer should have a facility to apply a fully-rated earth towards the WPD equipment. If the connection from WPD equipment terminates directly onto a Customer's transformer, then it is acceptable for the earth facility to be provided on the LV side of the transformer.

# 7 Generator Interface Protection

## Generator Interface Protection Generally

It is the customer's responsibility to ensure that the operation of any generators in parallel with WPD's Distribution System conforms to National Engineering Recommendations, as amended from time to time. This will include a requirement for interface protection, including loss of mains protection. The detail of this protection is to be agreed with WPD.

It is anticipated that Customers will be aware that with effect from 27<sup>th</sup> April 2019 their installations should comply with ENA Engineering Recommendation G99 (Requirements for the Connection of Generation Equipment in Parallel with Public Distribution Networks). These GB codes define the national application of the European Connection Code : Requirement for Generators (RfG).

Please note that unless you have signed an exemption with us by providing evidence of a signed contract, from Midnight on 26<sup>th</sup> April 2019, we will only allow generation to be connected that is EREC G99 compliant.

## 8 Substation LVAC Supplies and Building Services

### Derivation of LVAC Supply

The degree of resilience of the LVAC supply to the substation will be determined based upon the criticality, to our broader network of any protection systems at the site. Before proposing an LVAC solution, it is recommended that the ICP has project-specific dialogue with WPD over the criticality of protection or communications systems at the site.

Where it is confirmed that no WPD protection/ communications systems will be present at the metering substation that are considered to be critical to the security of our broader 66kV network LVAC supplies may be derived from the Customer's LV network as long as:

- The LVAC voltage is maintained between 400/230V RMS +10%, -6% and has a frequency of 50Hz +/-1%.
- The LVAC supply is firm. The Customer must restore the LVAC supply within 6 hours, should the main LVAC supply fail, for any reason.
- At sites with embedded generation, the LVAC supply is not disconnected when the Customer's generator protection or interface protection operates.

Customers may back up the LVAC supplies using a fixed standby generator or a mobile generator. Where the Customer uses a generator to back up the main LVAC supply they must ensure it is adequately maintained, periodically tested and has a sufficient supply of fuel to maintain the LVAC supplies for as long as is required.

For connections where WPD protection systems are present at the metering substation that are considered to be critical to the security of our 66kV network, the supplementary LVAC supply is to be derived by the Customer from the WPD network.

### LVAC and Building Services Generally

The fixed electrical installation is an integral part of the substation building and it is anticipated that delivery thereof will be the responsibility of the Customer for adoption by WPD. WPD LV electrical installation work will generally be limited to the final connection of LVAC supplies to the WPD supplied Generator Constraint Panel (GCP) and where applicable, the Active Network Management (ANM) Panel. These works will involve WPD installing suitably sized cable between the relevant rotary isolator and each panel.

## L.V. Electrical Installation Generally

An indicative layout of the heating, lighting and small power requirements at metering substations is provided on our standard GCS series drawings that accompany this guide. Design/ sizing of the components that comprise the installation is to be carried out by the ICP.

The consumer unit (CCU) for WPD's control room heating/ lighting/ small power requirements is to be:

- located in the WPD control room.
  - of a metal-clad type, suitable for terminating SWA multicore cables with appropriate glanding
  - provided with a 100 amp 2 pole main switch.
  - provided with sufficient MCB ways to service the building heating, lighting and small power requirements
  - provided with further sufficient dedicated 20A single phase MCB outgoing ways for
    - 110 Volt Battery Charger Supply
    - 48V (or where required 24V) Battery Charger Supply
    - Protection & Intertripping Panel Compartment Lighting Supplies
- All of the above are to be provided with a rotary isolator in a logical position adjacent to the apparatus being served. Both battery charger circuits are to be fed by MCB's with a type D characteristic to withstand battery charger inrush currents.
- Switchgear Compartment Heater Supplies
- 
- provided with separate dedicated 5 amp MCB type D ways to feed unswitched spurs for
    - Generator Constraint Panel (GCP)
    - Active Network Management (ANM) Panel (where required as part of the connection offer)
  - Provided with a facility for future expansion as necessary

Traywork/ trunking is to be supplied and installed by the Customer/developer vertically from the consumer unit to a suitable cable trench or overhead trunking solution. Cable tray must only be used where suitable additional impact protection is offered by the cable system itself, such as SWA or SY Flex. All trunking/tray shall be formed of galvanised steel.

A PIR activated external light shall be provided above the entrance doors to afford safe approach to the building during the hours of darkness.

Emergency lighting must be provided in accordance with BS 5266 (Emergency lighting. Code of practice for the emergency escape lighting of premises) at the most recent edition, including any subsequent amendments.

The WPD control room will ideally be provided by the Customer with a dedicated external telephone line and master socket.

Where the substation location is considered to be at particular risk of unauthorised access, WPD would conventionally seek to install a CCTV system enabled for remote monitoring via our Control Centre. In order for remote monitoring to operate, a broadband data service is required.

All wiring not enclosed in overhead trunking, cable trenches or attached to tray, shall be run in galvanised conduit.

All LVAC accessories such as switches and general purpose sockets shall be of metal clad construction.

All general purpose 13A socket outlets are to be provided with RCD earth fault protection of 30mA. This may be afforded by the use of an RCBO module within the CCU protecting the circuit or by the use of RCD incorporated 13A sockets.

The electrical installation shall conform, where applicable, fully with the requirements set out in BS7671 'Requirements for Electrical Installations' (The IET wiring regulations) at the most recent edition, including any subsequent amendments. The installer should be registered as approved by a regulatory organisation such as the NICEIC ECA or Elecsa. Copies of all relevant installation certificates (including test schedules and emergency lighting certification) should be provided to WPD upon completion of the LVAC installation.

No gas/water/telecomms or any other utilities fixtures (other than those for sole WPD use) are to be located within the substation enclosure.

### **Fixed Alarm System**

The substation building shall be provided with a fixed security alarm system of Grade 3 as defined within EN50131.

The alarm system will be discrete to the WPD substation and will not extend into the metering room or customer switchroom.

The Control Panel will be located inside and near to, the main entrance to the building.

All WPD accommodation will be covered by a sufficient number dual-tech sensors that allow for complete coverage of the monitored area, giving due consideration to the position of any internal objects, structures and/or equipment that could potentially mask the Field of View (FoV) of the sensor(s). Consideration will be given the location of access and egress points and the potential for entry by breach of the fabric of the building and where necessary sensors will cross FoVs to reduce any opportunity for tamper. All access and egress points will be fitted with appropriate alarm system contacts.

The alarm system shall have a facility to present suitable volt-free contacts through which alarm activation may be relayed to our Control centre via the RTU.

The alarm should be fed via a dedicated 6 amp MCB radial circuit with an unswitched fused spur presented locally in proximity to the alarm control panel.

The alarm control panel shall be configured to be disarmed via a 4 digit key code (rather than the 6 digits normally attributed to a Grade 3 system). This is to ensure compatibility with the regional PIN codes customarily adopted across our network.

### **Heating/ Ventilation**

The control room constructed with a heating system set to provide optimum environmental conditions for the batteries and electronic equipment. The design shall:

- Show appropriate insulation levels.
- Avoid rapid variations in temperature within the switchroom.
- Minimise air exchange to the outside.

Building designs with a low thermal mass may be susceptible to large temperature swings and therefore to the generation of condensation. To minimise the risk of condensation it is generally important to ensure that ventilation is kept to the minimum required to control temperature/dissipate excessive heat. Careful selection of the building external finishes may also be required to minimise solar gain.

## 9 Substation DC Supplies

The provision of 110 Volt batteries, chargers and distribution facilities for our switchgear and likewise 48 Volt (or 24 Volt) systems to support our SCADA facilities is a contestable element of connection works.

We conventionally purchase battery systems on a term contract basis and for economies of scale, specify our systems from a relatively small number of standard configurations. For connections where the battery system is being delivered contestably, the sizing of this system will be the responsibility of the Customer; however for information we reference the most regularly used standard WPD systems for each voltage below.

This guidance document, as a whole, assumes that the connection will be provided by a single Customer for a single metering circuit breaker. Where this is not the case (for instance more complex connection arrangements where WPD protection assets are present on site that affect our broader network) supplementary provisions may be required to meet WPD criteria. This may include the provision of a 110 volt battery system with an auto-disconnect (and reconnect) facility for the loss (and return) of substation LV supplies\*.

EE SPEC 25 details our requirements for the supply of 110 Volt battery, charger and distribution systems for metering substations. A battery sizing calculator is available within this document.

EE SPEC 104 details our requirements for 48V and 24V Volt battery, charger and distribution systems. A battery sizing calculator is available, upon request, to assist the ICP in selection of SCADA battery system.

Increasingly, due to broader network considerations, we are finding ourselves needing to introduce intertripping facilities for EHV DG connections. In such cases, dedicated digital communications multiplexer standing DC loads may approach levels that exceed the capacity of certain SCADA battery systems. Multiplexer systems may result in an additional standing load of 5 amps and this should be added to other burdens in the ICP's SCADA battery system design. In circumstances where the ICP doesn't wish to carry out site-specific SCADA battery design in advance of system specification, we would be confident that a 40A 340Ah system would suffice for foreseeable connection arrangements.

Please note that dedicated DC distribution board facilities are to be provided with both the 110V and 48V (or 24V) battery systems. These are to be wall-mounted in a location in close proximity to the respective battery/ charger.

\*Such systems are often referred to as 'Black Start' enabled and are specified within EE SPEC 23. They would customarily be required at substations where otherwise a loss of battery autonomy (consequent of a sustained system incident) would prevent prompt re-energisation of supplies when desired.



## 10 SCADA RTU and Interface Cabling

The remote terminal unit (RTU) installed within a metering substation needs to be configured such that requisite status, analogue and control facilities are available at all times via our SCADA system. Due to a number of factors, including understandable security restrictions on the purchase of equipment compatible with our communications systems, the RTU must be supplied, installed and commissioned by us. For this reason, such activities are deemed to be non-contestable.

To maximise the robustness of both WPD SCADA systems and Customer data systems, no direct data link between Customer installation and the WPD RTU will be permitted, irrespective of the proposed communications protocol thereof.

The supply and installation of multipair cables between WPD equipment and the RTU could conceivably be treated as contestable, however experience suggests that it is the interests of both WPD and ICP's to have a clear demarcation in this respect. Due to the need to ensure that multipair cabling is presented and terminated in a fashion that meets the required configuration of the RTU, potential delays can be created by the required communication between DNO and ICP to achieve this. To streamline the connection process we recommend that as a default, WPD supply, install and terminate all multipair cabling between substation plant and the RTU. In order for us to do so, we would ask that ICP's present multipair terminal blocks at the plant interface in line with our standard DC schematics.

## 11 Connection Control Panel (CCP)

For all connections with an aggregate export of 500kW or above, WPD utilise a Connection Control Panel (CCP) as a common means of interfacing our broader network management system with the Customers installation. Our standard CCP is configured to cater for all foreseeable connection variants at the respective voltage level and additionally has flexibility to accommodate all foreseeable constraint management mechanisms (whether imposed by WPD and/or by National Grid). The specifics of constraint for any connection will be clearly defined within the particular connection offer for the project.

The CCP is effectively an integral part of our network management system. For this reason, we are confident that that the provision and installation of the CCP should be treated as non-contestable.

We are currently expanding formal policy guidance to cover the application of CCP's to all relevant connection types.

For any connection offers created prior to Spring 2018, the term Generator Constraint Panel (GCP) within any associated documents or drawings may be substituted with Connection Control Panel (CCP).

The WPD switchroom should be sized such that it can accommodate the CCP in addition to all other apparatus required for the connection. In order that the ICP may make sufficient provision within the switchroom at design stage, the Connection Control Panel (CCP) should be assumed to be a wall-mounted panel weighing 75kg with external dimensions of 977mm high X 800mm wide x 305mm deep. The CCP has bottom-entry cable glands and a full-sized front door hinged on the left (when viewed from the front). It needs to be located in close proximity to its associated interface panel (see over).

## 12 Connection Control Panel Interface Box

To standardise and simplify the installation, commissioning and maintenance of multicore cabling between WPD and Customer equipment we provide and install an interface box in close proximity to the associated Connection Control Panel (CCP). This approach enables us to standardise on the overall 'connection control system' for the benefit of all stakeholders.

The interface panel affords clearly identified spring screw terminals (with flip links) for the termination of requisite multicore cabling from the Customer's apparatus. It also affords a facility for interfacing digital inputs with analogue outputs, effectively ensuring the interface facility is suitable for all foreseeable connection variants that have an export capacity of 500MW or above.

The interface box could conceivably be delivered contestably by the ICP, but we have found that there are economies of sourcing CCP interface boxes in conjunction with the CCP's themselves, using our bulk purchasing power.

We are receptive to Customer proposals for an alternative multicore interface box provided that it conforms in all respects to our standard drawings (available upon request). We do not foresee that the number of such incidences will be high, but where the Customer elects to design, source and install the interface box, we will understandably not invoice the Customer for the WPD version thereof.

The WPD switchroom should be sized such that it can accommodate the CCP interface box in addition to all other apparatus required for the connection. In order that the ICP may make sufficient provision within the switchroom at design stage, the Connection Control Panel (CCP) interface box should be assumed to be a wall-mounted panel with external dimensions of 380mm high x 600mm wide x 210mm deep.

The interface box has bottom-entry cable glands and a full-sized front door hinged on the right (when viewed from the front). It needs to be located in close proximity to its associated CCP (see previous page for details), as there is a 12Vdc supply cable, and RS485 data cable connection 4metres in length (maximum) between the CCP to CCP IF Panel (which is supplied loose by WPD with the CCP/CCP Interface Panel).

We have produced standard drawings to assist ICP understanding of the termination arrangements to our standard interface panel. These are available via our website and can be identified by the prefix letters '66CCP'.

# 13 WPD Compound and Control Room Specification

## Generally

The arrangements for accommodating WPD's switchgear and the Customer's switchgear shall be determined on a project-specific basis.

It is anticipated that for an outdoor metered 66kV connection, the Customer's 66kV substation would generally be immediately adjacent to our substation compound. This would permit primary electrical connection of the substations via busbars oversailing the boundary fence between respective operational areas.

Our preferred arrangement is for separate buildings to be provided for the WPD 66kV control room and the customer switchroom. For a combined building to be suitable for partial adoption by WPD, this building should be designed and constructed such that either 'half' may be safely demolished without impairment of the function of the remaining 'half'. It should also ensure that there is clear demarcation between accommodation under WPD Safety Rules and that under Customer safety rules.

We specify that the Customer's points of automatic disconnection will be located no more than 100 metres from the WPD metering breaker in order that multicore cable intertripping, emergency break glass tripping facilities and overvoltage constraint functions remain functional under all conditions. We reserve the right to request multi-core cable volt-drop calculations from the Customer to confirm effective operation of these facilities at the upper limit of separation distance.

## Indicative WPD Control Room Designs

In an effort to assist ICP's with substation design tasks, we have produced indicative designs. These designs relate to commonly used configurations of plant and equipment and construction methods. The designs are made available by us, in electronic form, free-of-charge and Customers and ICP's are welcome to use these as a basis for their site-specific designs.

The designs include underground and overhead connected variants where appropriate

The designs currently available are detailed below:

WPD Indicative 132kV Substation Designs		
Drawing No	Title	Status
GCS0021	66kV Connection – Single Circuit Tee Off	
GCS0022	66kV Connection – Looped Connection	

## Land and Property Rights

At locations where WPD will have a separate substation area (typically a fenced off compound for 33kV, 66kV and 132kV substations) we will require the Freehold or long term Leasehold of the site (including control room/switchroom buildings), along with suitable access rights for vehicles and equipment to the site from the adjoining land.

WPD will require suitable land and access rights for any adoptable on-site cables or overhead lines. This will be in line with WPD policy and normally will be via a deed of easement.

All planning consents for substation buildings are to be obtained by the Customer.

Further information on landowner Legal Permissions and Consents, along with guidance on this for Independent Connection Providers (ICP's) and sample lease and easement documents, can be found under the Competition in Connections section of our website ([www.westernpower.co.uk/connections](http://www.westernpower.co.uk/connections))

## Vehicular Access

**Please note: the information below details general vehicular access requirement for a WPD 66kV substation. It doesn't explicitly cover the plant access requirements for any advanced works that may be required (crane access for 66kV tower modification/erection/dismantlement or specialist excavation/directional drilling equipment etc for 66kV cable works). Such requirements will have to be agreed on a project-specific basis.**

WPD will require unrestricted 24 hour access to and egress from the substation. Wherever possible, it shall be located in such a way that it avoids the need for WPD personnel to pass through any external perimeter fence/ security controls. Where present however, site access gates and the like are to be provided with a dual locking facility, incorporating a WPD substation security lock.

The substation shall be provided with an external access road / safe unloading area as follows:

- A surfaced access road between the public highway and substation compound of minimum width of 4.5m wide and designed to accept a minimum axle weight of 11 tonnes\*\*
- A minimum headroom of 4.5m along the access road\*
- A minimum internal radius on corners of 6.0m
- A minimum external radius on corners of 13.5m
- A maximum gradient of 1:15
- A maximum negotiable concave 'valley' of 48m
- A maximum negotiable convex 'crown' to avoid 'grounding out' of 76m
- A turning bay/ splay where vehicular access is only possible from one direction\*\*
- A surfaced unloading area of minimum dimensions 3.0m x 3.0m on plan directly outside the entrance doors of WPD's Control/Switch Room

The above criteria are those normally used by WPD to afford tractor/ low-loader trailer combinations access for 66kV transformer delivery. For delivery and erection of 66kV outdoor switchgear only by WPD, the above criteria may be relaxed, by agreement on a site-specific basis.

\*It should be noted that transport height restrictions will need to be identified on a project-by-project basis taking into consideration the need to maintain sufficient clearance to all structures over-sailing the haulage route (including the need to maintain sufficient clearance to all LV/HV/EHV overhead line crossings).

\*\*Both of the above are to be delivered through the provision (as a minimum) of a roadbase of engineered granular material with a suitable separation medium/ membrane from underlying sub-grade. This road-base should be suitably configured for safe access and egress, throughout all seasonal conditions, by two-wheel drive vehicles having a ground clearance of 140mm and track width of 1500mm. Failure to provide and maintain a functional vehicular access route to our substation may impair our ability to witness, commission and maintain the adoptable assets. This may have a potential attendant effect on the network connection.

## **Flood Resilience**

Unless appropriate protective measures are proposed by the Customer and agreed by WPD, all outdoor substation plant and the control room floor level shall be positioned to minimise flood risk. In practical terms, these features should be at least 500mm above the most significant foreseeable flood event. In the case of 66kV substations, the 1 in 1000 year fluvial flood level or 1 in 1000 year pluvial flood level and 1 in 200 year tidal flood level. Care shall be taken to ensure that the presence of cable ducts/ cut-out's/ entries within the substation buildings/ features do not breach any flood defences/ protective measures.

Where site topography suggests that there is a potential risk of excessive surface-water runoff under extreme weather conditions (irrespective of the findings of a formal flood risk assessment) the control room floor shall be raised 500mm above surrounding ground (and landing platform/ step details addressed accordingly). WPD apply this requirement to substation buildings due to previous experience of extreme weather events where 'flash flooding' has put network assets at risk of irreparable damage, with attendant return-to-service delays.

## **Typical Substation Compound and Fencing Specification**

- Clear site excavate and dispose of all topsoil / vegetable matter.
- Excavate / fill as necessary to reduced level subject to geotechnical data but min. 150mm below finished site level and compact sub-grade to receive compound sub-base and surfacing.
- Install compound storm / ground / surface water drainage system as necessary to effectively drain the site and prevent the unacceptable build-up of ground water or the ponding of surface water. Collect / convey discharge from drainage network to a suitable point of disposal.

- Install Terram T1000 (or similar approved) geotextile as sub-base / sub-grade separation membrane in full compliance with the manufacturer's technical recommendations.
- Lay and compact (min. 75mm thick) bed of approved, well graded hardcore / granular sub-base material.
- Lay (min. 75mm thick) bed of 20mm single size graded clean granite/ limestone chippings / aggregate, spread and levelled around concrete bases and the like.
- Install (min. 2.4m high) galvanised steel security palisade fence and gates to BS 1722 Part 12, enhanced to Western Power Distribution specification document EE SPEC 20 (copy available upon request)\*
- Form insitu concrete plant bases as required for the scheme. These shall be designed in accordance with the codes of practice relevant to the proposed structural materials and shall adequately carry and transmit to the to the natural foundation all dead, imposed and wind loads.

\*Please note that for sites where WPD assess that there is an increased risk of unauthorised access there may be a requirement for additional security measures that may include the provision of fence electrification. In these circumstances, relevant details of the supplementary fence works will be afforded to the Customer/ ICP by WPD.

### **Substation Compound Cable Access Requirements**

To assist initial installation and later modification/ extension/ development, we would, as a default, desire multicore cable runs across the site to be formed using preformed, or insitu cable troughing. This troughing should be provided with suitably rated covers for the anticipated loading conditions.

As a minimum, we would normally seek multicore trough runs to intersect any circuit breaker and VT positions.

### **WPD Control Room Sizing and Layout**

Designers should allow sufficient space to accommodate protection and control and other secondary equipment and to afford sufficient operator access and emergency egress. The control room footprints indicated on the indicative WPD drawings should provide an optimal configuration for the control room.

Door swings should be taken into account when considering minimum internal control room dimensions.

All dedicated fire escape routes within the enclosure shall be a minimum of 750mm wide.

Discrete smooth-walled cable ducting (with drawpits at logical locations) would generally be suitable for LVAC supply cabling, or comms cabling, to say compound lighting, CCTV or fence electrification systems, where these exist.

## **WPD Control Building Construction Materials**

We believe that in general a masonry-constructed building with pitched slate/ tiled roof is the best means of providing a robust, low-maintenance, vandal-resistant, stable and cost-effective environment for the switchgear. This view is based on experience of our extensive operational property portfolio.

Notwithstanding the above, we recognise that the particular characteristics of a connection may be such that the Customer, or their ICP, wishes to use a construction technique that minimises the site construction phase. This may lead to a desire to use modular or containerised steel. WPD DO NOT permit the use of GRP buildings above 11kV. WPD has extensive evidence that supports this decision where GRP buildings have leaked or are leaking providing a future operational risk to WPD staff.

We are receptive to any construction technique/ material selection proposed by the Customer, providing that these satisfy the criteria set out in this document.

## **WPD Control Room Fire Resistance/ Fire Exit Provision**

The control room enclosure shall be designed to provide a minimum fire resistance of 1 hour.

All dedicated fire escape routes within the enclosure shall be a minimum of 750mm wide.

All escape doors are to be provided with internal panic crash bar/ pad release devices.

## **WPD Control Room Durability / Moisture Resistance**

The design life of the enclosure shall, unless otherwise agreed, be a minimum of 50 years and every effort shall be made to specify materials with minimised structure / fabric maintenance requirements (although it is accepted that maintenance responsibility will rest with the Customer). It shall provide a secure, internal, dry, stable, level, clean, dust-free, non-aggressive and non-hazardous environment for WPD plant/ equipment.

The control room enclosure shall be designed in accordance with the codes of practice relevant to the proposed structural materials and shall adequately carry and transmit to the natural foundation all dead, imposed and wind loads.

The enclosure shall be designed to protect the structure and its contents from damage or risks to health and safety due to the effects of weather, water / moisture penetration and ground contaminants.

External ground / access road levels shall be designed such that there is no detrimental build-up of surface water in the proximity of the enclosure.



The substructure of the enclosure shall be tanked/ sealed/ treated to prevent water ingress. All substructure duct entries shall be sealed around cables using WPD approved products. A suitable sump shall be formed within the substructure trench area to assist with the removal of surface/ ground water during construction. A maintenance-free submersible pump with float-switch actuation shall be permanently installed within the sump, with discharge to a suitable point of disposal.

The enclosure shall be designed to adequately collect and convey surface / storm water to a suitable point of disposal.

Internal surfaces that may otherwise cause dust to propagate (masonry/ concrete etc) shall be effectively sealed by the application of appropriate paints/ sealants etc.

### **WPD Control Room Thermal Performance / Insulation**

The enclosure shall be designed to deliver a maximum target u value of  $0.45\text{W/m}^2\text{K}$ . Any risk of condensation build-up at cold-bridging points shall be mitigated. This is of particular importance on the underside of switchgear and control gear.

### **WPD Control Room Security/ Access Doors**

The enclosure shall be constructed with no areas of glazing and designed to prevent any unauthorised entry or access to the electrical plant / equipment. Appropriate safety / warning / danger signs and notices shall be permanently displayed.

All double / single leaf entrance doors shall be outward opening, of robust / vandal resistant / durable / maintenance free hardwood, steel or g.r.p. construction meeting an LPCB security rating. They shall be fitted with a secure locking arrangement (with panic exit provision) capable of receiving a Euro profile locking cylinder which will be supplied and fitted by WPD. All door hinges shall be vandal resistant / heavy duty with concealed fixings.

Double leaf entrance doors, where required, shall be designed such that the right hand leaf (viewed from outside) will open first. The meeting stiles shall be rebated / overlap or otherwise be resistant to prising. The left hand leaf shall be fixed internally by short top and bottom sliding bolts into receptors within the frame head and cill.

Heavy duty door restraints shall be fitted at the head of each door leaf and shall be capable of holding the doors open at 90 degrees.

### **Provision of Sanitary Facilities**

Over the lifetime of an outdoor metering substation it would be anticipated that frequent visits would need to be made to site by WPD staff. Similarly it is anticipated that the Customer's personnel will frequent the site during the lifetime of their connected assets. We believe that the collective frequency (and likely duration) of site access by WPD and Customer staff would be such as to justify the provision of permanent site WC and handwashing facilities. For this reason, a WC is indicated on our indicative drawings. We appreciate that the remoteness of some metering substations may present logistical difficulties for water supply. We welcome Customer/ ICP proposals in this respect.

# 14 Earthing Requirements

The earthing design shall be in accordance with *Engineering Specification EE SPEC 89*, as amended. An integrated earthing design - where the Customer earthing system is connected to the WPD substation earthing system – is normally the optimum as this gives the lowest earth impedance and hence the lowest earth potential rise, lowest touch and step voltage and lowest equipment stress voltage and allows electrode surface area requirements to be met more readily.

The WPD substation tends to be relatively small and so will normally require:

- An earth electrode loop around the substation building, 1m out, connected in duplicate to the substation earth bar.
- Multiple connections of the concrete base reinforcing bar to the earthing system.
- An earth electrode laid for all/part of the 66kV cable route to help reduce the earth impedance of the WPD substation.
- Interconnection in duplicate to the Customer earthing system.
- Customer main earthing system to be relied upon for safety<sup>1</sup>.

A consequence of the optimal integrated design is that:

- The specification of the Customer main earthing system needs to meet minimum requirements so that it can be relied upon by WPD.
- A duty of care arises from WPD to the Customer to verify that design of the Customer earthing ensures safe touch, step and transfer voltages. Note this occurs if the earth potential rise exceeds 120V for a 3s protection clearance. Consequently we ask to see safety verified for the Customer earthing system and associated metal fence.

## 13.1 Clarifications

### 13.1.1 Ratings

The following clarification on the application of EE SPEC 89 is provided with regard to earthing conductor and earth electrode ratings:

---

<sup>1</sup> NB The touch voltage at the WPD substation will vary with the soil model but may be as high as 25% of the earth potential rise; consequently the earth potential rise may have to be designed to be no more than the touch voltage limit divided by 0.25. For example with a 3s clearance time this gives  $120\text{V}/0.25 = 480\text{V}$ ; hence the need for an integrated design with a low earth impedance.

## Definition:

$I_{swgr} = 3s$  Rating of switchgear asked for (e.g. 25kA/31.5kA/40kA). NB Most are 25kA but some may be 31.5kA or 40kA if near to BSPs.

$I_{ef\ sys} = 7200A$  NB This allows temporary paralleling of 132/33kV BSP networks giving maximum of 2 x 3000A plus 20% margin for variation in earthing device ratings and covers the possible temporary solid earthing in 33kV arc suppression coil systems as solid earthing is possible but not normally used. It also allows for changes that may occur in the life of the installation.

## Requirements:

DNO earth bar to DNO Substation Perimeter Ring: 2x earthing conductor rated for 100%  $I_{swgr}$ . Duplicate fully rated connections as per ENA TS 41-24.

DNO substation perimeter ring: 60%  $I_{swgr}$  as current divides two ways.

DNO earth wire laid with cable: 70sqmm HDC 7/3.55 to BS 7884. Higher resistance assumed to ensure its 8.6kA x 3s rating is not exceeded with current division of  $I_{swgr}$ .

Interconnections from DNO earth bar to Customer earth bar/perimeter ring: 2x earthing conductor rated for 100%  $I_{swgr}$  or 1 x earthing conductor rated for 100%  $I_{swgr}$  and 33kV cable sheath earth with joints to DNO earth bar and Customer earth bar/perimeter ring verified by micro-ohmmeter to pass acceptance criteria.

Customer earthing system:  $I_{ef\ sys}$ . With perimeter ring each direction can be 60%  $I_{ef\ sys}$ . Note that the Customer earthing system would also need to consider the earth fault current within the Customer's installation (e.g. LV earth fault case).

Electrode surface area calculation in accordance with clause 7.15.5:  $I_{ef\ sys}$ .

### 14.1.2 Earth Potential Rise

The EE SPEC 89 does not specify a maximum earth potential rise but gives functional requirements in section 6.1.1. For clarity, consideration of stress voltage in relation to fence insulators, as may be required for specific fence panels to prevent transfer voltages, and any future electric fence security system leads to the requirement to limit earth potential rise to no more than 3kV, in general.

### 14.1.3 Joints

Note that bolted joints are not permitted underground by EE SPEC 89.

Note that lightning protection joints to BS EN 50164-1 are not suitable for the earthing system as they are not rated for power frequency earth fault current, only lightning impulse current.

### 14.1.4 Joints to Reinforcing Bar

Exothermically welded joints are approved for joining from copper earthing conductor to steel reinforcing bar.

#### **14.1.5 Stranded Earth Electrode**

Care is required in ordering/specifying electrode. Cases have arisen where electrode having small strand diameter which was considered insufficient for mechanical and corrosion reasons was used and had to be overlaid. The minimum accepted for WPD stranded copper earth electrode is 3mm. For Customer electrode BS 7430 now defines a minimum size of 1.7mm. See Appendix A.

Note that stranded copper earth electrode shall be hard-drawn copper to BS 7884. Soft-drawn is not suitable due to mechanical considerations and its ability to 'bird-cage' on installation.

#### **14.1.6 Materials**

Copper is approved for tape and stranded earth electrode as per EE SPEC 89. Galvanised steel is not approved for earth electrode in EE SPEC 89. Should the Customer wish to consider galvanised steel for the Customer main earth electrode then detailed corrosion assessment may be required, particularly if the safety of the WPD substation relies on it. In general, the corrosion performance of copper is much better making it suitable for most situations.

#### **14.1.7 Checklist**

In checking proposed earthing designs, WPD will use the checklist in Appendix A, as amended, as a guide to identify if the design is correct or needs revision. The list is not exhaustive. If those preparing earthing designs check against the design against the checklist before submission this may help reduce iterations/speed up approval.

## 15 Metering Equipment Accommodation

Please note that guidance on the accommodation of tariff metering equipment should generally originate from the appointed Meter Operator.

Metering equipment (meter operator equipment) shall be accommodated in a separate room or cubicle that is initially accessible to WPD, the meter operator/data collection organisations and the Customer. This room or cubicle shall be located within 10m of the WPD switchroom to keep the connections to the metering CT's and VT's as short as practicable. Access to the metering equipment shall not be via WPD's operational area.

# 16 Substation Communications Infrastructure

## Requirement for Digital Communications

WPD standard technique ST:SD1G details the requirement for digital communications with third party generator sites for the purpose of monitoring and control. It further recognises the limitations of scanning radio systems for such purposes.

This document assumes that 66kV connections will have an export capacity in excess of 1MW and as such will be likely to require a digital communication medium to our Control Centre via our broader comms network.

## Selection of Communications Medium

The selection of optimal communications medium will generally require a viability study. Upon receipt of instruction from the Customer to instigate this study, we will commission requisite desk-study work and fieldwork.

## Presumption of Microwave Communications at Connection Offer Stage

A site-specific formal connection offer will identify the cost provision that has been made for substation digital communications infrastructure and in the absence of any data to the contrary, we will initially assume that a microwave radio communications solution will be required. We will further assume that this solution would require microwave radio equipment installation at the DG site and at a WPD comms hub site. There will be exceptions to the above however and examples may include:

- Sites where additional microwave ‘relaying’ via third party comms tower/s is required due to the challenges of topography. In these instances cost estimates would need to be revised and communicated accordingly.
- Sites where resilient ‘line-of-sight’ microwave communications permit a tower (or supporting structure) significantly shorter than 15m.
- Ditto above, but sites where tower height of 15m is inadequate.
- Sites where a scheme already requires a new 33kV cable route from a DG site to a WPD substation that happens to already be fibre comms enabled. In these situations a fibre comms solution may be more cost effective than a microwave solution.

In the above instances, or other deviations from the anticipated strategy, cost estimates would need to be revised and communicated to the Customer accordingly.

## Impact of Communications Infrastructure on Customer Substation Design

At offer stage it should be assumed (unless otherwise advised) that there will be a requirement for microwave communications to be established at the DG site.

The particular microwave comms hardware requirements for any connection can only be ascertained following completion of a site-specific communications viability study. Accepting however that the Customer may wish to carry out preliminary design work in advance of indemnifying WPD for the cost of the comms viability study, they may, at their own risk, assume that microwave communications will require the following:

- Installation of at least a 15 metre high communications mast in the vicinity of the WPD switchroom
- Installation of a multiplexer within the WPD switchroom

It is important that Customer makes allowance for the former in any planning submission sought for the site and the latter in any switchroom designs.

### **Contestability of Communications Infrastructure**

Being apparatus integral to our communications network, we believe that the supply, installation and commissioning of the multiplexer/s, microwave radio dish/es and associated cabling is non-contestable and will hence be carried out by WPD SURF Telecoms. Similarly we believe that fibre optic cable supply, installation, jointing and commissioning are non-contestable.

Unless otherwise confirmed in a specific offer, we would anticipate that the following activities, associated with substation communications infrastructure, are contestable:

- Communications tower supply and installation\*
- Communications tower foundation construction\*
- Communications tower cable duct installation\*
- Communications tower earthing\*
- Fibre cable duct supply, installation and backfilling\*
- Fibre cable joint bay/ chamber civil works\*
- 48 Volt (or where applicable 24 Volt) battery charger system supply, installation and commissioning (as defined in section 8 of this document)

\*Notwithstanding the above, WPD recognise that the provision of broader site digital communications infrastructure may be a project requisite with which the Customer (or their ICP) have limited familiarity. SURF Telecoms have extensive experience in the establishment of comms towers, microwave and fibre communications links and have established relationships with delivery contractors in this respect.

To assist broad understanding of WPD requirements for digital communications infrastructure, the following information identifies the principles that would be applied by WPD Surf Telecoms in delivering such infrastructure for a Customer. Hopefully it is appreciated that detailed communications infrastructure design requirements for a particular project can only be identified once the communications viability process has been concluded.

## **Design/ Specification for Communications Towers**

WPD Surf Telecoms conventionally purchase and install triangular tubular lattice tower type structures, rather than monopole solutions.

Tower structures are designed to support the relevant telecommunications equipment at the required height. The design process includes a site-specific derivation of applied static and dynamic loads (including for example, those relating to snow/ ice and wind loading effects) and an assessment of the tower's capability to safely withstand these loads. This process would conventionally require the input of a suitably qualified/ experienced structural designer, conversant with relevant design codes/ methodologies.

## **Design/ Specification for Communications Tower Foundations**

Tower structure foundations are designed to safely transmit to ground all static and dynamic loads imparted from the communications tower itself. For a site-specific design to be concluded, particular founding conditions are evaluated. This evaluation would generally require geotechnical fieldwork, analysis and reporting.

Tower foundations are configured to accommodate sufficient multilayer D90 Ducts in accordance with WPD ST:TC3A. These ducts exit the top of the base vertically in close proximity to the tower leg position/s and enter the foundations horizontally at a minimum depth of 600mm. A 90 degree slow-radiused bend is provided for the duct transition between horizontal and vertical. As a minimum this bend shall be formed using two 45 degree duct connectors. The duct run terminates at the WPD switchroom multicore cable trench in close proximity to the multiplexer.

## **Design/ Specification for Fibre Cable Duct Installation**

Such activities are carried out in accordance with WPD ST: TC3A - Relating to the Installation of Underground Telecoms Ducts.

## **Design/ Specification for Fibre Cable Chambers**

Such activities are carried out in accordance with WPD ST: TC3B - Relating to the Installation of Telecoms Chambers.



## APPENDIX A

### EARTHING DESIGN CHECKLIST FOR 66kV CIC SITES

SUBSTATION	REF
------------	-----

OK?	ITEM	CONSIDERATIONS
	<b>Report</b>	
	Soil Wenner test data?	Provided?
	Soil data valid?	Parallel with PILC/electrode? Representative? Large enough traverse?
	Soil model valid?	Not a uniform or two-layer soil where clearly multi-layer?
	Earth resistance: DNO substation?	Provided?
	Earth resistance: DNO s/s + cable e/w?	Provided?
	Integrated earthing design?	Segregated unlikely to work.
	Earth impedance: Combined?	Provided?
	Earth Potential Rise?	Provided? Transferred voltage considered if cable connected direct to BSP? Impact of other sources of EPR considered (e.g. 400kV towers through site)?
	Earth Potential Rise minimised?	Minimised to avoid Hot classification? Minimised hot zone so far as is reasonably practicable? Below 3kV?
	Hot/Cold Classification?	Provided?
	430V/1150V 650V/1700V plot?	Provided?
	Hot Zone Plot on appropriate map?	Google image not satisfactory. Separable from main report?
	Hot Zone Plot considered combined electrode system?	Has the Customer electrode been included?
	If Hot, voltage not transferred to external LV Customers?	Existing LV PV connected to non-dedicated PMT?
	Safety voltage: limits based on WPD protection times?	
	Modelled using CDEGS?	Contours + safety voltages.
	MALT/MALZ used appropriately?	MALZ required for large systems.
	Safety voltages: DNO S/S Plot?	Plot overlaid on electrode?
	Safety voltages: DNO S/S safe?	Clearance times provided by WPD and not assumed? Compliant? If compliant with chippings check drawing shows this.
	Safety voltages: Customer safe?	Confirmation that touch & step safe? Customer installation considered? Fence considered?
	Electrode surface area calc?	Pass with 7200A for 3s?

	Drawings	
	WPD earthing conductor: rating compliant and duplicated?	WPD earth bar to WPD S/S perimeter electrode rated for $I_{swgr} = 25/31.5/40kA \times 3s$ as appropriate? Duplicate fully rated?
	WPD earthing conductor: material & dimensions for corrosion/mechanical reasons compliant?	For rating see above. Copper tape to BS 1432? Stranded HDC to BS 7884? Minimum size met ( $\geq 3mm$ thick tape, $\geq 3mm$ strand diameter)?
	Interconnection earthing conductor: rating compliant and duplicated?	WPD earth bar to Customer earth bar/perimeter ring electrode rated for $I_{swgr} = 25/31.5/40kA \times 3s$ as appropriate? Duplicate fully rated or single fully rated and parallel fully rated path via cable sheath?

	Interconnection earthing conductor: material & dimensions for corrosion/mechanical reasons compliant?	For rating see above. Copper tape to BS 1432? Stranded HDC to BS 7884? Minimum size met ( $\geq 3\text{mm}$ thick tape, $\geq 1.7\text{mm}$ strand diameter)?
	Customer earthing conductor: rating compliant?	Rated for 7200A x 3s (e.g. 70sqmm Copper)?
	Customer earthing conductor: BS 7430 compliant dimensions for corrosion/mechanical reasons?	Minimum size met (copper: $\geq 2\text{mm}$ thick tape, $\geq 1.7\text{mm}$ strand diameter & $\geq 50\text{sqmm}$ )?
	WPD earth electrode ring around WPD building?	1m out? Continuous? WPD S/S perimeter ring rated for 60% $I_{swgr}$ ? Copper tape to BS 1432? Minimum size met ( $\geq 3\text{mm}$ thick tape)?
	WPD earth electrode laid with cable?	70sqmm HDC 7/3.55 to BS 7884? Full length shown on drawing?
	Earth rods at corners of WPD earth electrode ring around WPD building?	Present? Copper-clad steel $\geq 12.5\text{mm}$ diameter to ENA TS 43-94?
	Customer earth electrode: size and material suitable?	$\geq 50\text{sqmm}$ HDC? $\geq 1.7\text{mm}$ strand diameter?
	Customer earth electrode: material suitable without detailed corrosion assessment?	Copper, not galvanised steel?
	Customer earth electrode: duplicate connections between split parts?	Where the site is physically separated (e.g. PV in multiple fields that are not adjoining), duplicate fully rated or single fully rated and parallel fully rated path via cable sheath?
	Electrode depth defined?	600mm?
	Joints approved?	Bolted are not approved underground nor for rebar. With respect to Customer electrode joints note that joints to BS EN 50164-1 (Lightning Protection Components) are not rated for power frequency current x 3s but only lightning impulse current; thus they are not suitable to be relied upon by the DNO.
	Rebar bonded?	Design report may require rebar to be bonded for touch control. Two or more bonds?
	Test pits removed?	We do not require test pits.
	Chippings?	If design report requires chippings for safety are they provided? Is type of chippings specified and compliant with our spec?
	Fence safe?	Abutting substation without insulated panel? Independently earthed but inadequate separation from electrode? Fence earthing defined?
	Insulated fence panel design?	Insulators at both ends? Suitable insulators?
	<b>CDEGS</b>	
	Files?	
	<b>Post-installation</b>	
	Test report?	Measured resistance/impedance interpreted via appropriate CDEGS software?
	Design report revised?	Hot zone updated? Still safe?

Western Power Distribution (East Midlands) plc, No2366923  
Western Power Distribution (West Midlands) plc, No3600574  
Western Power Distribution (South West) plc, No2366894  
Western Power Distribution (South Wales) plc No2366985  
Registered in England and Wales  
Registered Office: Avonbank, Feeder Road, Bristol BS2 0TB

