



Company Directive

STANDARD TECHNIQUE: TP21E/3

Provision of WPD Earth Terminals to Customer LV Installations

Summary

This Standard Technique defines requirements regarding the provision of WPD Earth Terminals to LV Customers.

Author: Graham Brewster

Implementation Date: October 2019

Approved by

Carl Ketley- Lowe
Engineering Policy Manager

Date:

14/10/2019

Target Staff Group	Network Services Teams & ICPs
Impact of Change	AMBER - The changes have an impact of current working practices that are not safety critical – Communication at next team meeting or as part of a retraining programme
Planned Assurance Checks	None

NOTE: The current version of this document is stored in the WPD Corporate Information Database. Any other copy in electronic or printed format may be out of date. Copyright © 2019 Western Power Distribution

IMPLEMENTATION PLAN

Introduction

This Standard Technique defines technical requirements regarding the provision of WPD Earth Terminals on LV supplies for connection to Customer LV Installations.

Main Changes

- Revised requirements for AC electrified railways
- New 'Railway PME Application & Assessment Form' introduced
- Minor revision to the form of words for Highways England Feeder Pillars

Impact of Changes

This document is relevant to all staff involved in the design, construction, maintenance, repair, replacement and/or removal of the WPD LV distribution system.

Implementation Actions

Managers shall ensure all relevant staff are made aware of the issue of this revised Standard Technique.

Where any difficulty is encountered in the application of this policy, the Policy Engineer - Earthing shall be notified.

Implementation Timetable

This Standard Technique shall be implemented with immediate effect.

REVISION HISTORY

Document Revision and Review Table		
Date	Comments	Author
October 2019	Issue of TP21E/3 <ul style="list-style-type: none"> • Revised requirements for AC electrified railways (4.3, 4.4 & 5.13) • New 'Railway PME Application & Assessment Form' (5.13.3 & 5.13.4) • Minor revision to the form of words for Highways England Feeder Pillars (5.18.3) 	Graham Brewster
May 2019	Issue of TP21E/2 Revised requirements for: <ul style="list-style-type: none"> • Motorway services and fuel filling stations • Street electrical fixtures and other housings accessible by the public • Electric vehicle charging points Document re-formatted and layout revised	Graham Brewster
May 2017	Page Amendment <ul style="list-style-type: none"> • References to ENA G12 updated • Revised requirements for AC electrified railways • Additional requirements for DC electrified railways included 	Graham Brewster
January 2014	<ul style="list-style-type: none"> • Implementation page added. • Page numbers amended. • Briefing document attached (Appendix G) 	Stephen Davies
October 2013	<ul style="list-style-type: none"> • New document which replaces guidance previously held in ST:TP21P 	Simon Scarbro

Contents

1.0	INTRODUCTION	7
2.0	LEGAL AND OTHER REQUIREMENTS	7
3.0	DEFINITIONS	8
3.1	Types Of Earthing System	8
3.2	Means Of Earthing	8
	3.2.1 ‘Means Of Earthing’ Provided By Customer	8
	3.2.2 ‘Means Of Earthing’ Provided By WPD	8
3.3	Definition Of Installation Types	9
4.0	GENERAL REQUIREMENTS	9
4.1	Offer Of WPD Earth Terminal	9
	4.1.1 New / Replacement LV Connection	9
	4.1.2 Existing LV Connection	9
4.2	Offer Of PME Earth Terminal (TN-C-S Earthing)	9
4.3	Installations Where A PME Earth Terminal Shall Not Be Offered	10
4.4	Installations Where The Offer Of A PME Earth Terminal Is Subject To Specific Conditions	11
4.5	Offer Of WPD SNE Earth Terminal (TN-S Earthing).....	14
4.6	Installations Where An SNE Earth Terminal (TN-S Earthing) Shall Not Be Offered	16
4.7	No Earth Terminal Offered/Used (TT Earthing).....	16
4.8	Standard Letter – Unable To Offer WPD Earth Terminal	16
4.9	Requirements Relating To Provision Of WPD Earth Terminals	17
	4.9.1 Provision Of PME Earth Terminals.....	17
	4.9.2 Provision Of WPD SNE Earth Terminals.....	18
	4.9.3 Provision Of No WPD Earth Terminal.....	19
4.10	Response To Request To Bond A Lightning Protection System To A WPD Earth Terminal.....	19
5.0	SPECIAL INSTALLATIONS WHERE THE OFFER OF A PME EARTH TERMINAL IS SUBJECT TO SPECIFIC REQUIREMENTS/LIMITATIONS	19
5.1	Caravan Parks/Camping Parks and Similar Locations.....	19
5.2	Mobile / Transportable Units	21
5.3	Exhibitions, Shows and Stands	22
5.4	Other Temporary Electrical Installations	23
5.5	Marinas and Similar Locations.....	24
5.6	Motorway Services and Similar Locations Adjacent To Fuel Filling Stations	25
5.7	Permanent Buildings at Construction Sites and Demolition Sites	25
5.8	Mines	26
5.9	Quarries	28
5.10	Sports Pavilions	29

5.11	Swimming Pools and Other Basins	29
5.12	Agricultural and Horticultural Premises	30
	5.12.1 <i>Locations Intended for Livestock</i>	30
5.13	Railway/Tramway Auxiliary LV Supplies.....	31
	5.13.1 <i>LV Supplies To Traction Supply Points On AC Electrified Railways</i>	32
	5.13.2 <i>LV Supplies To Locations Other Than Traction Supply Points On AC Electrified Railways</i>	32
	5.13.3 <i>LV Supplies Associated With Non-Electrified Railways</i>	34
	5.13.4 <i>LV Supplies Associated With DC Electrified Tramways</i>	35
	5.13.5 <i>LV Supplies To Sites With Both AC & DC Electrified Railways/Tramways</i>	36
	5.13.6 <i>Special Installations: Metallic Housings At Network Rail Intake Positions</i>	36
5.14	Supply Terminating In A Separate Permanent Structure/Building Remote from the Building It Supplies	38
5.15	Multiple Intake Positions and Multiple Connections	38
5.16	Communication Stations	39
	5.16.1 <i>Communication Stations With An Independent Earth Electrode</i>	39
	5.16.2 <i>Communication Stations On/In Other Buildings</i>	40
	5.16.3 <i>Shared Communication Station Towers</i>	40
5.17	Street Lighting/Road Signs with Required Maximum Capacity $\leq 500W$	40
	5.17.1 <i>Connection with No Distributor Network Beyond</i>	40
	5.17.2 <i>Connection to Distributor with CNE Network</i>	41
	5.17.3 <i>Connection to Distributor with SNE Network</i>	42
5.18	Street Electrical Fixtures Not Covered By Section 5.17 and Other Housings/Enclosures Accessible to the Public	43
	5.18.1 <i>Class II Construction</i>	43
	5.18.2 <i>Class I Construction</i>	44
	5.18.3 <i>Special Installations: Highways England Feeder Pillars</i>	45
5.19	Charging Points for Electric Vehicles	47
	5.19.1 <i>Highway Charging Pillars and associated Street Distribution Pillars</i>	47
	5.19.2 <i>Electric Vehicle Charging Points In Publically Accessible Spaces</i>	47
	5.19.3 <i>Electric Vehicle Charging Points At Fuel Filling Stations</i>	47
	5.19.4 <i>Other Premises Containing Electric Vehicle Charging Points</i>	48
5.20	Parallel LV Generators	48
	5.20.1 <i>Solar Photovoltaic (PV) Systems</i>	48
	5.20.2 <i>Other Parallel LV Generators</i>	49
5.21	Metalclad & Similar Buildings Presenting External Earthed Metallic Parts	49
6.0	BACKGROUND INFORMATION	50
6.1	Types Of Earthing	50
	6.1.1 <i>TN-S Earthing</i>	51
	6.1.2 <i>TN-C-S Earthing</i>	51

6.1.3	<i>TT Earthing</i>	52
6.1.4	<i>Protective Neutral Bonding</i>	52
6.2	Definitions	54
6.2.1	<i>Definition Of Types Of Earthing System</i>	54
6.2.2	<i>Definition Of Installation Types</i>	56
6.2.3	<i>Definition Of Other Terms</i>	59
6.3	Principles of Customer Installation Earthing.....	60
6.4	TN-C-S (PME)	64
6.4.1	<i>Applications</i>	64
6.4.2	<i>Conditional PME Application</i>	67
6.4.3	<i>Bonding Requirements</i>	68
6.5	TN-S (SNE) Earthing.....	70
6.5.1	<i>Applications</i>	70
6.5.2	<i>Bonding Requirements</i>	70
6.6	TT Earthing	71
6.6.1	<i>Applications</i>	72
6.6.2	<i>Residual Current Devices</i>	72
6.6.3	<i>Bonding Requirements</i>	72
6.7	Extracts From ESQC Regulations & DTI Guidance.....	72
6.8	Determination Of Minimum Earth Resistance To Prevent Customer Earthing And Bonding Conductor Exceeding Rating For Open Circuit Neutral.....	78

1.0 INTRODUCTION

This Standard Technique (ST) defines technical requirements regarding the provision of WPD Earth Terminals to LV Customers for connection to Customer LV Installations. This ST shall be read in conjunction with ST: TP21D, ST: SD6B, ST: SD5C, POL: NC4, POL: NC5 and ST: NC5A, as amended.

2.0 LEGAL AND OTHER REQUIREMENTS

The Electricity Safety, Quality and Continuity Regulations 2002 (ESQC Regulations) impose legal requirements upon WPD as a Distributor that affect the provision of a WPD Earth Terminal for connection to a customer's installation¹.

Note the following:

- a) Under ESQC Regulation 24(4) we are required to offer an earth terminal when providing a new/replacement LV connection in all cases unless we can reasonably conclude it is unsafe to do so. See POL: NC4 and ST: NC5A also.
- b) Under ESQC Regulation 25(2) we shall not give consent to making/altering a connection where we have reasonable grounds for believing that requirements of British Standard BS 7671 or the ESQC Regulations themselves are not met or where it is not safe to do so. See POL: NC4 and ST: NC5A also.
- c) Under ESQC Regulation 9(4) the connection of a 'Protective Multiple Earth (PME) Earth Terminal to metalwork in a *Caravan* or Boat is prohibited.
- d) British Standard BS 7671 defines requirements for electrical installations, including earthing. It is cited specifically by the regulatory guidance on ESQC Regulations 24(4), 25(2) and 9(4). BS 7671 defines additional situations where a PME Earth Terminal shall not be used as the Means of Earthing² or is conditional.
- e) [ENA Engineering Recommendation G12/4-1](#), as amended, provides requirements for the application of PME. G12/4-1 is referenced in the Distribution Code.

¹ The relevant Regulations are given in Section 6.76.7 together with corresponding Government Department guidance.

² Application guidance on BS 7671 is published by the Institution of Engineering and Technology (IET), formerly the IEE, as Guidance Notes. IET Guidance Note 5 cross-refers to ENA Engineering Recommendation G12/4, 'Requirements for the Application of Protective Multiple Earthing to Low Voltage Networks'.

3.0 DEFINITIONS

3.1 Types Of Earthing System

BS 7671 defines four types of earthing system:

- a) TN-S
- b) TN-C-S
- c) TT
- d) IT

These are defined in Section 6.2.1 and explained more fully in Section 6.1.

3.2 Means Of Earthing

Customer installations normally require a Means of Earthing unless they do not need to be earthed (i.e. Class II equipment). This Means of Earthing can be provided either by the customer through establishment of an independent earth electrode or via WPD through connection of the customer Main Earthing Terminal to a WPD Earth Terminal.

3.2.1 'Means Of Earthing' Provided By Customer

Where the Means of Earthing is provided by the customer through connection to an independent earth electrode³ this type of earthing system is known as TT. This may also be referred to as 'Direct' or 'RCD and Independent Earth'. This type of earthing has various applications, including those where a PME Earth Terminal is not permitted.

3.2.2 'Means Of Earthing' Provided By WPD

The Means of Earthing may be provided by connection to a WPD Earth Terminal. There are four basic methods of establishing a WPD Earth Terminal:

- a) Protective Multiple Earthing (PME) with Combined Neutral and Earth (CNE) \equiv TN-C-S
- b) Cable Sheath Earth Return with Separate Neutral and Earth (SNE) \equiv TN-S
- c) Separate Continuous Aerial Earth Wire or Split Concentric with Separate Neutral and Earth (SNE) \equiv TN-S
- d) Protective Neutral Bonding (PNB). See ST: TP21D. Depending upon whether the earth connection to the customer is taken from the transformer neutral earth or from the neutral direct this can be viewed as a form of TN-S or TN-C-S, respectively.

NOTE: The terms 'TN-S', TN-C-S and PNB are defined in Section 6.2.1 and explained more fully in Section 6.1.

³ Some pre-1966 TT installations use the water pipe as the independent earth. This was permitted by the IEE Wiring Editions from the 8th Edition – 1924 - to the 13th Edition – 1955. It has never been permitted to use gas pipes as the Means of Earthing.

3.3 Definition Of Installation Types

Installation types are defined in Section 6.2.2.

4.0 GENERAL REQUIREMENTS

4.1 Offer Of WPD Earth Terminal

4.1.1 New / Replacement LV Connection

A WPD Earth Terminal shall be offered to customers when providing a 'new LV connection'⁴ in all cases unless we can reasonably conclude it is unsafe to do so.

Where we do conclude it is unsafe to offer a WPD Earth Terminal we shall advise the customer in writing of the reason(s). A Standard Letter template is provided in Section 4.8.

4.1.2 Existing LV Connection

A WPD Earth Terminal shall be offered to customers with an existing LV connection as and when requested unless we can reasonably conclude it is unsafe to do so and provided it is technically and economically acceptable to WPD.

4.2 Offer Of PME Earth Terminal (TN-C-S Earthing)

A PME Earth Terminal is the preferred type of WPD Earth Terminal.

A PME Earth Terminal shall be offered from a PME network unless we can reasonably conclude it is unsafe to do so. It is unsafe to offer a PME Earth Terminal in the following situations:

- a) If there are reasonable grounds for believing that the customer's installation does not comply with British Standard requirements⁵. See ST: NC5A.
- b) If this would connect the PME Earth Terminal to any metalwork in a *Caravan*, Boat or other installation as given in Section 4.3. However, in certain cases, although parts of an installation may be prohibited from use of a PME Earth Terminal, other parts may not (e.g. permanent buildings at a Caravan Park) as described in Sections 4.4 and 5.0.
- c) If the WPD network does not meet the PME network requirements – see ST: TP21D.
- d) If specific requirements are not met in the case of Special Installations – see Section 5.0.

⁴ 'New LV connection' is defined as the first service or the replacement of an existing service to one or more customer's installations.

⁵ BS7671 Requirements for Electrical Installations (for consumers' installations).

The above are not exhaustive; there may be other circumstances where it is unsafe to offer a PME Earth Terminal. It may be possible to reach a local decision by consideration of similar examples from Sections 4.3 and 5.0, or reference to the principles stated in Section 6.4.2. When in doubt consult the Policy Engineer - Earthing.

4.3 Installations Where A PME Earth Terminal Shall Not Be Offered

NOTE: In certain cases, although parts of an installation may be prohibited from use of a PME Earth Terminal (e.g. Caravan or Boat) other parts may not (e.g. permanent buildings at Caravan Park, Camping Park or Marina). This section shall be read in conjunction with Sections 4.4 and 5.0.

PME shall not be offered if this would allow the connection of the PME Earth Terminal to any metalwork of the following:

- a) *Caravan*. However, see Section 5.14.4 for *Caravan Parks/Camping Parks*.
- b) *Fairground, Amusement Park* and *Circus* Temporary Electrical Installations for *Structures, Amusement Devices* and *Booths*.
- c) *Mobile Home/Residential Park Home* if specific conditions apply making it effectively equivalent to a *Caravan*. Section 5.14.4 for *Caravan Parks/Camping Parks and similar locations*
- d) *Boat, Houseboat* or *Boat Mooring Supply*. However, see Section 4.4 for *Marinas and similar locations*.
- e) *Outdoor Amenity Showers and Outdoor Amenity Facilities*.
- f) *Fuel Filling Station*. However, see Section 4.4 for *Motorway Services Premises* and similar locations adjacent to *Fuel Filling Stations*. Areas where dangerous/explosive substances are stored are treated in the same way as a *Fuel Filling Station*.
- g) *Mine Underground Shaft*. However, see Section 4.4 for *Mine permanent buildings*
- h) *Quarry Production Area*. However, see Section 4.4 for *Quarry permanent buildings*.
- i) *Construction Site or Demolition Site*. However, see Section 4.4 for *Construction Site permanent buildings*.
- j) *Multiple Occupancy Buildings*, including flats, maisonettes, bed-sits, industrial units and commercial premises in *Multiple Occupancy Buildings*. See ST: SD5C.
- k) *Shared communication towers*.
- l) *Impressed Current Cathodic Protection Systems*.

- m) Traction supply points⁶ associated with AC electrified railways. However, see Section 4.4 for LV supplies to locations other than traction supply points (i.e. train stations, signals, level crossings, point heaters and the like), and for LV supplies to non-electrified railways and to DC electrified tramways.
- n) Mobile phone base stations with antennae on HV towers. See ST: SD6E.
- o) Direct supply to a Solar PV System (i.e. solar farm).
- p) Special Installations listed in Section 4.4 and which are non-compliant with the specific requirements detailed in Section 5.0.

See Section 6.2.2 for definition of the various installation types.

Where an installation is known to be of *Class II* construction (i.e. 'double insulated' incorporating supplementary/reinforced insulation) a WPD Earth Terminal shall not be provided. Examples of street furniture that may be Class II include public telephone kiosks, pedestrian crossing bollards, parking meters and ticket machines.

Where a PME Earth Terminal cannot be offered see Sections 4.5, 4.6 and 4.7.

NOTE: In most cases where PME cannot be offered then the restrictions of Section 4.6 means that no earth terminal can be offered and the customer must employ TT earthing with their own earth electrode and RCD protection. However, where an installation has a dedicated distribution transformer it should usually be possible to provide a SNE Earth Terminal – see Section 4.5.

4.4 Installations Where The Offer Of A PME Earth Terminal Is Subject To Specific Conditions

PME can be offered, subject to specific requirements/limitations, to the following types of installation. The Specific requirements/limitations are detailed Sections 5.1 - 00. In a number of cases part of the installation is prohibited from connection to a PME Earth Terminal:

- a) *Caravan Parks/Camping Parks and similar locations*. See Section 5.1.
- b) *Mobile/Transportable Units* (e.g. outside broadcast and medical services vehicles). See Section 5.2.
- c) *Exhibitions, Shows and Stands*. See Section 5.3.
- d) Other Temporary Electrical Installations not otherwise covered above/below. See Section 5.4.
- e) *Marinas* and similar locations. See Section 5.5.
- f) *Motorway Services Premises and similar locations adjacent to Fuel Filling Stations*. See Section 5.6.
- g) Permanent buildings at Construction or Demolition Sites. See Section 5.7.

⁶ Traction supply points are the 25kV substations that provide the motive power to the electrified rail network. It includes feeder stations, auto-transformer stations, track sectioning stations (i.e. mid-point or intermediate track sectioning cabins) and any other premises which are on the same earthing system as one of the aforementioned. This is a requirement of ENA Engineering Recommendation P24.

- h) Mine permanent buildings. See Section 5.8.
- i) Quarry permanent buildings. See Section 5.9.
- j) *Sports Pavilions*. See Section 5.10.
- k) Swimming Pools or Other Basins (e.g. fountain or paddling pool). See Section 5.11.
- l) *Agricultural and Horticultural Premises*. See Section 5.12.
- m) Locations other than traction supply points on AC electrified railways (i.e. train stations, signals, level crossings, point heaters and the like), non-electrified railways, and DC electrified tramways. See Section 5.13
- n) Supply terminating in a separate permanent structure/building remote from the building it supplies. See Section 5.14.
- o) Multiple Intake Positions to a single installation. See Section 5.15.
- p) Communication Stations. See Section 5.16.
- q) Street Lighting/Road Signs with a capacity $\leq 500\text{W}$. See Section 5.17.
- r) Street *Electrical Fixtures not covered by q)* and Other Housings/Enclosures Accessible to the Public. See Section 5.18.
- s) Charging Points for Electric Vehicles. See Section 5.19.
- t) Parallel LV Generators, excluding Solar Photovoltaic (PV) Systems with a direct supply. See Section 5.20.
- u) *Metalclad* and similar buildings with external conductive metalwork. See Section 5.21.

NOTE: In some cases, to control ‘touch voltages’, it may be necessary to avoid provision of a WPD Earth Terminal for connections in the vicinity of major substations (i.e. those with the highest operating voltage of 33kV or above). This possibility is limited to major substations that are classified as ‘Hot Sites’- see reference in ST: TP21D – and then only if the difference between surface voltage and LV neutral earth voltage exceeds a particular limit. Primary System Design will advise when this condition applies.

See Section 6.2.2 for definition of installation types.

Figure 1 and Figure 2 show generic arrangements where part of the installation can be provided with a PME Earth Terminal and where that part of the installation downstream that cannot be connected to it is segregated and provided with an independent earth and suitable earth fault protection by the customer – this is referred to in this document as an ‘*Embedded TT Earthing System*’. To achieve segregation, LV system earth electrode(s) and customer independent earth electrode must not have overlapping ‘resistance areas’. Suitable hand-to-hand separation is also required above ground between bonded metalwork to avoid being able to simultaneously touch two earth zones. See ST: TP21D.

Figure 1- Separation from PME Earth Terminal at Main Distribution Board

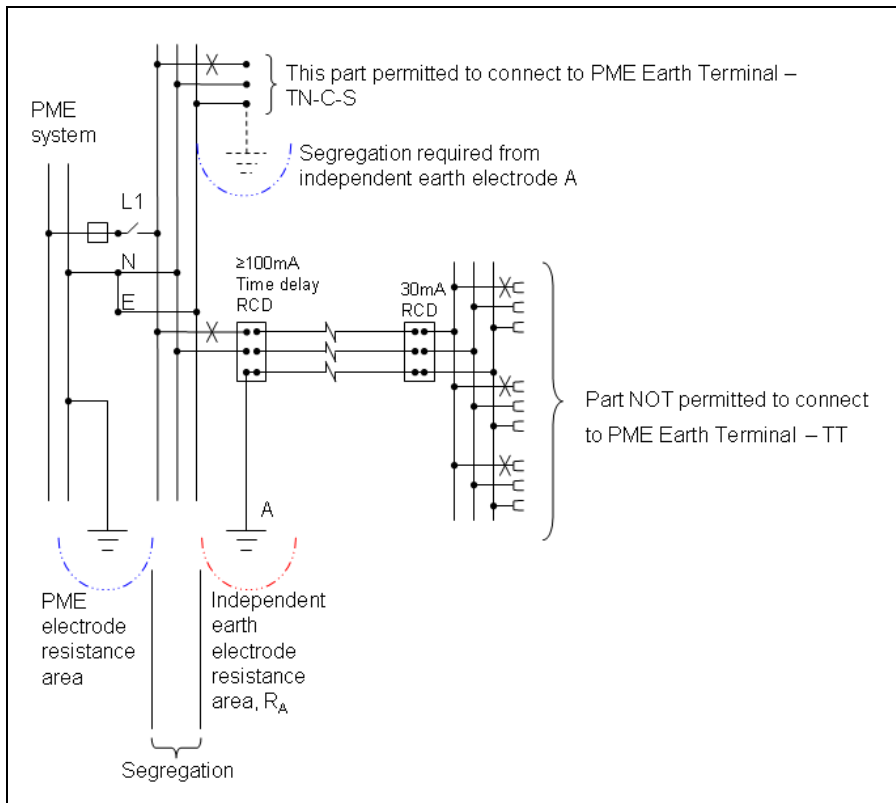

Where a PME Earth Terminal cannot be offered because compliance with the requirements is not possible (e.g. segregation is impractical as the two parts to be segregated are too close) then see Sections 4.5, 4.6 and 4.7.

NOTE: In most cases where PME cannot be offered then Section 4.6 means that no earth terminal can be offered and the customer must employ TT earthing with their own earth electrode and RCD protection. However, where an installation has a dedicated distribution transformer it should usually be possible to provide a SNE Earth Terminal – see Section 4.5.

Figure 2 – Separation from PME Earth Terminal at Remote Point

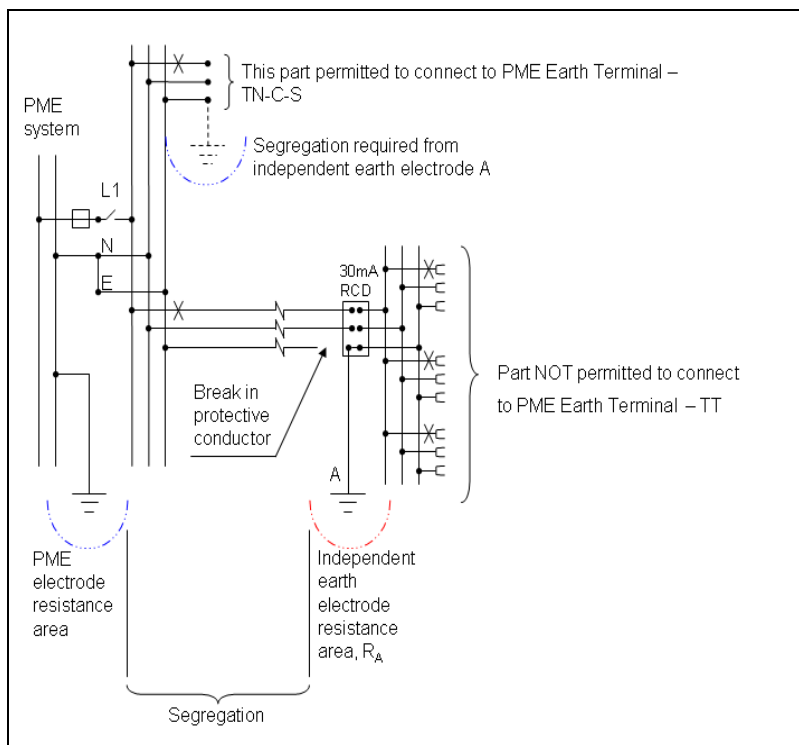

4.5 Offer Of WPD SNE Earth Terminal (TN-S Earthing)

A PME Earth Terminal is the preferred type of WPD Earth Terminal where this can be provided economically, technically and safely. Where this is not the case then a WPD SNE Earth Terminal shall be considered. A separate aerial earth wire arrangement shall only be considered in very exceptional circumstances.

A WPD SNE Earth Terminal may be offered from a TN-S earthing system unless we can reasonably conclude it is unsafe to do so and provided it is technically and economically acceptable to WPD. A WPD SNE Earth Terminal shall not be offered in the following situations:

- If the metallic path back to the neutral of the supply transformer is discontinuous/unreliable and/or, for cable, not fully bonded through.
- If the distributor contains CNE cable and the applicable conditions below are not met.
- If there are reasonable grounds for believing that the customer's installation does not comply with British Standard requirements (e.g. BS 7671 wiring regulations). See ST: NC5A.
- If there are reasonable grounds to consider that the customer has combined the neutral and earth. NB The combination of neutral and earth in the customer installation is prohibited by BS 7671 Regulation 543.4.1 and the Electricity Safety, Quality and Continuity Regulations 2002, Regulation 8(4).

In the case of Railway Electric Traction Systems with DC traction it may be necessary to employ measures to minimize the risk of electrolytic corrosion of earthing system components due to stray DC currents.

A WPD SNE Earth Terminal may be offered to a customer even though the distributor to which the customer is connected contains CNE cable or line provided that:

- a) The metallic path back to the neutral of the supply transformer is continuous and, for cable, fully bonded.
- b) They are connected to a PME earth electrode that does not exceed 20Ω , no closer to the source than the junction of the SNE service or, where present, SNE non-PME distributor and the PME distributor. See Figure 3.
- c) The service is SNE in its entirety.
- d) Apart from the service joint position, there is no connection between the neutral and the earth conductor at any point on the service or at the service position.

NOTE: The connection of the neutral to the earth within a customer's installation is prohibited by BS 7671 Regulation 543.4.1. It is the customer's responsibility to ensure compliance.

- e) The neutral and earth of the SNE service are jointed to the neutral of the CNE distributor if the SNE service joints directly to a CNE distributor.
- f) We can reasonably conclude it is safe to do so. This is covered by the above requirements and by Section 4.6.

Figure 3 - 20Ω Rule

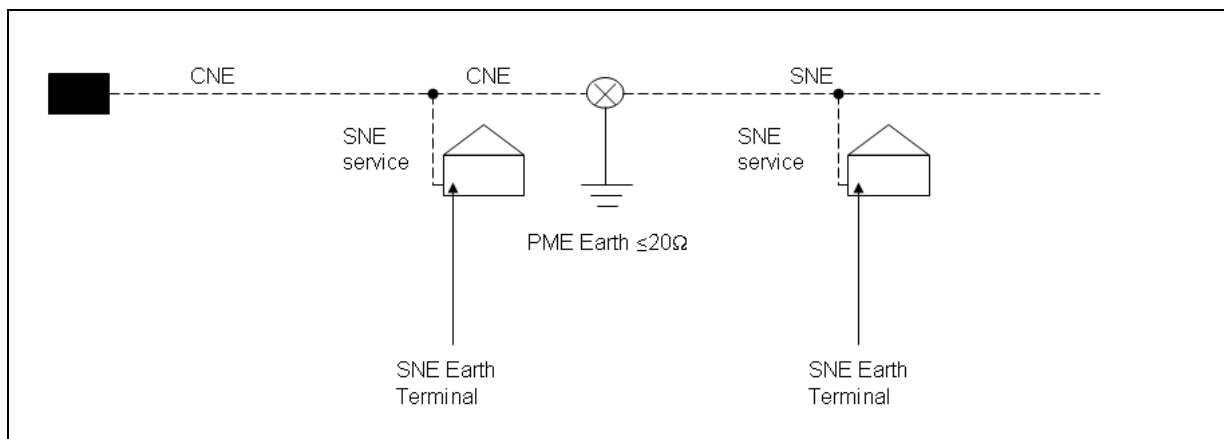

NOTE: The 20Ω earth resistance may be achieved by the lead sheath of a cable in contact with the soil or a dedicated earth electrode; 20Ω is given by approximately 8m of horizontal earth electrode or PILC/PILCSWA cable in soil with a soil resistivity of $100\Omega\text{m}$ or 30m in soil with a soil resistivity of $300\Omega\text{m}$.

4.6 Installations Where An SNE Earth Terminal (TN-S Earthing) Shall Not Be Offered

In addition to the requirements detailed above in Section 4.5, a SNE Earth Terminal shall not be offered if this would allow the connection of the SNE Earth Terminal to any metalwork of the premises/equipment listed in i) Section 4.3⁷ and ii) Section 4.4 subject to the specific requirements of that section, except where the distribution transformer is a dedicated one that will not be used to supply other customers or except where the network is SNE throughout and there is no reasonable prospect of future conversion to PME.

NOTE: In some cases, to control 'touch voltages', it may be necessary to avoid provision of a WPD Earth Terminal for connections in the vicinity of major substations (i.e. those with the highest operating voltage of 33kV or above). This possibility is limited to major substations that are classified as 'Hot Sites'- see reference in ST: TP21D – and then only if the difference between surface voltage and LV neutral earth voltage exceeds a particular limit. Primary System Design will advise when this condition applies.

Where an installation is of *Class II* construction (i.e. 'double insulated' incorporating supplementary/reinforced insulation) a WPD Earth Terminal shall normally not be provided – see Section 5.18.1.

4.7 No Earth Terminal Offered/Used (TT Earthing)

When neither a PME nor SNE Earth Terminal can be offered then no WPD Earth Terminal can be offered. Equally, a customer may, despite the offer of a WPD Earth Terminal, choose not to use it. In both cases the customer may use TT Earthing with the Means of Earthing provided by the customer through connection to an independent earth electrode and application of suitable protection. This is the responsibility of the customer.

NOTE: We should not site our LV system earth electrode(s) within the 'resistance area' of an independent earth, taken as 3.0m.

4.8 Standard Letter – Unable To Offer WPD Earth Terminal

The following standard letter has been prepared where WPD is unable to offer an earth terminal:

[\\avodcs01\Connections\Letters\Earth Terminal Letter.doc](#)

⁷ NOTE: Over time, networks are being converted to PME. By prohibiting provision of SNE Earth Terminals to premises where a PME Earth Terminal cannot be given we avoid a future unsafe situation.

The main body of the letter reads as follows:

Dear

WPD Earth Terminal - <Installation Address>

WPD is obliged to offer an earth terminal when providing a new LV connection in all cases unless we can reasonably conclude it is unsafe to do so. In this particular instance, we regret we are unable to offer an earth terminal because...

<See Sections 4.3 and 5.0 for possible reasons>

Please contact a suitably qualified electrician to make alternative arrangements; this would normally involve your electrician installing a buried 'earth electrode' and Residual Current Device (RCD). Note that effective earthing arrangements are an important safety feature of an electrical installation and so it is essential that they are established correctly.

Yours sincerely

4.9 Requirements Relating To Provision Of WPD Earth Terminals

4.9.1 Provision Of PME Earth Terminals

4.9.1.1 PME Earth Terminal Connection To Service Neutral Conductor

To provide a PME Earth Terminal the service neutral conductor shall be connected to the PME Earth Terminal in accordance with ST: CAØU.

The connection from PME Earth Terminal to service neutral conductor shall have a minimum copper-equivalent CSA of 16mm² or half the copper-equivalent CSA size of the neutral meter tail, whichever is the larger.

NOTE: For a LV cut-out with combined neutral-earth block or integral PME link the above requirement is met by virtue of the maximum neutral size possible. If a separate PME Earth Terminal connector block is used with sheath/armour connected then the above minimum size requirement shall apply to the connection from the PME Earth Terminal to the service neutral conductor.

4.9.1.2 PME Earth Terminal Connection To Cable Sheath/Armour

Where a PME Earth Terminal is provided from a SNE cable both the sheath and any armouring shall be bonded together and then connected to the PME Earth Terminal. See ST: CAØU.

4.9.1.3 PME Service Polarity

The polarity of the service shall be proved in accordance with ST: OS10F.

4.9.1.4 PME Label

A PME (TN-C-S) Label shall be provided in accordance with ST: SD5D.

4.9.1.5 PME Service Connections To PME Distributors

Figure 4 shows requirements for connecting PME services to PME mains, including Separate Neutral and Earth (SNE) circuits converted for PME.

Figure 4 – PME Service Connection Arrangements on PME Distributors

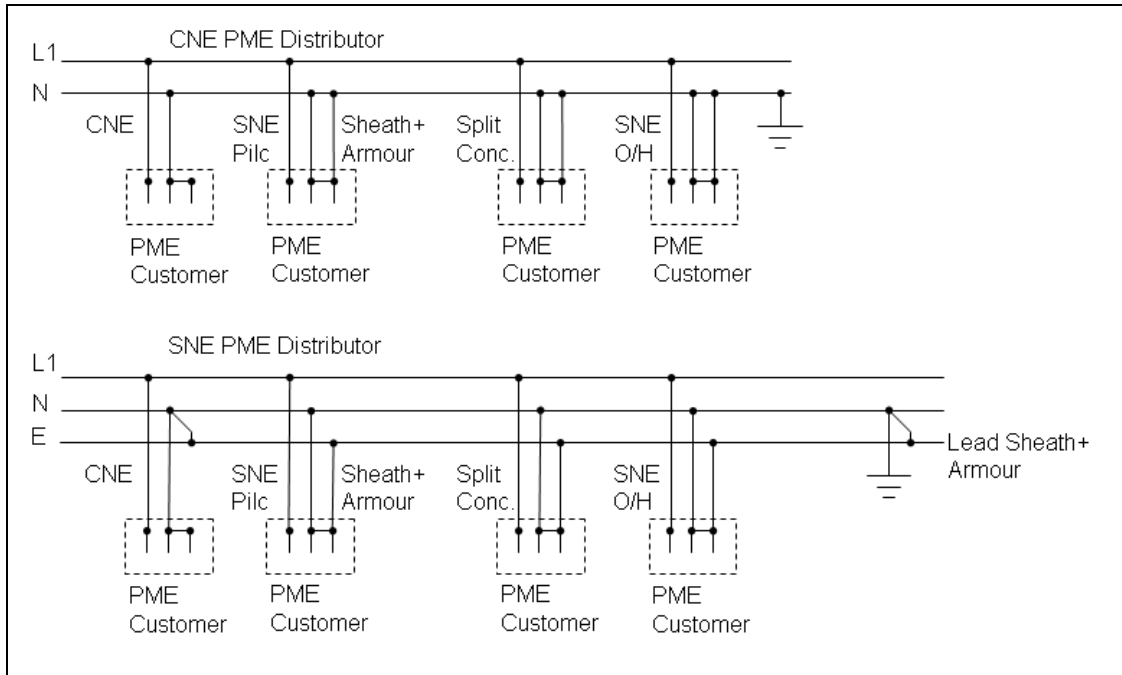

4.9.1.6 Existing Customers With SNE Earth Terminal - CNE Cable/Line In Distributor

If CNE cable/line is introduced into a distributor existing customers may retain a SNE Earth Terminal if the requirements in Section 4.5 above are met. If these requirements are not met it may be possible for such customers to convert to PME – see Section 4.2; alternatively, TT earthing may be adopted – see Section 4.7. If none of the above can be applied then conversion back to a TN-S system is a further option.

4.9.2 Provision Of WPD SNE Earth Terminals

4.9.2.1 TN-S Label

An SNE (TN-S) Label shall be provided in accordance with ST: SD5D.

4.9.3 Provision Of No WPD Earth Terminal

4.9.3.1 TT Label

A TT Label shall be provided in accordance with ST: SD5D.

4.10 Response To Request To Bond A Lightning Protection System To A WPD Earth Terminal

Customers' electrical installation designers/installers may request permission to bond a Lightning Protection System to the WPD Earth Terminal. Permission shall be granted if the earth terminal is:

- a) A SNE Earth Terminal and the network has not been converted to PME and there is no reasonable prospect of future conversion to PME.
- b) A PME Earth Terminal if the electrical installation designer/installer confirms the earthing and bonding conductors being not less than the copper equivalent cross-sectional area of the service neutral.
- c) A SNE Earth Terminal but with the associated network converted to PME if the electrical installation designer/installer confirms the earthing and bonding conductors being not less than the copper equivalent cross-sectional area of the service neutral.

Where (b) or (c) apply but the size of earthing and bonding conductors is i) not equivalent to the copper equivalent cross-sectional area of the service neutral and ii) does not meet the minimum requirements of BS 7671, then permission can be given if they confirm that earth resistance of the Lightning Protection System Earth-termination System⁸ is $>5\Omega$ at all times. Section 6.8 provides the basis for the $>5\Omega$ value; Sections 6.4.3 and 6.5.2 provide the minimum sizes of earthing and bonding conductors in accordance with BS 7671.

NOTE: The Customer's electrical installation designers/installers can be referred to Regulation 411.3.1.2 of BS 7671 and BS EN 62305.

5.0 SPECIAL INSTALLATIONS WHERE THE OFFER OF A PME EARTH TERMINAL IS SUBJECT TO SPECIFIC REQUIREMENTS/LIMITATIONS

5.1 Caravan Parks/Camping Parks and Similar Locations⁹

The ESQC Regulations 2002 specifically prohibit the connection of a PME Earth Terminal to any metalwork in a *Caravan*. This prevents a PME Earth Terminal being used for *Caravan* supplies. In accordance with Section 4.3, **PME shall not be offered for a WPD service connection direct to a *Caravan*.**

⁸ The earth-termination system is the part of an external lightning protection system which is intended to conduct and disperse lightning current into the earth.

⁹ In this section '*Caravan Parks/Camping Parks*' means '*Caravan Parks/Camping Parks and similar locations*'.

A PME Earth Terminal can be provided direct to a permanent building at a Caravan Park/Camping Park subject to the following:

- a) The service terminates at a suitable location. See ST: SD5D.
- b) The building is of a suitable type. Examples include the site owner's accommodation (NB not a *Caravan*), site office (NB not a *Caravan*), bar, restaurant, shop and entertainment complex.
- c) The general requirements in Section 4.2.

See Figure 5.

In (b) above, an indoor toilet and amenity shower block is a suitable type of building to be provided with a PME Earth Terminal if a buried earth grid is installed in the floor and if this is supplementary bonded to accessible metalwork¹⁰.

NOTE: The earth grid mitigates against the annoying perception of current through the body produced by the voltage difference that can occur between metalwork and true earth potential (e.g. through a wet concrete floor).

In (b) above, buildings with *Outdoor Amenity Showers* and *Outdoor Amenity Facilities* (e.g. outdoor dishwashing facilities) are **not** suitable types of building to be provided with a PME Earth Terminal.

NOTE: With *Outdoor Amenity Showers* and *Outdoor Amenity Facilities* it is considered that provision of an equipotential zone is not practical.

NOTE: The Customer's Electrical Installer/Designer is responsible for ensuring that the PME Earth Terminal provided for suitable permanent buildings is not connected to any *Caravan(s)* embedded within the installation. They must use an Embedded TT Earthing System.

NOTE: Where the *Caravan Park/Camping Park* toilet/amenity block electrical supply is embedded in part of a larger electrical installation provided with a PME Earth Terminal then the customer is responsible for what is connected to the PME terminal via their *Main Earthing Terminal*. They may choose to add a buried metal grid installed in the *Caravan Park/Camping Park* toilet/amenity block floor and supplementary bonded to metalwork or may use an Embedded TT Earthing System for the *Caravan Park/Camping Park* toilet/amenity block – see Section 4.2. For *Outdoor Amenity Showers* and *Outdoor Amenity Facilities* they may choose the Embedded TT Earthing System.

¹⁰ IEE Guidance Note 8 gives details of how this can be done.

Figure 5 – Caravan Park/Camping Park Connection And Earthing Arrangement

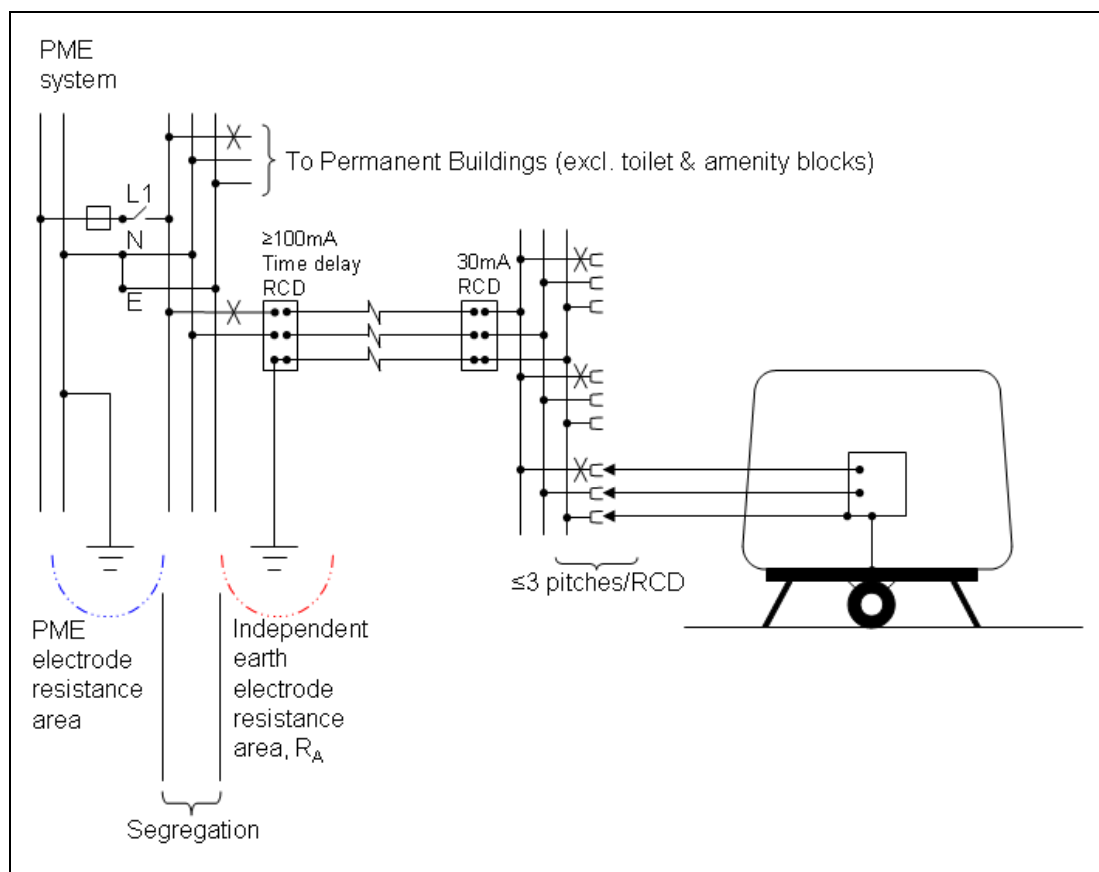

NOTE: The definition of a *Caravan* is given in Section 6.2.2 and includes *Touring Caravans* and *Motorhomes*. To cover the possibility that certain *Mobile Homes/Residential Park Homes* could fall within the scope of a *Caravan* for the purposes of the ESQC Regulations 2002 we define *Caravan* to include *Mobile Homes/Residential Park Homes* if any metalwork connected to the earth terminal is within reach of a person in contact with the general mass of earth and/or the *Mobile Home/Residential Park Home* is not permanently sited and/or not permanently connected to water or sewerage services; otherwise see Section 5.4. The definition does not include outside broadcast vehicles or other *Mobile/Transportable Units* – see Section 5.2.

NOTE: Customer’s electrical installation designers/installers can be referred to BS 7671 Section 708 and IET Guidance Notes 5 and 7.

5.2 Mobile / Transportable Units

A Mobile or Transportable Unit is defined as a vehicle and/or transportable structure in which all or part of a low voltage electrical installation is contained, which is provided with a temporary supply by means of, for example, a plug and socket outlet. Examples are outside broadcast vehicles, medical services vehicles/cabins and transportable catering units. The definition does not include Caravans, Pleasure Craft, mobile machinery and transportable generating units.

A PME Earth Terminal shall not be provided direct to Mobile/Transportable Units except if subject to exemption approved by the relevant Governmental Department (i.e. Department of Energy and Climate Change)¹¹ or as permitted by BS 7671 Regulation 717.411.4:

- a) Where the installation is continuously under the supervision of a skilled¹² or instructed person¹³, and
- b) The suitability and effectiveness of the means of earthing has been confirmed before the connection is made¹⁴ and
- c) Subject to the general requirements in 4.2.

NOTE: The requirement in (i) above is in practice not sustainable long-term and so should rarely be encountered.

NOTE: The above does not prevent a customer providing/permitting the connection of Mobile/Transportable Units to their installation; this situation is governed by the Electricity at Work Regulations 1989. It represents the situation most commonly encountered. See Sections 5.4 and 6.4.2.1.

NOTE: The Customer's electrical installation designers/installers can be referred to IET Guidance Note 7 and 8 and BS 7909.

5.3 Exhibitions, Shows and Stands

A PME Earth Terminal shall not be provided direct to *Exhibitions, Shows and Stands* except as permitted by BS 7671 Regulation 711.411.4:

Except for a part of an installation within a building, a PME earthing facility shall not be used as the means of earthing for an installation falling within the scope of this section except:

- a) Where the installation is continuously under the supervision of a skilled¹⁵ or instructed person¹⁶, and
- b) The suitability and effectiveness of the means of earthing has been confirmed before the connection is made¹⁷
- c) Subject to the general requirements in 4.2.

¹¹ There are currently no exemptions.

¹² BS 7671 defines *skilled person* as a person with technical knowledge or sufficient experience to enable him/her to avoid dangers which electricity may create.

¹³ BS 7671 defines *instructed person* as a person adequately advised or supervised by skilled persons to enable him/her to avoid dangers which electricity may create.

¹⁴ Examples of precautions taken to prevent danger arising from a broken neutral include main bonding to all incoming services and connection of earth electrodes to the customer Main Earthing Terminal.

¹⁵ BS 7671 defines *skilled person* as a person with technical knowledge or sufficient experience to enable him/her to avoid dangers which electricity may create.

¹⁶ BS 7671 defines *instructed person* as a person adequately advised or supervised by skilled persons to enable him/her to avoid dangers which electricity may create.

¹⁷ Examples of precautions taken to prevent danger arising from a broken neutral include main bonding to all incoming services and connection of earth electrodes to the customer Main Earthing Terminal.

NOTE: The above does not prevent a customer providing/permitting the connection of *Exhibitions, Shows and Stands* to their installation; this situation is governed by the Electricity at Work Regulations 1989. See Section 5.4.

5.4 Other Temporary Electrical Installations

NOTE: In most temporary supply cases PME cannot be offered and Section 4.6 means that no earth terminal can be offered and the customer must employ TT earthing with their own earth electrode and RCD protection. However, where an installation has a dedicated distribution transformer it should usually be possible to provide a SNE Earth Terminal – see Section 4.5.

This section applies to the provision of a PME Earth Terminal to other temporary electrical installations not covered by the following sections:

- a) Section 4.3: installations where a PME Earth Terminal shall not be offered.
- b) Section 5.1: *Caravan Parks/Camping Parks* and similar locations.
- c) Section 5.2: Mobile/Transport Units
- d) Section 5.3: *Exhibitions, Shows and Stands*.
- e) Section 5.5 *Marinas* and similar locations
- f) Section 5.7: Permanent buildings at Construction Sites and Demolition Sites.

Most cases will fall within the scope of the above. However, it is possible that other cases will arise that do not and will need to be considered individually. In such cases the following general guidance is given. A PME Earth Terminal can be provided to a temporary electrical installation, not otherwise covered in this Standard Technique, provided that:

- a) It is not a *Caravan, Boat, Houseboat* or Boat Mooring Supply. For example, a temporary classroom may be classed as a *Caravan* depending on its mobility – see *Mobile Home/Residential Park Home* in Section 5.1 and *Caravan* definition in Section 6.2.2.
- b) Any metalwork connected to the earth terminal is not within arm's reach¹⁸ of a person in contact with the general mass of earth. For example, a metalclad temporary building such as a containerized building may fail this criterion.
- c) The service terminates at a suitable location and is arranged in such a manner that this does not make a broken neutral more likely¹⁹.

¹⁸ Arm's reach is defined as 1.25m from a point vertically above a surface expected to be occupied by persons. The maximum vertical height above this surface from which the arm can rotate is to be taken as 1.25m giving a maximum height above the surface of 2.50m for arm's reach.

¹⁹ If mechanical stress on the cable/termination is likely through the choice of location or use of the land then a broken neutral is more likely.

- d) Bonding difficulties do not make PME inappropriate²⁰, and
- e) Subject to the general requirements in Section 4.2.

In the case of a *Mobile Home/Residential Park Home*, if it is not permanently sited and/or not permanently connected to water or sewerage services then it shall be treated as a *Caravan* because of its mobility – see Section 5.1.

Given the subjective nature of the above it is possible that difficulty will be encountered in its interpretation. In this event it is recommended that further guidance is obtained from the Policy Engineer - Earthing.

5.5 **Marinas and Similar Locations**²¹

The ESQC Regulations 2002 specifically prohibit the connection of a PME Earth Terminal to any metalwork in a Boat. This prevents a PME Earth Terminal being used for Boat Mooring Supplies. In accordance with Section 4.3, PME shall not be offered for a supply direct to a Boat, *Houseboat* or Boat Mooring Supply.

A PME Earth Terminal can be provided to a *Marina* permanent onshore building subject to the following:

- a) The service terminates at a suitable location. See ST: SD5D.
- b) The building is of a suitable type. Examples include offices, site owner's living premises (NB not a *Caravan*), workshop, bars and shops.
- c) The general requirements in Section 4.2.

In (b) above, an indoor toilet and amenity shower block is a suitable type of building to be provided with a PME Earth Terminal if a buried earth grid is installed in the floor and if this is supplementary bonded to accessible metalwork²².

NOTE: The earth grid mitigates against the annoying perception of current through the body produced by the voltage difference that can occur between metalwork and true earth potential (e.g. through a wet concrete floor).

In (b) above, buildings with *Outdoor Amenity Showers* and *Outdoor Amenity Facilities* (e.g. outdoor dishwashing facilities) are not suitable types of building to be provided with a PME Earth Terminal.

NOTE: With *Outdoor Amenity Showers* and *Outdoor Amenity Facilities* it is considered that provision of an equipotential zone is not practical.

NOTE: The Customer's Electrical Installer/Designer is responsible for ensuring that the PME Earth Terminal provided for suitable permanent buildings is not connected to any Boat, *Houseboat* or Boat Mooring Supply embedded within the installation.

²⁰ Accessibility of many extraneous conductive parts that cannot practically be bonded is an example.

²¹ In this section '*Marina*' means '*Marina* and similar locations'.

²² IEE Guidance Note 8 gives details of how this can be done.

NOTE: Where the *Marina* toilet/amenity block electrical supply is embedded in part of a larger electrical installation provided with a PME Earth Terminal then the customer is responsible for what is connected to the PME terminal via their *Main Earth Terminal*. They may choose to add a buried metal grid installed in the *Marina* toilet/amenity block floor and supplementary bonded to metalwork or may use an Embedded TT Earthing System for the *Marina* toilet/amenity block. For *Outdoor Amenity Showers* and *Outdoor Amenity Facilities* they may choose the Embedded TT Earthing System.

NOTE: The Customer's electrical installation designers/installers can be referred to BS 7671 Section 709 and IET Guidance Notes 5 and 7.

5.6 Motorway Services and Similar Locations Adjacent To Fuel Filling Stations²³

In accordance with Section 4.3, PME shall not be offered for a supply direct to the *Fuel Filling Station*.

A PME Earth Terminal can be provided for permanent buildings not associated with the *Fuel Filling Station* where they are part of a larger site (e.g. shops and restaurants at motorway services remote from the *Fuel Filling Station* area) subject to the general requirements in Section 4.2.

NOTE: The Customer's Electrical Installer/Designer is responsible for ensuring that the PME Earth Terminal provided for suitable permanent buildings is not connected to any *Fuel Filling Station* embedded within the installation.

NOTE: Customer's electrical installation designers/installers can be referred to 'Guidance for the design, construction, modification and maintenance of petrol filling stations', published by the APEA and the Institute of Petroleum and 'Electrical Installations Associated With Bulk LPG Installations' User Information Sheet 008:2010 published by UKLPG.

Where an Electric Vehicle Charging Point is to be installed at motorway services and similar locations adjacent to fuel filling stations, the requirements of Section 5.19 shall also apply.

5.7 Permanent Buildings at Construction Sites and Demolition Sites

BS 7671 states that a PME terminal shall not be used for the means of earthing for an installation at a Construction/Demolition site '*unless all extraneous-conductive-parts are reliably connected to the main earth terminal*'. It is usually impractical to comply with these bonding requirements at Construction and Demolition Sites. Note also that the ESQC Regulations 2002 prohibit the use of a PME terminal for the supply to a *Caravan*.

In accordance with Section 4.3, PME shall not be offered for a WPD service connection direct to a Construction Site or Demolition Site except to a permanent building as detailed below.

²³ *Fuel Filling Station*' means the forecourt and associated shop at a fuel dispensing installation (e.g. petroleum, diesel or LPG and also includes areas where dangerous/explosive substances are stored (e.g. bulk storage installations).

A PME Earth Terminal can be provided to a Construction Site and Demolition Site permanent building subject to the following:

- a) The service terminates at a suitable location. See ST: SD5D.
- b) The permanent building is complete and it is not to be demolished.
- c) We have no reasonable grounds to believe the installation is non-compliant with BS 7671.

NOTE: Regulation 411.3.1.2 defines the requirement for all *Extraneous-conductive-parts*²⁴ to be reliably connected to the customer *Main Earthing Terminal*.

NOTE: The customer is responsible for ensuring that earthing arrangements are suitable. For example, they would need to evaluate whether they can use a PME earth terminal if the Permanent Building is metalclad and still has scaffolding bonded to the Construction Site TT earth. BS 7375 advises 'Particular care should be taken in the case of construction sites that involve extensions to existing buildings, to ensure that extraneous- or exposed-conductive-parts in the existing building that are connected to a TN-C-S system do not come into contact with extraneous-conductive-parts or exposed-conductive-parts within the construction site. Particular care should also be taken to ensure that the ground resistance areas of any electrodes within each system do not overlap'.

- d) The general requirements in Section 4.2.

NOTE: The Customer's Electrical Installer/Designer is responsible for ensuring that the PME Earth Terminal provided for suitable permanent buildings is not connected to any Construction Site or Demolition Site embedded within the installation.

NOTE: Customer's electrical installation designers/installers can be referred to BS 7671 Section 704, IET Guidance Notes 5 and 7 and also BS 7375.

NOTE: If the site has a dedicated distribution substation that only supplies the customer it will usually be possible to provide an SNE Earth Terminal directly from the transformer neutral; this arrangement will also allow a permanent supply to be provided more easily when required. If the site does not have a dedicated distribution substation then, despite not being given an earth terminal the customer can create a TN-S supply if the customer utilizes an isolating transformer with their own segregated earth electrode.

5.8 Mines

In accordance with Section 4.3, PME shall not be offered to a Mine Underground Shaft.

²⁴ BS 7671 defines an *extraneous conductive part* as a conductive part liable to introduce a potential, generally Earth potential, and not forming part of the installation. The definition includes water installation pipes, gas installation pipes, other installation pipework/ducting, central heating/air conditioning systems, lightning protection system and exposed metallic structural parts of the building.

A PME Earth Terminal can be provided to a Mine permanent building subject to the following:

- a) The service terminates at a suitable location. See ST: SD5D.
- b) The building is of a suitable type. Examples include Mine offices and canteens.
- c) The general requirements in Section 4.2.

In (b) above, an indoor toilet and amenity shower block is a suitable type of building to be provided with a PME Earth Terminal if a buried earth grid is installed in the floor and if this is supplementary bonded to accessible metalwork²⁵.

NOTE: The earth grid mitigates against the annoying perception of current through the body produced by the voltage difference that can occur between metalwork and true earth potential (e.g. through a wet concrete floor).

In (b) above, buildings with *Outdoor Amenity Showers* and *Outdoor Amenity Facilities* are not suitable types of building to be provided with a PME Earth Terminal.

NOTE: With *Outdoor Amenity Showers* and *Outdoor Amenity Facilities* it is considered that provision of an equipotential zone is not practical.

NOTE: The Customer's Electrical Installer/Designer is responsible for ensuring that the PME Earth Terminal provided for suitable permanent buildings is not connected to any Mine Underground Shaft embedded within the installation.

NOTE: Where the Mine toilet/amenity block electrical supply is embedded in part of a larger electrical installation provided with a PME Earth Terminal then the customer is responsible for what is connected to the PME terminal via their *Main Earth Terminal*. They may choose to add a buried metal grid installed in the Mine toilet/amenity block floor and supplementary bonded to metalwork or may use an Embedded TT Earthing System for the Mine toilet/amenity block. For *Outdoor Amenity Showers* and *Outdoor Amenity Facilities* they may choose the Embedded TT Earthing System.

NOTE Customer's electrical installation designers/installers can be referred to HSE Publication 'The use of electricity in mines – Electricity at Work Regulations 1989, Approved Code of Practice L128'.

²⁵ IEE Guidance Note 8 gives details of how this can be done.

5.9 Quarries

In accordance with Section 4.3, PME shall not be offered to a Quarry Production Area.

A PME Earth Terminal can be provided to a Quarry permanent building subject to the following:

- a) The service terminates at a suitable location. See ST: SD5D.
- b) The building is of a suitable type. Examples include Quarry offices and canteens.
- c) The general requirements in Section 4.2.

In (b) above, an indoor toilet and amenity shower block is a suitable type of building to be provided with a PME Earth Terminal if a buried earth grid is installed in the floor and if this is supplementary bonded to accessible metalwork²⁶.

NOTE: The earth grid mitigates against the annoying perception of current through the body produced by the voltage difference that can occur between metalwork and true earth potential (e.g. through a wet concrete floor).

In (b) above, buildings with *Outdoor Amenity Showers* and *Outdoor Amenity Facilities* are not suitable types of building to be provided with a PME Earth Terminal.

NOTE: With *Outdoor Amenity Showers* and *Outdoor Amenity Facilities* it is considered that provision of an equipotential zone is not practical.

NOTE: The Customer's Electrical Installer/Designer is responsible for ensuring that the PME Earth Terminal provided for suitable permanent buildings is not connected to any Quarry Production Area embedded within the installation.

NOTE: Where the Quarry toilet/amenity block electrical supply is embedded in part of a larger electrical installation provided with a PME Earth Terminal then the customer is responsible for what is connected to the PME terminal via their *Main Earth Terminal*. They may choose to add a buried metal grid installed in the Quarry toilet/amenity block floor and supplementary bonded to metalwork or may use an Embedded TT Earthing System for the Quarry toilet/amenity block. For *Outdoor Amenity Showers and Outdoor Amenity Facilities* they may choose the Embedded TT Earthing System.

NOTE: The Customer's electrical installation designers/installers can be referred to HSE Publication 'Health and Safety at Quarries – Quarries Regulations 1999, Approved Code of Practice L118'.

²⁶ IET Guidance Note 8 gives details of how this can be done.

5.10 Sports Pavilions

A PME Earth Terminal can be provided direct to a *Sports Pavilion* with a shower area with floor introducing true earth potential (e.g. concrete floor) subject to:

- a) There being an earth grid in the shower area floor with the grid supplementary bonded²⁷ to accessible metalwork (e.g. pipes), and
- b) The general requirements in Section 4.2.

A PME Earth terminal can be provided direct to a *Sports Pavilion* without a shower area.

NOTE: The Customer's electrical installation designers/installers can be referred to IET Guidance Note 5.

5.11 Swimming Pools and Other Basins²⁸

A PME Earth Terminal can be provided direct to a Swimming Pool installation subject to the following:

- a) There being an earth grid in the poolside area²⁹ and shower area with the grid supplementary bonded to accessible metalwork³⁰.
- b) The general requirements in Section 4.2.

NOTE: An additional earth electrode is recommended by BS 7671³¹ to help control touch voltage for a broken neutral.

NOTE: Where the Swimming Pool electrical supply is embedded in part of a larger electrical installation provided with a PME Earth Terminal (e.g. leisure centre or house/hotel with a pool) the customer's electrical installation designer/installer is responsible for what is connected to the PME Earth Terminal via their *Main Earth Terminal*. They may choose to add a buried earth grid to the poolside and shower area, supplementary bonded to accessible metalwork or may use an Embedded TT Earth System for those areas. However, with regard to the Embedded TT Earth System this may be practical for an outside pool or separate building but not an indoor one unless the whole installation uses TT earthing – simultaneous inaccessibility must be maintained between the two earth zones.

²⁷ Supplementary equipotential bonding conductors are used to supplement fault protection by maintaining various exposed conductive parts and extraneous-conductive-parts at substantially the same potential, such as the connection of all exposed-conductive-parts and extraneous-conductive-parts that can be touched by livestock in an agricultural installation.

²⁸ In this section "*other basins*" means the basins of fountains and of paddling pools.

²⁹ This is BS 7671 Zone 1 and Zone 2 which is the poolside zone from the pool/basin rim out to 3.5m from the pool/basin rim.

³⁰ Accessible metalwork can include exposed structural steelwork, metal pipes, metal hand rails and metal diving boards. The grid helps control discernible touch voltage due to neutral voltage drop caused by load current.

³¹ BS 7671 section 702.410.3.4.3 Zone 2, Para. 1 (ii), Note recommends that an earth electrode of suitably low earth resistance (e.g. 20 ohms) be installed and connected to the protective equipotential bonding. IEE Guidance Note 5 section 14.5 provides guidance.

NOTE: The Customer's electrical installation designers/installers can be referred to BS 7671 Section 702 and IET Guidance Notes 5, 7 and 8. IET Guidance Note 8 states 'The magnitude of the current through the human body which is discernible varies from person to person but it is generally accepted that perception of electric current can occur from 0.5mA. With this in mind, the installation designer may decide that the swimming pool installation should form part of a TT system rather than make use of the electricity distributor's earthing facility. In other words, the installation would be earthed to an installation earth electrode rather than to the supply earthing terminal. This may overcome a possible problem with discernible voltages associated in the supply neutral transmitted to the extraneous-conductive-parts of the installation'.

5.12 Agricultural and Horticultural Premises

NOTE: BS 7671 defines additional requirements which are detailed in BS 7671 Section 705 (i.e. supplementary bonding, additional protection and RCD protection). Supplementary bonding is required in locations where livestock can touch *Exposed-conductive-parts* and *Extraneous-conductive-parts*; this includes any metal grid in the floor if installed and *Extraneous-conductive-parts* in, or on, a floor (e.g. reinforced concrete). Dwellings within the *Agricultural* and *Horticultural Premises*, intended solely for human habitation, are excluded from the scope of Section 705.

A PME Earth Terminal can be provided to *Agricultural* and *Horticultural Premises* that do not contain locations intended for livestock subject to the following:

- a) The service terminates at a suitable location. See ST: SD5D.
- b) The general requirements in Section 4.2.

NOTE: Where PME is provided and there are remote farm buildings then the customer is responsible for the earthing arrangements at these buildings. If all *Extraneous-conductive-parts* cannot be bonded to the PME Earth Terminal then they may choose that the pipes and metalwork of such remote buildings, whether or not they have an electricity supply, are segregated from the PME Earthing System; if the customer gives an electricity supply to such buildings then this would need to be an Embedded TT Earthing System.

For premises that do contain locations intended for livestock see Section 5.12.1 for further requirements.

NOTE: The Customer's electrical installation designers/installers can be referred to BS 7671 Section 705 and IET Guidance Notes 5 and 7.

5.12.1 Locations Intended for Livestock

NOTE: BS 7671 defines additional requirements for locations intended for livestock which are detailed in BS 7671 Section 705.415.2.1. Supplementary bonding is required in locations where livestock can touch *Exposed-conductive-parts* and *Extraneous-conductive-parts*. This includes any metal grid in the floor if installed and *Extraneous-conductive-parts* in, or on, a floor (e.g. reinforced concrete). BS 7671 also states 'unless a metal grid is laid in the floor, the use of a PME earthing facility as the means of earthing for the electrical installation is not recommended'.

NOTE: Livestock are sensitive to small potential differences and may perceive the flow of low level current due to voltage imported from the PME Earth Terminal.

A PME Earth Terminal can be provided direct to premises intended for livestock (e.g. direct into a milking parlour, cattle shed etc) subject to the following:

- a) The service terminates within a permanent structure/building.
- b) There being an earth grid in the floor of any location intended for livestock with the grid supplementary bonded to accessible metalwork.
- c) The general requirements in Section 4.2.

NOTE: In practice this means that in the case of a larger installation where the supply is not direct into the milking parlour/cattle shed etc that PME can be provided and the customer's electrical installation designer/installer, responsible for the decisions regarding how to provide earthing within the installation:

- May use the PME Earth Terminal to earth the farmhouse/office/shop etc.
- May use the PME Earth Terminal to earth the farm livestock buildings where a metal grid is installed in the floor supplementary bonded to accessible metalwork.
- May use an Embedded TT Earthing System where the full bonding requirements of BS 7671 cannot be met.
- May decide not to use the PME Earth Terminal but only TT earthing.
- Should, in accordance with IET Guidance Notes 5 and 7 to BS 7671, advise the customer that if PME is to be used in the locations intended for livestock and the metal grid in the concrete floor cannot be bonded or does not exist, the small voltage differences referred to above may adversely affect livestock feeding and milking.

NOTE: The Customer's electrical installation designers/installers can be referred to BS 7671 Section 705.415.2.1 and IET Guidance Note 5 and 7.

5.13 **Railway/Tramway Auxiliary LV Supplies**

For the purpose of this section the following definitions apply:

- "Railway Infrastructure Manager" means the body or undertaking that is responsible for establishing and maintaining railway infrastructure. It includes (amongst others) Network Rail and HS2 Ltd.
- "Tramway Infrastructure Manager" means the body or undertaking that is responsible for establishing and maintaining tramway infrastructure. It includes (amongst others) Nottingham Express Tram, Midland Metro and Sheffield Supertram.

5.13.1 LV Supplies To Traction Supply Points On AC Electrified Railways

In accordance with Section 4.3, a PME Earth Terminal shall not be offered on an LV supply to traction supply point on an AC electrified railway.

Traction supply points are the 25kV substations that provide the motive power to the electrified rail network. It includes feeder stations, auto-transformer stations, track sectioning stations (i.e. mid-point or intermediate track sectioning cabins), and any other premises which are on the same earthing system as one of the aforementioned.

The requirements for auxiliary LV supplies at traction supply points for AC systems are set out in ENA Engineering Recommendation P24. The provision of an earth terminal is prohibited because of the high traction return currents flowing through earth paths.

5.13.2 LV Supplies To Locations Other Than Traction Supply Points On AC Electrified Railways

ENA Engineering Recommendation G12/4-1 permits the provision of a PME Earth Terminal for auxiliary LV supplies on an AC electrified railway at locations other than traction supply point substations, such as train stations, signals, level crossings, points heaters and the like, subject to certain conditions being satisfied.

However, following an incident on its LV network, WPD requires additional conditions to be satisfied before the provision of a PME earth terminal is permitted at these locations.

A PME Earth Terminal can be provided on LV supplies to locations other than traction supply points on AC electrified railways subject to the following:

- a) The installation must comply with the requirements of BS 7671, including equipotential bonding under PME conditions.
- b) The housing at the intake position must not expose Meter Operator, WPD staff/contractors, Railway Infrastructure Manager staff/contractors or members of the public to dangerous touch potentials.
- c) Metal housings containing LV equipment should not be employed at the intake position or elsewhere on the installation unless exposure to dangerous touch potentials³² is suitably controlled. It is the responsibility of the Railway Infrastructure Manager to assess and control such risks.

Note: Network Rail has been given a temporary dispensation by the ENA to enable them to use metallic enclosures at the intake position provided particular earthing requirements have been satisfied - see Section 5.13.6 for further details.

³² Dangerous touch potentials may be present in the event of an open-circuit fault in a combined neutral and earth (PEN) conductor of the WPD low voltage network supplying the installation

- d) A bonding conductor shall be provided between the PME earth terminal and the traction return circuit where the LV equipment being supplied, or its associated exposed conductive parts, is at risk of contact with the traction supply³³. The bonding conductor shall have sufficient cross-sectional area so that it will not be overheated by the portion of traction return/short circuit current which can flow in it. If this current exceeds the LV service cable rating then no such bond shall be made and a PME Earth Terminal shall not be provided.
- e) Under the normal feeding arrangement ³⁴ and any alternative / emergency traction feeding arrangement ³⁵, the 25kV feeder stations supplying the section of track associated with the LV supply shall satisfy the following requirement:
- The 25kV feeder stations shall be equipped with traction return system connections³⁶ in accordance with NR/SP/ELP/21085³⁷ and PAN/E&P-E/EE/ESD/0102³⁸. In other words:
 - Duplicate trackside spider plates, one located on each side of the track
 - Duplicate and diversely routed traction return bonds between the return current busbar and each trackside spider plate, each rated for 100% operational load plus fault current.
 - Duplicate track to spider plate bonds, one to each spider plate, each rated for 100% of the track current.

Note that this requirement still applies if the Railway Infrastructure Manager is a party other than Network Rail, for example, HS2.

- The galvanic compatibility of the components which make up the traction return system connections at the 25kV feeder stations (i.e. conductors, lugs, spider plates, rails etc) shall be verified in order to mitigate against failure of the return current connections due to interactions between dissimilar metals.
- The traction return system connections at the 25kV feeder stations shall be inspected at least every 3 months by the Railway Infrastructure Manager.
- The 25kV feeder stations:

³³ There is a risk where the equipment is located within the overhead contact line zone (i.e. zone whose limit is not exceeded by a broken 25kV overhead conductor/catenary) or within the current collector zone (i.e. zone whose limit is not exceeded by a broken pantograph on a locomotive).

³⁴ Normal feeding arrangement means without any planned or unplanned interruptions in the continuity of the AC traction supply

³⁵ Alternative / emergency feeding arrangement means where there has been loss of supply from the normal feeder station and the AC traction demand is being met from an adjacent feeder station

³⁶ In the rail industry these bonds are normally referred to as “red bonds”

³⁷ Network Rail Specification NR/SP/ELP/21085 Issue E3: Specification for the design of earthing and bonding systems for 25kV a.c. electrified lines.

³⁸ Network Rail Project Advice Note PAN/E&P-E/EE/ESD/0102 Issue 3: Earthing and bonding for AC electrification schemes applying common bonding.

- Shall be equipped with permanently installed protective devices which detect complete loss of the traction return system connections (red bonds) and initiate a trip, or
- Shall be equipped with permanently installed devices which monitor the current carrying ability of the traction return system connections (red bonds) and initiate an alarm where this capability has been compromised, or
- Have been subjected to short-term monitoring / measurement of the currents in the traction return system connections (red bonds) in order to verify their integrity / current carrying ability

Note that the short-term monitoring / measurement is a transitional arrangement whilst the Railway Infrastructure Manager develops, specifies and procures permanently installed protective and/or monitoring devices. It expires on 31/12/2020.

- The earth potential rise during traction fault conditions shall not exceed 645V and shall persist for less than 200ms.
- The rise of voltage on the traction rail due to traction return current shall not exceed 25V under frequent traction peak starting or running current conditions.

f) The general requirements in Section 4.2.

g) The other relevant requirements such as Sections 5.15 and 5.18.

To enable a request for a PME Earth Terminal associated with a railway installation to be correctly assessed, the Railway Infrastructure Manager is required to complete a [Railway PME Application & Assessment Form](#). WPD will use the flow chart at the end of the form to assess the application.

5.13.3 LV Supplies Associated With Non-Electrified Railways

A PME Earth Terminal can be provided on LV supplies to non-electrified railways subject to the following:

- a) The installation must comply with the requirements of BS 7671, including equipotential bonding under PME conditions.
- b) The housing at the intake position must not expose Meter Operator, WPD or Railway Infrastructure Manager staff/contractors or members of the public to dangerous touch potentials.
- c) Metal housings containing LV equipment should not be employed at the intake position or elsewhere on the installation unless exposure to dangerous touch potentials³⁹ is suitably controlled. It is the responsibility of the Railway Infrastructure Manager to assess and control such risks.

³⁹ Dangerous touch potentials may be present in the event of an open-circuit fault in a combined neutral and earth (PEN) conductor of the WPD low voltage network supplying the installation

Note: Network Rail has been given a temporary dispensation by the ENA to enable them to use metallic enclosures at the intake position provided particular earthing requirements have been satisfied - see Section 5.13.6 for further details.

- d) The general requirements in Section 4.2.
- e) The other relevant requirements such as Sections 5.15 and 5.18.

To enable a request for a PME Earth Terminal associated with a railway installation to be correctly assessed, the Railway Infrastructure Manager is required to complete a [Railway PME Application & Assessment Form](#). WPD will use the flow chart at the end of the form to assess the application.

5.13.4 LV Supplies Associated With DC Electrified Tramways

A PME Earth Terminal can be provided on LV supplies to DC electrified tramways, such as stations, trackside cubicles, other premises and the like, subject to the following:

NOTE: ENA Engineering Technical Report 123 provides guidelines for managing the interfaces between utility services and light rapid transit systems.

- a) ENA ER G12/4-1 section 6.2.1.1:

All installations must comply with the requirements of BS 7671, including equipotential bonding under PME conditions.

The housing at the intake position must not expose Meter Operator, WPD staff/contractors, Tramway Infrastructure Manager staff/contractors, or members of the public to dangerous touch potentials.

Metal housings containing LV equipment should not be employed at the intake position or elsewhere on the installation unless exposure to dangerous touch potentials⁴⁰ is suitably controlled. It is the responsibility of the Tramway Infrastructure Manager to assess and control such risks.

- b) ENA ER G12/4-1 section 6.2.1.3:

The traction current supply (3rd rail or overhead catenary) and return (running rails and/or 4th rail) rails are insulated from earth in accordance with the requirements of BS EN 50122-2.

Neither pole of the DC traction supply is directly connected to earth.

Any connection to earth is solely for the purpose of detecting earth fault conditions.

The LV supply, including the protective earthing conductor, and all earthed metalwork associated with it is segregated from all DC conductors by the maximum practicable distance, subject to a minimum distance of 1m in accordance with BS EN 50122-2.

⁴⁰ Dangerous touch potentials may be present in the event of an open-circuit fault in a combined neutral and earth (PEN) conductor of the WPD low voltage network supplying the installation

In the event that the Tramway Infrastructure Manager detects any corrosion due to stray DC current on any of their equipment they must advise WPD immediately.

The above requirements are necessary in order to minimize the risk of electrolytic corrosion of earthing systems due to stray DC current. They are based on a recognition that, if stray current exists, there will be paths electrically closer to the traction system which will take larger stray current than will flow through the WPD LV earthing system. In this case corrosion of cable sheaths, structures and earthing systems, which are subject to regular inspections, will quickly become apparent to the Tramway Infrastructure Manager.

These measures will also ensure that for PME systems no external voltage will be impressed on the neutral/earth conductor.

These requirements are also applicable to LV supplies using SNE service cables.

- c) The general requirements in Section 4.2.
- d) The other relevant requirements such as Sections 5.16.1 and 5.18.

NOTE: The Customer's Electrical Installer/Designer is responsible for ensuring that the PME Earth Terminal is not connected to any DC traction rails embedded within the installation.

5.13.5 LV Supplies To Sites With Both AC & DC Electrified Railways/Tramways

A PME Earth Terminal can be provided on LV supplies to sites with both AC & DC electrified railways/tramways subject to the following:

- a) The AC and DC systems are fully segregated such that there is no earth connection or sections of transfer track⁴¹ between the AC and DC systems.
- b) The requirements for LV supplies to AC traction systems (Sections 5.13.1 & 5.13.2) are satisfied.
- c) The requirements for LV supplies to DC traction systems (Section 5.13.4) are satisfied.

5.13.6 Special Installations: Metallic Housings At Network Rail Intake Positions

Where intake housings are of Class I construction then the rules for Class I Street Electrical Fixtures as described in Section 5.18.2 should preferably be applied. However, it is recognised there are some applications where this approach is not practicable.

⁴¹ A transfer track is a section of track that connects a section of track with an AC supply to a section of track with a DC supply.

Network Rail has been given a temporary dispensation by the ENA to enable them to use metallic enclosures at the intake position provided the requirements detailed below are applied:

- The housing shall not expose Meter Operator, WPD staff/contractors, Network Rail staff/contractors, or members of the public to dangerous touch potentials.
- The housing shall be surrounded by a 70mm² bare copper conductor grading electrode buried at a minimum depth of approx. 450mm and located approximately 1500mm away from all sides of the housing.
- The housing and the grading electrode shall be connected to the earth terminal.
- The housing shall have an above ground separation of at least 2m to other earthed metalwork not connected to the same earth in order to avoid touch potential risks arising from inadvertent contact between the housing and the other earthed metalwork.

Network Rail has an approved earthing design for metallic cabinets as shown in Figure 6 which shall be employed at all of their applicable sites.

Figure 6: Metallic Housing Earthing Arrangements At Network Rail Intake Positions

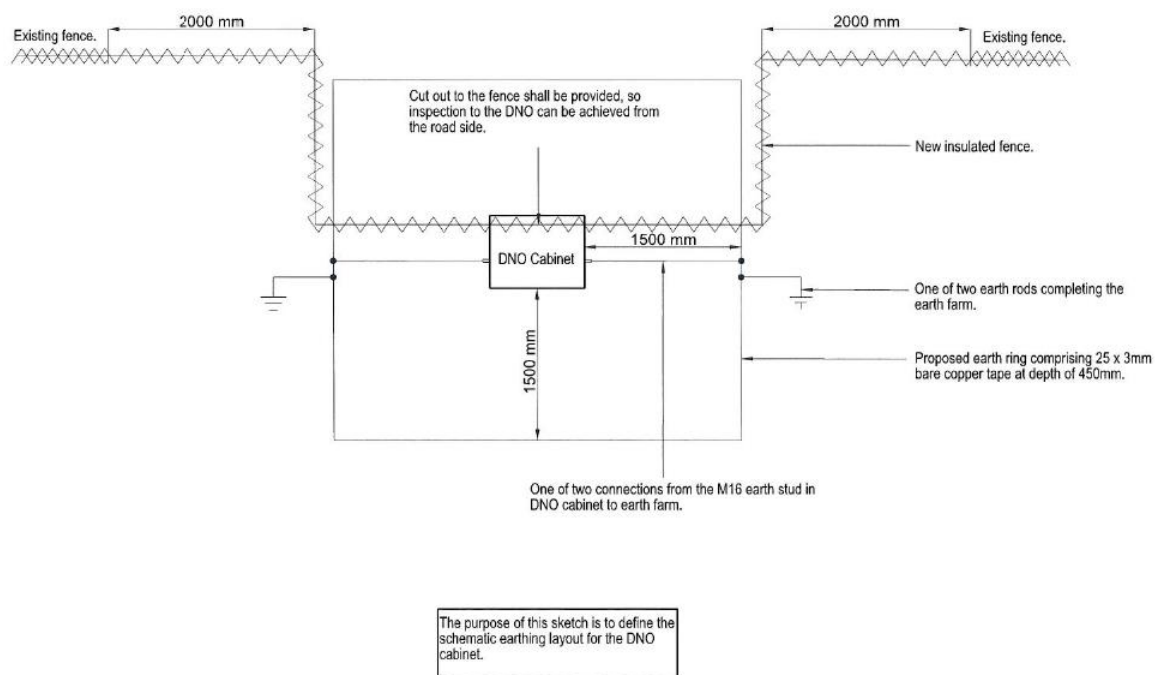

5.14 **Supply Terminating In A Separate Permanent Structure/Building Remote from the Building It Supplies**

A PME Earth Terminal can be provided to a position remote from the premises it supplies⁴² subject to the following:

- a) The service terminates at a suitable location. See ST: SD5D.
- b) The general requirements in Section 4.2 and the requirements of Sections 4.3 and 5.0. Note that within Section 5.0 there are a variety of situations where we may be asked to provide a supply terminating in a separate structure/building and so those requirements also apply.

NOTE: The customer's electrical installation designer/installer has to ensure that bonding in the remote building and protective conductor connecting between *Main Earthing Terminal* and remote Earth Terminal is related to the neutral cross-sectional area of the WPD incoming service - see Section 0.

NOTE: The Customer's electrical installation designers/installers can be referred to Regulation 544.1.1 and Table 54.8 of BS 7671 and IET Guidance Notes 5 and 8.

5.15 **Multiple Intake Positions and Multiple Connections**

NOTE: Refer also to ST: SD5C for cut-out and distribution board arrangements.

This section is limited in scope to customers connected to the WPD LV network.

For *Multiple Occupancy Buildings* see ST: SD5C. In accordance with Section 4.3, PME shall not be offered to *Multiple Occupancy Buildings*, nor to the customers within. This covers various scenarios with more than one customer in a single building structure, including flats, maisonettes, bedsits, industrial units and commercial premises (e.g. shopping centres) plus shared communication towers, all where they have communal areas. Residential premises that do not have a communal area (e.g. semi-detached and terraced houses are excluded).

For a single occupancy building (i.e. a single customer in a single building structure), in general, only a single intake position with a single connection shall be given where the connection is at LV.

NOTE: Any request for a second LV connection for safety services (e.g. fire-fighting shafts and lifts) shall be strongly resisted and the customer advised to install an automatically started generator (in accordance with BS 5588 Part 5). The customer shall be advised that provision of a second supply does not guarantee security as it cannot be assumed the second supply will always be available during faults on the HV distribution system and further that the size of such a second supply (i.e. specifically its earthing conductor) would have to match that of the first for safety reasons.

⁴² Examples of such situations include industrial/commercial facilities with two or more separate buildings and underground car parks where the service terminates at the perimeter of the installation.

NOTE: In other cases (e.g. the standby LV service is for security of supply not including safety services) then this shall also be resisted and the customer advised to install an automatically started generator. The customer shall be advised that provision of a second supply does not guarantee security as it cannot be assumed the second supply will always be available during faults on the HV distribution system. Note also that with such an arrangement the customer must consider requirements concerning isolation; customer's electrical installation designers/installers must consider Regulation 537.1.6 of BS 7671, IET Guidance Note 2, the Electricity at Work Regulations 1989 and the Provision and Use of Work Equipment Regulations 1998. In exceptional cases (e.g. request for multiple LV connections to a small data centre) then it may be necessary to refer to the Policy Engineer - Earthing for guidance.

Although not preferred, it is permissible to provide multiple intake positions and hence multiple connections to a single customer at a single site if each service terminates in a separate building and the customer electrical systems are separate.

5.16 **Communication Stations**

There are a variety of types of 'Communication Station' including radio/television sites, mobile phone base stations and amateur radio/radio 'ham' domestic installations. This section is limited in scope to customer Communication Stations connected to the WPD LV network.

Communication Stations with freestanding housings/structures accessible to the public (e.g. some mobile phone base stations) may also fall within the scope of Section 5.18.

5.16.1 Communication Stations With An Independent Earth Electrode

This section shall be read in conjunction with Section 5.16.3.

NOTE: Some Communication Stations require a low resistance/impedance customer earth electrode for functional and/or lightning protection purposes. Where such an earth electrode is installed its earth resistance may be comparable or less than that of the WPD earthing system. On a PME network, in the event of an open circuit neutral, the customer earth electrode may carry most of the neutral current. There is a risk that the customer earthing conductor and bonding conductors may be insufficient for this current, particularly in the case of a small size service cable.

It is necessary to enquire whether or not the Communication Station has an independent earth electrode. Where it can be established that it does not then a PME Earth Terminal can be provided. Where it has an independent earth electrode or its presence cannot be established then a PME Earth Terminal can be provided subject to:

- a) The customer employing an Embedded TT Earthing System for the part of the Communication Station with the independent earth electrode. See (c) below.
- b) The general requirements in Section 4.2.
- c) In the case where TT earthing in (a) above is not acceptable to the customer (e.g. due to possible nuisance tripping), the customer earthing and bonding conductors being not less than the copper equivalent cross-sectional area of the service neutral.

5.16.2 Communication Stations On/In Other Buildings

Communication Stations on or in other buildings shall be treated as for *Multiple Occupancy Buildings*. See Section 5.15.

5.16.3 Shared Communication Station Towers

Where multiple connections are associated with a Shared Communication Station Tower see Section 5.15.

5.17 **Street Lighting/Road Signs with Required Maximum Capacity $\leq 500W$**

Connections falling within the scope of this section are exempt from the requirement for a customer earth electrode as specified in Section 5.18. For clarity, the following items of equipment are not considered to be within this category; traffic light controllers, ticket machines, speed cameras, advertising hoardings, bus shelters, public telephones, cable television distribution cabinets, communication cabinets and small housings/enclosures containing electrical equipment such as pumps, motors and controls and highway charging points for electric vehicles. Please see Sections 5.18 and 5.19, as appropriate, for this type of equipment.

NOTE: Where a pillar is used the cable/line beyond the supply terminals may constitute a Network⁴³. Where a piece of *Street Furniture* is serviced direct and the owner/operator distributes to other *Street Furniture* this also constitutes a Network. The owner/operator of a Network supplying *Street Electrical Fixtures* is classed as a Distributor and subject to Part II of the ESQC Regulations 2002.

NOTE: The Customer's electrical installation designers/installers can be referred to BS 7671 Section 559 and IET Guidance Notes 5 and 7.

NOTE: The customer must not connect the PME Earth Terminal to crash barriers via their *Main Earth Terminal*.

5.17.1 Connection with No Distributor Network Beyond

In the case of a single connection where there is no Distributor Network fed from it by the owner/operator⁴⁴ a PME Earth Terminal can be provided subject to the following:

- a) In accordance with ST: TP21D, a PME earth is provided no nearer to the substation than the most remote service having a PME Earth Terminal.
- b) The general requirements in Section 4.2.

NOTE: Customer's main equipotential bonding of 6mm² is permitted in specific circumstances – see note in Section 6.4.3.

⁴³ As per the ESQC Regulations 2002, "network" means an electrical system supplied by one or more sources of voltage and comprising all the conductors and other equipment used to conduct electricity for the purposes of conveying energy from the source or sources of voltage to one or more consumer's installations, street electrical fixtures, or other networks.

⁴⁴ See ST: SD5P/2 Arrangements 1 and 2.

- c) The installation is not of *Class II* construction (i.e. 'double insulated' incorporating supplementary/reinforced insulation).

NOTE: The Customer's electrical installation designers/installers can be referred to BS 7671 Regulation 559.10.4.

- d) There being no reasonable expectation that the owner/operator could supply a Network from it; otherwise see Sections 5.17.2 and 5.17.3.

5.17.2 Connection to Distributor with CNE Network

A PME terminal can be provided to a Distributor⁴⁵ with a CNE Network⁴⁶ subject to:

- a) The installation of end of main earth(s) no nearer to the source than the point of connection to their most distant service to their Network distributing main (NB location at the last column fulfils this requirement)⁴⁷ – see Figure 7.

NOTE: It is not permissible for the customer to consider the metallic part of the street light or road sign embedded in the ground to be an earth electrode for the purposes of the end of main earth(s).

- b) The general requirements in Section 4.2.

NOTE: Customer's main equipotential bonding of 6mm² is permitted in specific circumstances – see note in Section 6.4.3.

- c) The installation is not of *Class II* construction (i.e. 'double insulated' incorporating supplementary/reinforced insulation).

NOTE: The Customer's electrical installation designers/installers can be referred to BS 7671 Regulation 559.10.4.

⁴⁵ For example, a Street Lightning Authority.

⁴⁶ See ST: SD5P/2 Arrangements 3, 4 and 5.

⁴⁷ The 40m/4 customer relaxation for end of main earths – see ST: TP21D/1 – does not apply to *Street Electrical Fixtures*.

Figure 7 CNE Distributor Fed from A PME Service

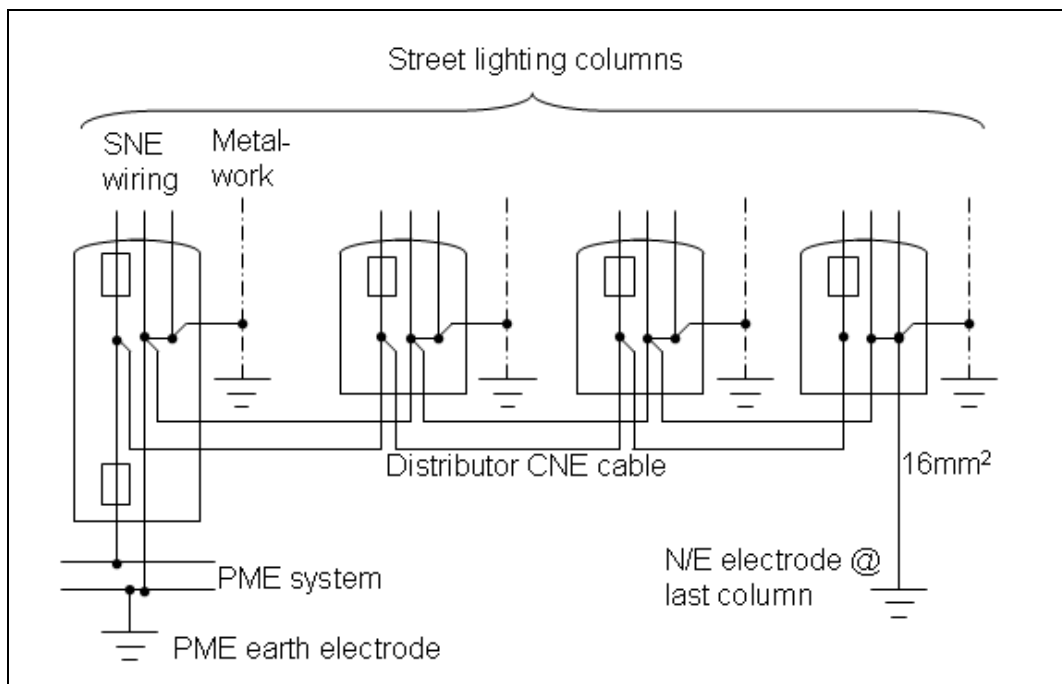

NOTE: The WPD service connection may be to a pillar.

5.17.3 Connection to Distributor with SNE Network

A PME terminal can be provided to a Distributor⁴⁸ – see Figure 8 and ST: SD5P Arrangements 3, 4 and 5 - subject to the following:

The installation of end of main earth(s) at the last service as shown in Figure 8.

- a) the general requirements in Section 4.2

NOTE: Main equipotential bonding of 6mm² is permitted in specific circumstances – see note in Section 6.4.3.

- b) The installation is not of *Class II* construction (i.e. ‘double insulated’ incorporating supplementary/reinforced insulation).

NOTE: The Customer’s electrical installation designers/installers can be referred to BS 7671 Regulation 559.10.4.

⁴⁸ For example, a Street Lightning Authority.

Figure 8 –SNE Distributor Fed from PME Service

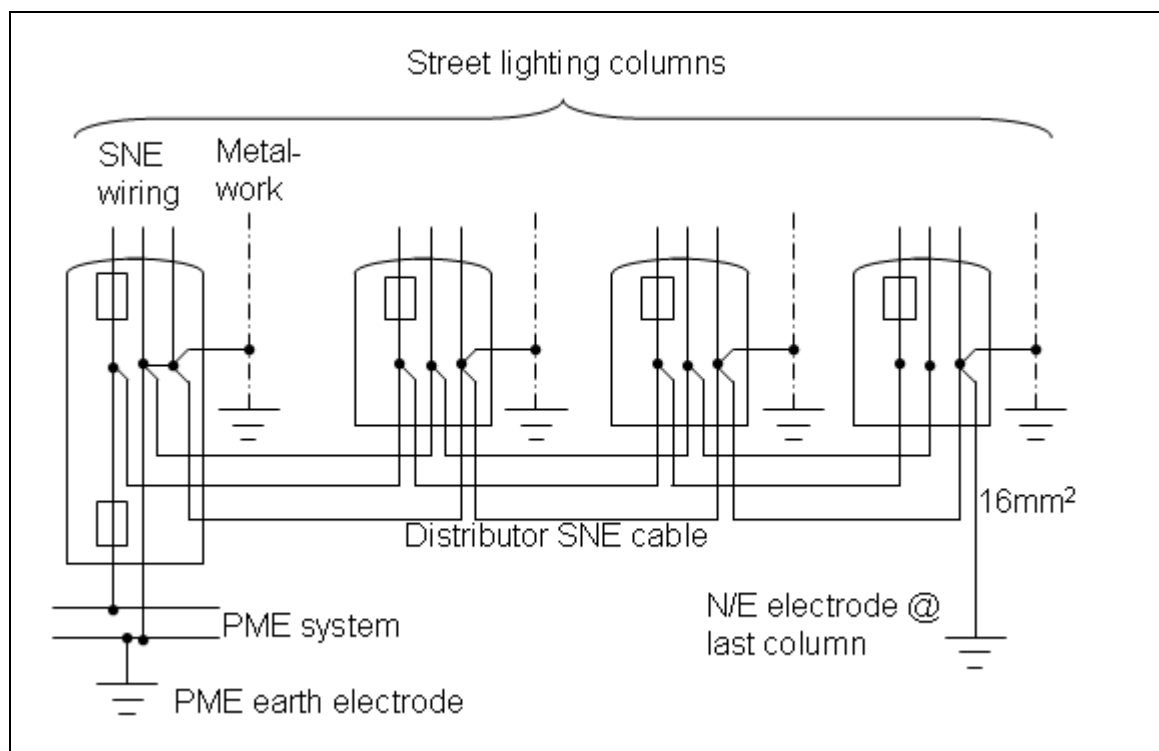

NOTE: The WPD service connection may be to a pillar.

5.18 Street Electrical Fixtures Not Covered By Section 5.17 and Other Housings/Enclosures Accessible to the Public

This section covers *Street Electrical Fixtures* that are not covered by Section 5.17 and also housings/enclosures that do not fall within the definition of *Street Electrical Fixtures* (i.e. not on or associated with the highway); examples may include highway charging points for electric vehicles, traffic light controllers, ticket machines, speed cameras, advertising hoardings, bus shelters, public telephones, cable television distribution cabinets, communication cabinets and small housings/enclosures containing electrical equipment such as pumps, motors and controls.

NOTE: Some of the examples listed above can accept a service direct, whereas in others a pillar is used; ST: SD5P prohibits supply direct to a bollard.

5.18.1 Class II Construction

Street Electrical Fixtures that are not covered by Section 5.17 and other housings/enclosures accessible to the public should preferably be of Class II construction or equivalent as defined in BS 7671.

Class II equipment makes no use of the DNO Earth Terminal and so no WPD Earth Terminal shall ordinarily be provided for supplies direct to *Class II* installations.

However, where expressly requested by the customer, an earth terminal (including a PME earth terminal) may be provided to any street furniture that is either Class II (double-insulated) construction (as defined in BS 7671) or housed in a Class II enclosure.

5.18.2 Class I Construction

5.18.2.1 PME Earth Terminal

A PME Earth Terminal can be provided to Street Electrical Fixtures not covered by Section 5.17 or Other Housings/Enclosures of Class I construction (i.e. exposed-conductive-parts connected to earth terminal – see BS 7671 Part 2) subject to:

- a) Balanced load for split-phase or 3-phase supply, or a customer earth electrode bonded to their Main Earth Terminal having a maximum earth resistance as specified in Table 1 for 1-phase or unbalanced split-phase or unbalanced 3-phase supply.
- b) The general requirements in Section 4.2.

Table 1 – Required Customer Earth Electrode Earth Resistance Versus Load

Connection	Maximum 1-phase load, or, for unbalanced load maximum overall load unbalance	Maximum customer earth electrode resistance bonded to the customer Main Earth Terminal
1-phase, Unbalanced split-phase, or Unbalanced 3-phase	≤500W	100Ω
	≤1kW	60Ω
	≤2kW	20Ω
	≤3kW	14Ω
	≤4kW	11Ω
	≤5kW	9Ω

NOTE: Examples of *Class I* construction include small brick or metal housings/enclosures containing electrical equipment (e.g. communication equipment, pumps, motors or controls).

NOTE: The customer must not connect the PME Earth Terminal to crash barriers, pedestrian guard rails etc via their *Main Earth Terminal*.

5.18.2.2 SNE Earth Terminal

In view of the possible future conversion of SNE networks to PME, a SNE Earth Terminal shall not normally be offered for a supply to Street Electrical Fixtures not covered by Section 5.17 or Other Housings/Enclosures of Class I construction.

An SNE earth terminal may only be provided when it can be guaranteed that there is complete separation of the neutral and earth conductors along the entire length of the circuit (except for at the substation).

Where an SNE earth terminal is provided on a guaranteed SNE main, the WPD mapping system shall be updated with the following note “Guaranteed SNE Main”.

5.18.2.3 TT Earth Terminal

If the conditions for providing a PME earth terminal to a Street Electrical Fixtures not covered by Section 5.17, or Other Housings/Enclosures of Class I construction, cannot be met then no earth terminal shall be provided. The earthing of the installation shall form part of a TT system by installing a separate earth electrode and fitting appropriate RCD protection in accordance with BS 7671.

Care is required in locating TT-earthed equipment in the vicinity of an installation utilizing a PME or SNE Earth Terminal, or in the vicinity of any WPD buried earthing system or traditional paper insulated lead covered cable.

Generally, this will require the Street Electrical Fixture/Other Housing/Other Enclosure to be installed with an above ground separation of at least 2m from other earthed metalwork in order to control the possibility of simultaneous contact with two earth zones.

In addition, the resistance area of a TT earth must not overlap that of network earths and consequently the minimum below ground separation distance specified in Table 2 is required⁴⁹.

Table 2 - Segregation requirement between Earthing Zones

	Single Phase or Unbalanced 3 Phase Connection	Balanced Three Phase Connection
Minimum Below Ground Segregation	3.6m	0.3m

5.18.3 Special Installations: Highways England Feeder Pillars

Feeder pillars associated with supplies to Highways England should preferably be of Class II construction, as mentioned previously in Section 5.18.1.

Where feeder pillars are of Class I construction then the rules for Class I Street Electrical Fixtures as described in Section 5.18.2 should preferably be applied. However, it is recognised there are some applications where this approach is not practicable. In these circumstances the requirements detailed below and illustrated in Figure 9 shall be applied:

- The pillar shall not expose Meter Operator, WPD staff/contractors, Highways England staff/contractors, or members of the public to dangerous touch potentials.
- The pillar shall be surrounded by a 70mm² bare copper conductor grading electrode buried at a minimum depth of approx. 450mm and located approximately 600mm away from all sides of the pillar.
- The pillar and the grading electrode shall be connected to the earth terminal.

⁴⁹ This is based on the following modelled in CDEGS software. A 1.2m vertical earth rod energised at 250V in two-layer soil with soil resistivity of 100Ωm for the top 2m overlying 1000Ωm material gives a voltage of 48V on a 1.2m vertical earth rod separated by 3m horizontally.

5.19 Charging Points for Electric Vehicles

5.19.1 Highway Charging Pillars and associated Street Distribution Pillars

Highway charging pillars and associated street distribution pillars are types of street electrical fixture, and the requirements are covered in Section 5.18 above.

5.19.2 Electric Vehicle Charging Points In Publically Accessible Spaces

Electric vehicle charging points in publically accessible spaces, i.e. spaces that are generally open and accessible to members of the public irrespective of whether publically or privately owned (for example, outdoor car parks) are housings/enclosures accessible to the public and the requirements of Section 5.18 shall apply.

5.19.3 Electric Vehicle Charging Points At Fuel Filling Stations

A PME earth terminal shall not be provided for a supply direct to an electric vehicle charging point located at a fuel filling station and which is within a 10m radius of any extraneous metalwork bonded to the TT earthing system of the fuel filling station:

- The electric vehicle charging point supply shall have a TT earthing system, which shall be bonded to the TT earthing system of the fuel filling station.
- Where an electric vehicle charging point is to be installed at an existing fuel filling station, the installer shall confirm that the fuel filling station does not utilise a WPD Earth Terminal (PME or SNE) in the fuel filling area. Where a legacy earth connection is being utilised, the WPD earth terminal shall be removed prior to energisation of the electric vehicle charge point.
- See Standard Technique SD5G for further details.

A PME Earth Terminal can be provided for a supply direct to an electric vehicle charging point located at a fuel filling station, provided it is positioned 10m or more away from any extraneous metalwork bonded to the TT earthing system of the fuel filling station, and provided it complies with the general requirements in Section 4.2.

NOTE: The IET Code of Practice for Electric Vehicle Charging Equipment Installation provides guidance to Customers' electrical installation designers/installers on earthing arrangements to assist the installer in ensuring that the final installation complies with the relevant requirements of BS 7671 (The Wiring Regulations) and, where necessary, the ESQC Regulations 2002. The Customer's Electrical Installer/Designer is responsible for ensuring that a PME Earth Terminal provided for the premise is used appropriately.

5.19.4 Other Premises Containing Electric Vehicle Charging Points

A PME Earth Terminal can be provided to premises containing an Electric Vehicle Charging Point, subject to the general requirements in Section 4.2.

NOTE: The IET Code of Practice for Electric Vehicle Charging Equipment Installation provides guidance to Customers' electrical installation designers/installers on earthing arrangements to assist the installer in ensuring that the final installation complies with the relevant requirements of BS 7671 (The Wiring Regulations) and, where necessary, the ESQC Regulations 2002. The Customer's Electrical Installer/Designer is responsible for ensuring that a PME Earth Terminal provided for the premise is used appropriately.

The requirements of Section 5.15 are also applicable in the case of requests for multiple intakes/connections to the premises.

5.20 Parallel LV Generators

5.20.1 Solar Photovoltaic (PV) Systems

Solar PV Systems are frequently roof-mounted, sometimes directly integrated into the fabric of a building, but they can also be fixed to framework on open ground. In some cases, they are arranged as a dedicated 'solar farm'.

In accordance with Section 4.3, PME shall not be offered direct to a Solar PV System (i.e. dedicated Solar PV Farm). A PME Earth Terminal can be provided to other types of installation that include embedded Solar PV Systems that form part of a larger installation (e.g. roof-mounted) subject to the general requirements in Section 4.2. It is the customer's electrical installation designer's/installer's decision as to whether to use the terminal for the Solar PV System.

NOTE: The Government publication 'Photovoltaics in Buildings – Guide to the Installation of PV Systems', 2nd Edition, 2006, ETSU Report Number ETSU S/P2/00355/REP/1, provides guidance to Customers' electrical installation designers/installers on earthing arrangements and on when an electrical installation designer/installer can utilise the PME Earth Terminal for earthing the PV array frame.

In the case that the PV system comprises *Class II* modules and *Class II* cables, connectors/connections and junction boxes and isolating transformers in the inverters then the guide advises that the PV array frame should be left floating. Where the above does not apply then if the array is within the '*Equipotential Zone*⁵¹' then the guide advises that the PV array frame should be bonded to the customer *Main Earth Terminal*; if the array is not within the '*Equipotential Zone*' then the guide advises that the PV array frame should be bonded to the customer *Main Earth Terminal* if the earthing is not PME or, if PME is present, that TT earthing is required for the PV array frame. Note that this latter point does not explicitly address the issue of shock risk across two earth zones that could exist if the PV array frame on a TT earth is within 2.5m of metalwork bonded to the PME terminal – this could be addressed by locating the array further away or by the same method employed with *Charging Points for Electric Vehicles* – see Section 5.19.

5.20.2 Other Parallel LV Generators

Other Parallel LV Generators (e.g. wind turbines) shall be treated in the same way as Solar PV Systems – see Section 5.20.1 – with respect to provision of PME Earth Terminals.

5.21 Metalclad & Similar Buildings Presenting External Earthed Metallic Parts

In the case of single-occupancy and three-phase supply, a PME Earth Terminal can be provided to *Metalclad & Similar Buildings Presenting External Earthed Metallic Parts* (i.e. outside the *Equipotential Zone*).

In the case of *Multiple Occupancy Buildings* see Section 5.15.

For temporary buildings see Section 5.4.

NOTE: The customer's electrical designer/installer is responsible for deciding whether to connect the PME Earth Terminal to the customer *Main Earth Terminal*. It is generally safe under normal loading conditions to make use of the PME Earth Terminal. However, this may not be the case with extreme load unbalance (i.e. >40%).

In the case of single-occupancy and single-phase/split-phase supply, a PME Earth Terminal can be provided to *Metalclad & Similar Buildings Presenting External Earthed Metallic Parts* subject to the customer having their own earth electrode of 20Ω or less connected to their *Main Earth Terminal*.

NOTE: BS 7671 recognizes underground structural metalwork embedded in foundations as a type of earth electrode.

⁵¹ '*Equipotential Zone*' is defined as a zone in which *Exposed-conductive-parts* and *Extraneous-conductive-parts* are maintained at substantially the same potential by bonding, such that, under fault conditions, the differences in potential between simultaneously accessible *Exposed-conductive-parts* and *Extraneous-conductive-parts* will not cause electric shock. '*Extraneous-conductive-parts*' are conductive parts liable to introduce a potential, generally earth potential, and not forming part of the electrical installation, such as a water pipe, outside tap, a metal downpipe (i.e. anything conductive that is connected to 'Earth' but not electrically part of the system). Note that free-standing ground-mounted or building roof-mounted arrays, away from building metalwork, will normally not be within the *Equipotential Zone*. However, a solar thermal system or other building linked metalwork, installed within reach may extend the *Equipotential Zone* outside the normal building envelope.

6.0 BACKGROUND INFORMATION

6.1 Types Of Earthing

BS 7671 Regulation 312.3 defines four types of earthing:

- a) TN-S
- b) TN-C-S
- c) TT
- d) IT

The FIRST letter defines the SUPPLY earthing arrangement:

T = direct connection of the supply with earth.

I = Supply unearthed or earthed via a limiting impedance.

The SECOND letter defines the INSTALLATION earthing arrangement:

N = *Exposed-conductive-parts* of the installation directly connected to the earthed point of the supply.

T = *Exposed-conductive-parts* of the installation directly connected to earth, independent of the earthing of any point of the supply

The THIRD and FOURTH letter defines the arrangement of the neutral and protective conductor:

S = separate neutral and earth (protective) conductors

C = neutral and earth combined in a single conductor.

6.1.1 TN-S Earthing

Figure 10 – TN-S Type of Earthing

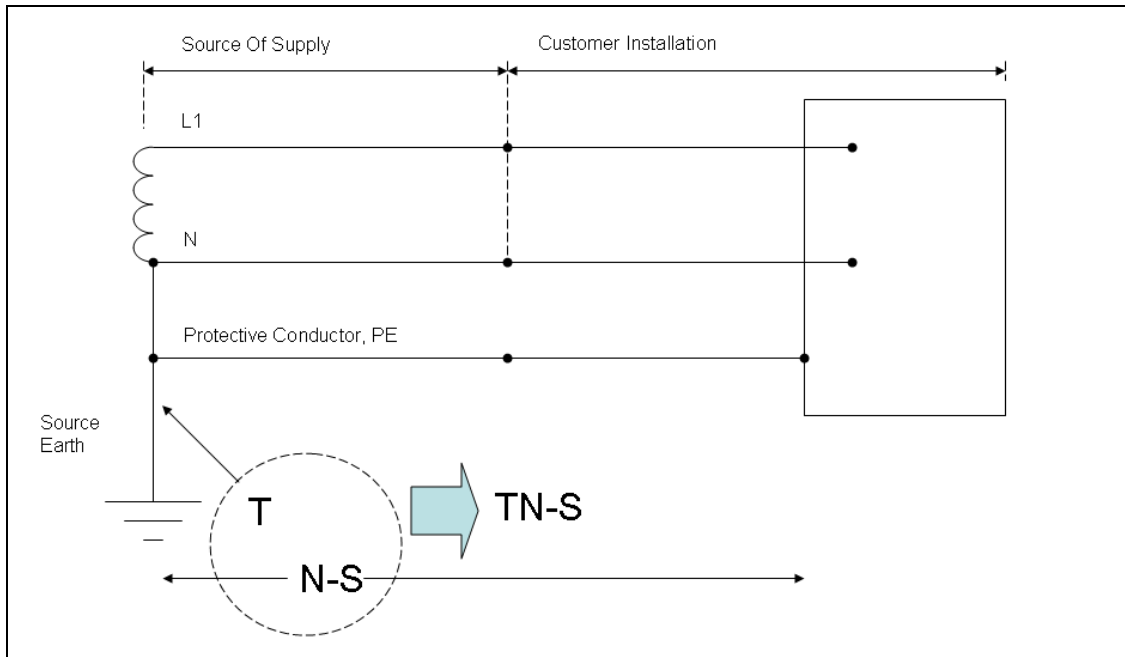

6.1.2 TN-C-S Earthing

Figure 11 – TN-C-S Type of Earthing

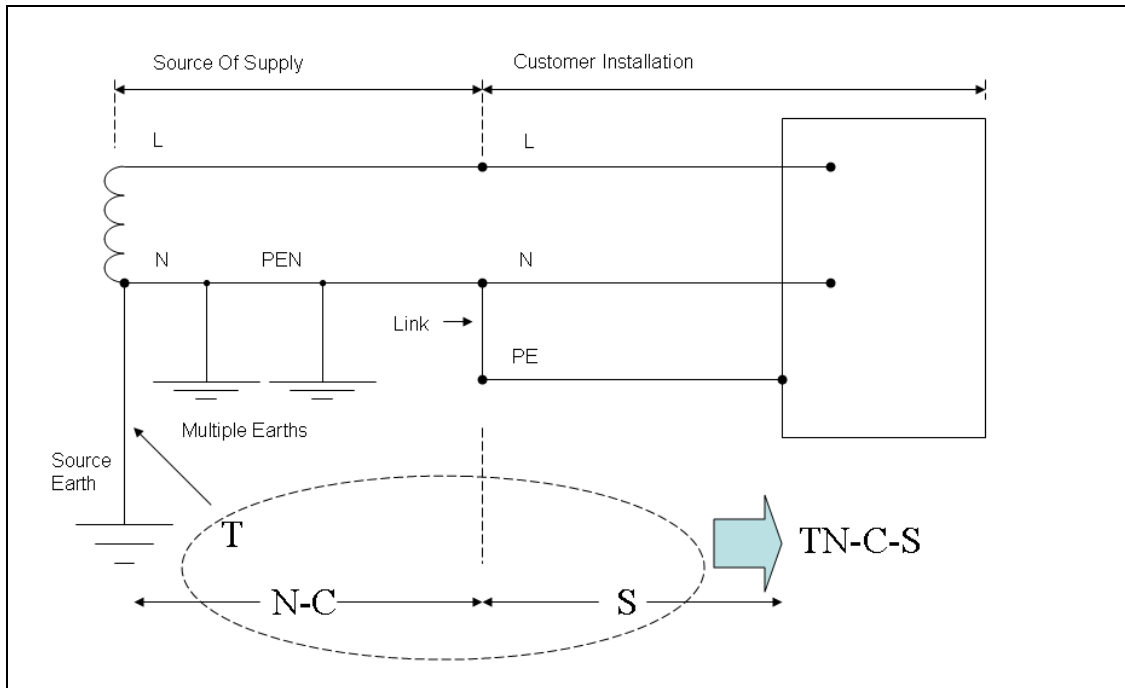

6.1.3 TT Earthing

Figure 12 – TT Type of Earthing

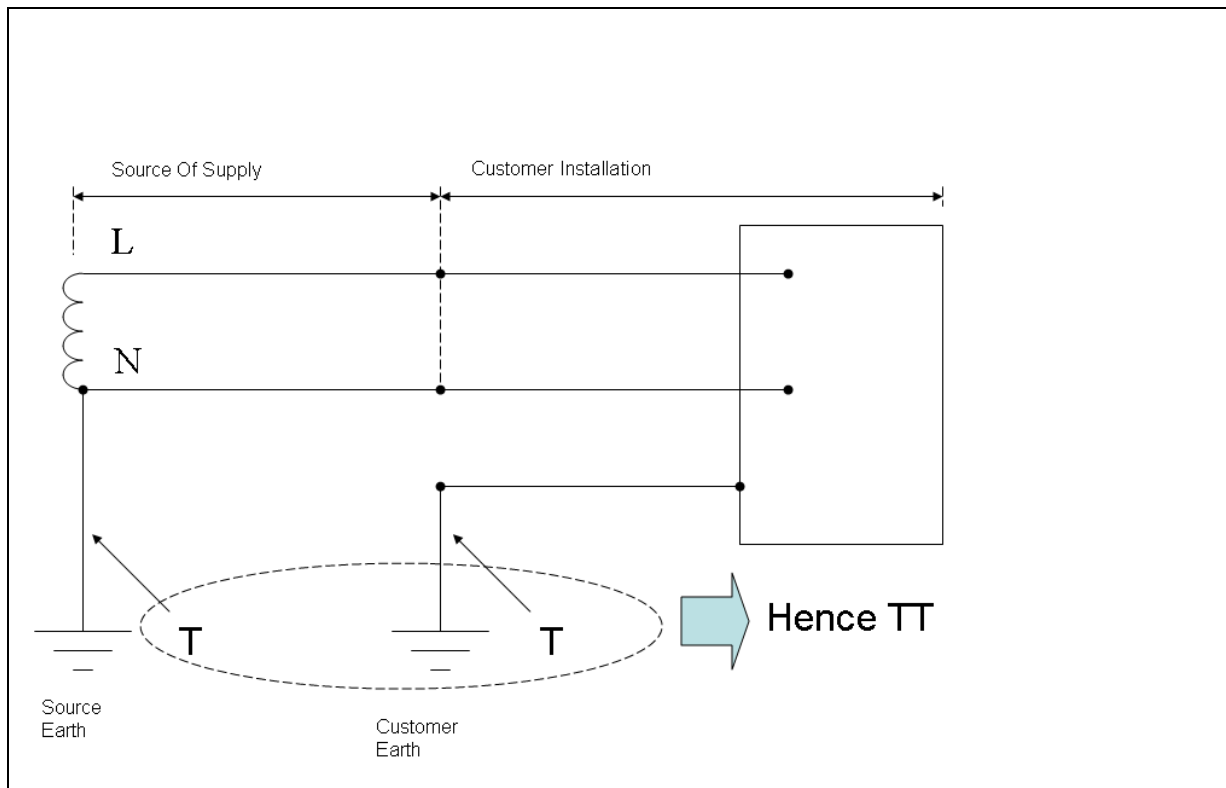

6.1.4 Protective Neutral Bonding

In accordance with the ESQC Regulations 2002, the supply neutral conductor should be connected with earth at the neutral point of the local transformer (i.e. as close as possible to the source, to ensure that all consumers connected to multiple low voltage cables benefit from a secure common earth at the electrical centre of the network). However, there is an exception in regulation 8(3)(b) for protective neutral bonding (PNB) arrangements in which it is permissible for the connection to earth to be situated away from the local transformer and close to the load. Where multiple consumers are supplied from a dedicated pole mounted transformer, the connection with earth shall be closer to the local transformer than any of the service connections.

Depending upon whether the earth connection to the customer is taken from the transformer neutral earth or from the neutral direct this can be viewed as either TN-S or TN-C-S. See Figure 13 and Figure 14.

Figure 13 – PNB variant with aerial overhead service – TN-S

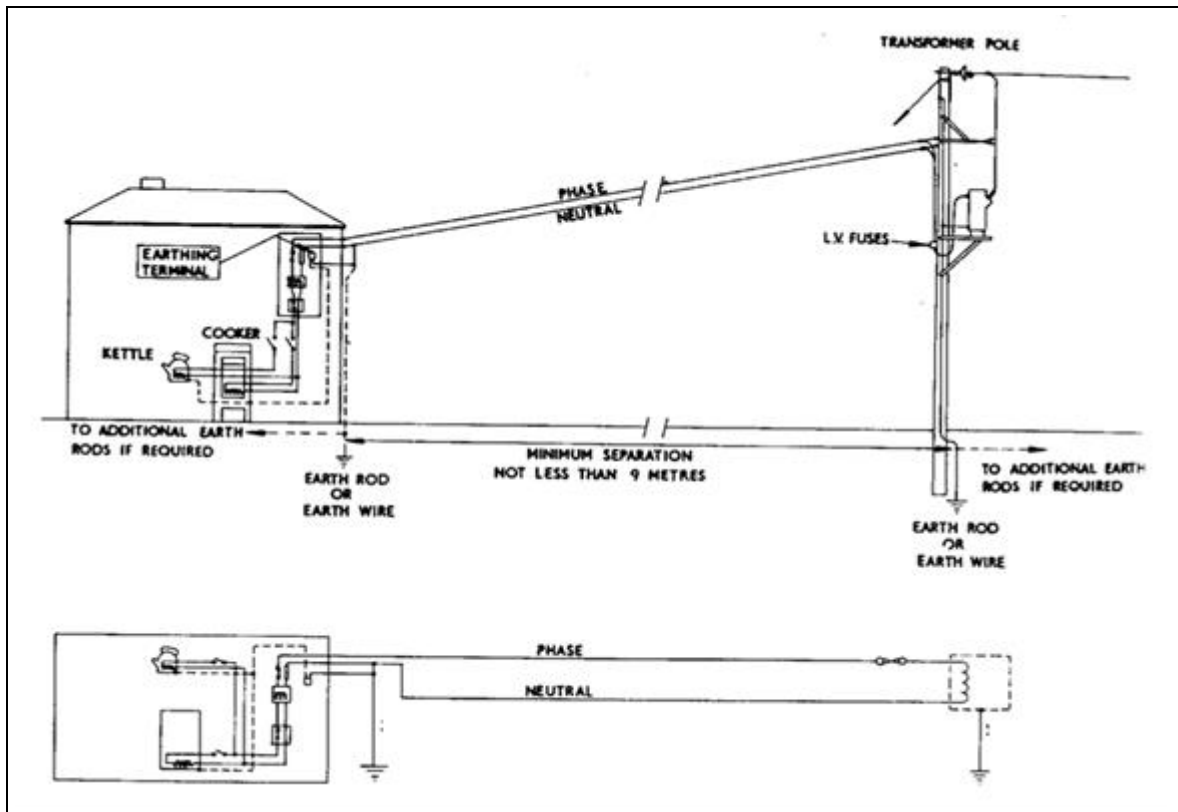
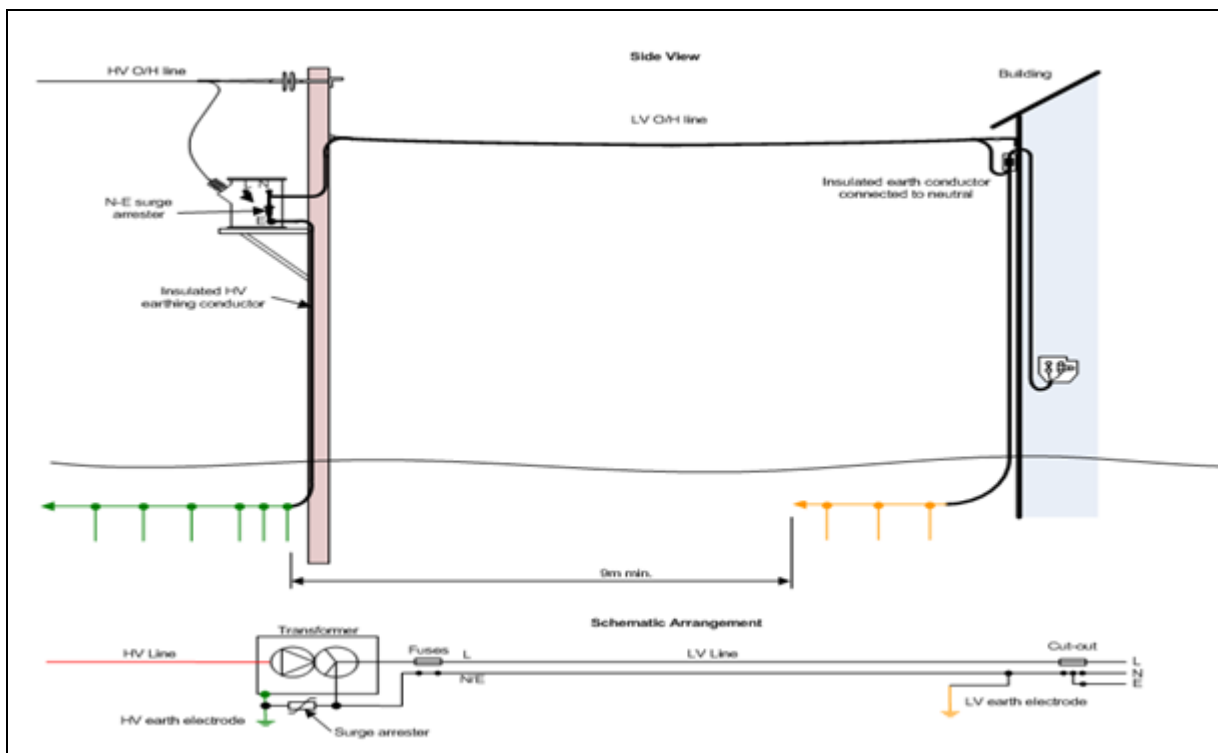

Figure 14 – PNB variant – TN-C-S



6.2 Definitions

6.2.1 Definition of Types Of Earthing System

Type of Earthing	Definition
TN System	A system having one or more points of the source of energy directly earthed, the <i>Exposed-conductive-parts</i> of the installation being connected to that point by productive conductors.
TN-C System	<p>A system in which neutral and protective functions are combined in a single conductor throughout the system.</p> <p>NOTE: The ESQC Regulations 2002 states that 'a consumer shall not combine the neutral and protective functions in a single conductor in his consumer's installation'. TN-C is therefore not a common form of Customer earthing as it requires an exemption from the Regulations.</p>
TN-C-S System	<p>A system in which neutral and protective functions are combined in a single conductor in part of the system</p> <p>NOTE: A system with PME applied to it is an example of a TN-C-S system: in the distribution system the neutral and protective conductors are combined; in the consumer's installation the neutral and protective conductors are separate.</p>
TN-S System	<p>A system having separate neutral and protective conductors throughout the system.</p> <p>NOTE: Cable sheath earth return and separate continuous aerial earth wire are examples of a TN-S system. The neutral of the source is connected with Earth at one point only, at or as near as is reasonably practicable to the source, and the SNE Earth Terminal is connected to the metallic sheath or armour of the service cable or aerial earth wire.</p>
TT System	A system having one point of the source of energy directly earthed, the <i>Exposed-conductive-parts</i> of the installation being connected to earth electrodes electrically independent of the earth electrodes of the source.
IT System	<p>A system having no direct connection between live parts and Earth, the <i>Exposed-conductive-parts</i> of the installation being earthed.</p> <p>NOTE: An IT system is not permitted for a Distributor because the source is not directly earthed which contravenes the ESQC Regulations 2002.</p>

Type of Earthing	Definition
Protective Multiple Earthing (PME)	<p>An earthing arrangement, found in TN-C-S systems, in which the supply neutral conductor is used to connect the earthing conductor of an installation with earth, in accordance with the ESQC Regulations 2002; that is, a Distributors' low voltage network in which the neutral and protective functions are combined</p> <p>NOTE: Protective Multiple Earthing is a method of providing an earth for the electrical installation of a LV Customer by connecting the Customer's Main Earthing Terminal to the neutral of the Distributors' LV network, hence providing the Customer with a continuous earthing connection via the system neutral back to the supply transformer. The earth terminal installed at the Customers' supply position is called a PME Earth Terminal. In a PME system, the Distributor's neutral conductor performs the dual role of both an earthing and neutral conductor.</p> <p>NOTE: A system with a single network earth can fall within the ESQC definition of PME. A system with PNB is PME if the neutral-earth connection is made at the cut-out.</p>
Protective Neutral Bonding (PNB)	<p>PNB refers to the situation where there is only one point in a network at which consumer's installations are connected to a single source of voltage; in such a case the supply neutral conductor connection to earth may be made at that point, or at another nearer to the source of voltage.</p> <p>NOTE: If the WPD Earth Terminal for the Customer is derived by connecting direct to the neutral-earth earthing conductor (e.g. as it drops down outside of customer building) then this is a form of TN-S earthing. However, if the WPD Earth Terminal for the Customer is derived by connecting the earth into the cut-out then this is a form of TN-C-S and falls within the definition of PME even though the neutral is not multiple earthed.</p>

6.2.2 Definition of Installation Types

Installation Type	Definition	Source
Agricultural and Horticultural Premises	Rooms, locations or areas where: <ul style="list-style-type: none"> • livestock are kept, or • feed, fertilizers, vegetable and animal products are produced, stored, prepared or processed, or • plants are grown, such as greenhouses. 	BS 7671
Amusement Device	Ride, Stand or membrane building, side stall, side Show, tent, Booth or grandstand intended for the entertainment of the public.	BS 7671
Booth	Non-stationary unit, intended to accommodate equipment generally for pleasure or demonstration purposes.	BS 7671
Caravan	A trailer Leisure Accommodation Vehicle, used for touring, designed to meet the requirements for the construction and use of road vehicles. NOTE: "So far as the law is concerned, a park/mobile home, a caravan holiday home, touring caravan or Gypsy and Traveller home are all capable of coming within the legal definition of a caravan provided they retain the element of mobility. Mobility, in this context, means that the caravan must be capable of being moved when assembled from one place to another. This means that it cannot be fixed to the ground. Permanent works, such as a large porch or extension, which fix the caravan to the ground could mean that a caravan no longer comes within the legal definition of a caravan and could as a consequence be treated as a building." (K Morton, HSE, 27/05/2009)	BS 7671
Caravan Park/Camping Park	Area of land that contains two or more caravan pitches and/or tents	BS 7671
Extraneous-conductive-part	A conductive part liable to introduce a potential, generally earth potential, and not forming part of the electrical installation.	BS 7671
Fairground	Area where one or more Stands, Amusement Devices or Booths are erected for leisure use.	BS 7671
Fuel Filling Station	The forecourt and associated shop at a fuel filling station (e.g. Petrol or LPG). Areas where dangerous/explosive substances are stored (e.g. bulk storage installations) are treated in the same way as a Fuel Filling Station.	

Installation Type	Definition	Source
Houseboat	Floating decked structure which is designed or adapted for use as a place of permanent residence often kept in one place on inland water.	BS 7671
Impressed Current Cathodic Protection System	A corrosion protection system using impressed DC current. NOTE: Pipelines routinely employ this type of corrosion protection.	
Leisure Accommodation Vehicle	Unit of living accommodation for temporary or seasonal occupation which may meet requirements for construction and use of road vehicles	BS 7671
Marina	Facility for mooring and servicing pleasure craft with fixed wharves, jetties, piers or pontoon arrangements capable of berthing one or more pleasure craft.	BS 7671
Mobile Home	A transportable Leisure Accommodation Vehicle which includes means for mobility but does not meet the requirements for construction and use of road vehicles.	BS 7671
Mobile/Transportable Unit	A vehicle and/or transportable structure in which all or part of a low voltage electrical installation is contained, which is provided with a temporary supply by means of, for example, a plug and socket outlet.	BS 7671
Motor Caravan	Self-propelled Leisure Accommodation Vehicle, used for touring, that meets the requirements for the construction and use of road vehicles.	BS 7671
Multiple Occupancy Building	A building comprised of more than a single Premises, excluding residential Premises that do not have a communal area. In this context, Premises is defined as a part of a Multiple Occupancy Building occupied by a single customer.	EREC G87, amended
Outdoor Amenity Showers and Outdoor Amenity Facilities	A shower or dish-washing facility external to the Equipotential Zone of a building/structure for amenity purposes (e.g. beach-side showers or sinks outside a toilet amenity block).	
Pleasure Craft	Any boat, vessel, yacht, motor launch, Houseboat or other floating craft used exclusively for sport or leisure.	BS 7671
Residential Park Home	A factory produced relocatable dwelling designed for permanent residence which may be used for leisure purposes.	BS 7671

Installation Type	Definition	Source
Show	Display or presentation in any suitable location, either a room, building or temporary structure.	BS 7671
Sports Pavilion	A building adjacent to a sports ground used for changing clothes and/or partaking of refreshments; it may include a shower area (e.g. cricket club-house).	
Stand	Area or temporary structure used for display, marketing or sales.	BS 7671
Street Electrical Fixture	A permanent fixture which is or is intended to be connected to a supply of electricity and which is in, on, or is associated with a highway.	ESQC 2002
Street Furniture	Fixed equipment located on a highway. Note: Street Furniture includes Street Located Equipment	BS 7671
Street Located Equipment	Fixed equipment, located on a highway, the purpose of which is not directly associated with the use of the highway.	BS 7671

6.2.3 Definition of Other Terms

Installation Type	Definition	Source
Class I Equipment	Equipment in which protection against electric shock does not rely on basic insulation only, but which includes means for the connection of Exposed-conductive-parts to a protective conductor in the fixed wiring of the installation.	BS 7671
Class II Equipment	Equipment in which protection against electric shock does not rely on basic insulation only, but in which additional safety precautions such as supplementary insulation are provided, there being <u>no provision for the connection of exposed metalwork of the equipment to a protective conductor</u> , and no reliance upon precautions to be taken in the fixed wiring of the installation.	BS 7671
Earth	The conductive mass of the Earth, whose electric potential is conventionally taken as zero.	
Earth Electrode	Conductive part, which may be embedded in the soil or in a specific conductive medium (e.g. concrete) in electrical contact with the Earth.	BS 7671
Earthing Conductor	A protective conductor connecting the main earthing terminal of an installation to an earth electrode or to other means of earthing.	BS 7671
Equipotential Zone	A zone in which Exposed-conductive-parts and Extraneous-conductive-parts are maintained at substantially the same potential by bonding, such that, under fault conditions, the differences in potential between simultaneously accessible Exposed-conductive-parts and Extraneous-conductive-parts will not cause electric shock.	BS 7671
Exposed-conductive-part	Conductive part of equipment which can be touched and which is not normally live, but which can become live under fault conditions.	BS 7671
Extraneous-conductive-part	A conductive part liable to introduce a potential, generally earth potential, and not forming part of the electrical installation.	BS 7671
Main Earthing Terminal	The terminal or bar provided for the connection of protective conductors, including protective bonding conductors, and conductors for functional earthing.	BS 7671

Installation Type	Definition	Source
Protective Bonding Conductor	Protective conductor provided for protective equipotential bonding.	BS 7671
Protective Conductor (PE)	A conductor used for some measures of protection against electric shock and intended for connecting together any of the following parts: <ul style="list-style-type: none"> Exposed-conductive-parts Extraneous-conductive-parts The Main Earthing Terminal Earth Electrode(s) The earthed point of the source, or an artificial neutral. 	BS 7671

6.3 Principles of Customer Installation Earthing

The customer's electrician/electrical designer is responsible for the decision as to whether or not to use a WPD Earth Terminal, if offered, as their Means of Earthing. Customer installation earthing beyond the supply terminals is the customer's responsibility and not that of WPD. However, it is useful to understand the objectives in earthing a customer installation and the terminology used. Furthermore, the limited inspection done under ST: NC5A prior to connection involves a visual check includes looking at the size of the earthing conductor present, if any; the minimum sizes are described below. This section also explains the principles of when the offer of a PME earth terminal is conditional.

If a fault occurs connecting a LIVE conductor to metalwork that is not earthed then the LIVE metalwork will present an electric shock hazard. See Figure 15.

Figure 15 – Indirect Contact Electric Shock Hazard – Metalwork Unearthed

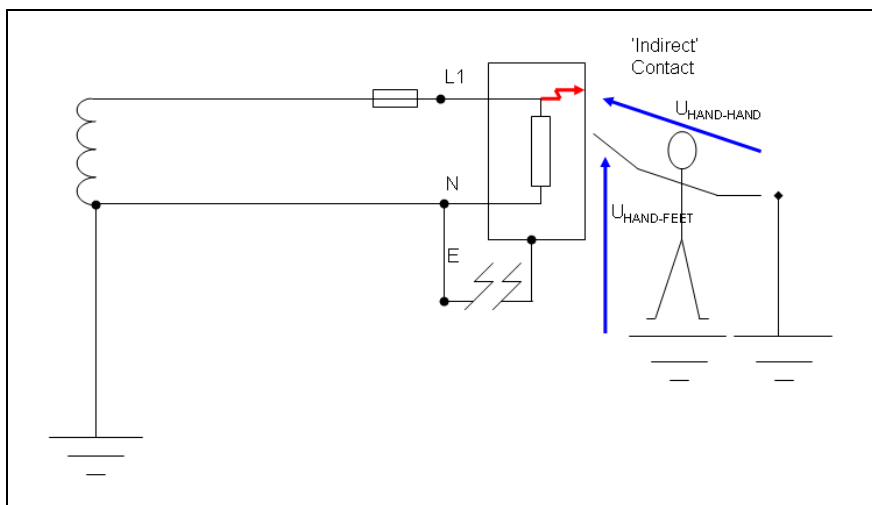

It is sometimes assumed that earthed customer metalwork will not be hazardous, even under fault conditions. This, however, is not necessarily true because a person can experience a 'touch voltage' between exposed metalwork; this is referred to as 'indirect contact' as the contact is not directly to a LIVE conductor. BS 7671 now refers to 'fault protection' where this is protection against indirect contact, mainly with regard to failure of 'basic insulation'. BS 7671 defines rules for 'fault protection'. These include the most commonly applied method; namely 'automatic disconnection of supply', formerly known as 'earthed equipotential bonding and automatic disconnection of supply'.

The key principles of this method are:

- a) Earthing of the installation equipment (i.e. 'Exposed-conductive-parts'). See Figure 16.
- b) Equipotential bonding of non-electrical metalwork (i.e. 'Extraneous-conductive-parts'). See Figure 16
- c) Automatic disconnection by sufficiently low earth fault loop impedance and sufficiently fast protective devices to prevent electric shock.
- d) Use of protective conductors of sufficient size to carry the prospective current allowing the protective devices to operate as intended.

Figure 16 – Earthing Terminology – Customer's Installation

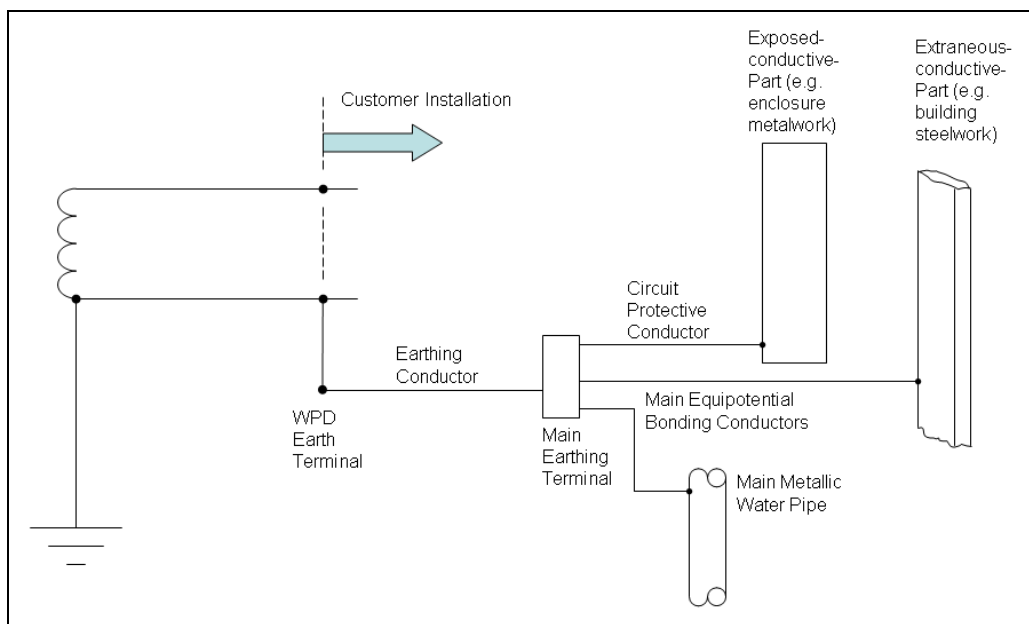

BS 7671 defines how fault protection, also known as protection against indirect contact, shall be achieved, including sizes of earthing and bonding conductor, what should be earthed and bonded etc. Note that 'equipotential bonding' is the connection together of 'Exposed-conductive-parts' and 'Extraneous-conductive-parts' to minimize any voltage difference between them that might occur during an earth fault. Bonding reduces the touch voltage for indirect contact – see Figure 17.

Figure 17 – Effect of Bonding on Indirect Contact Touch Voltage

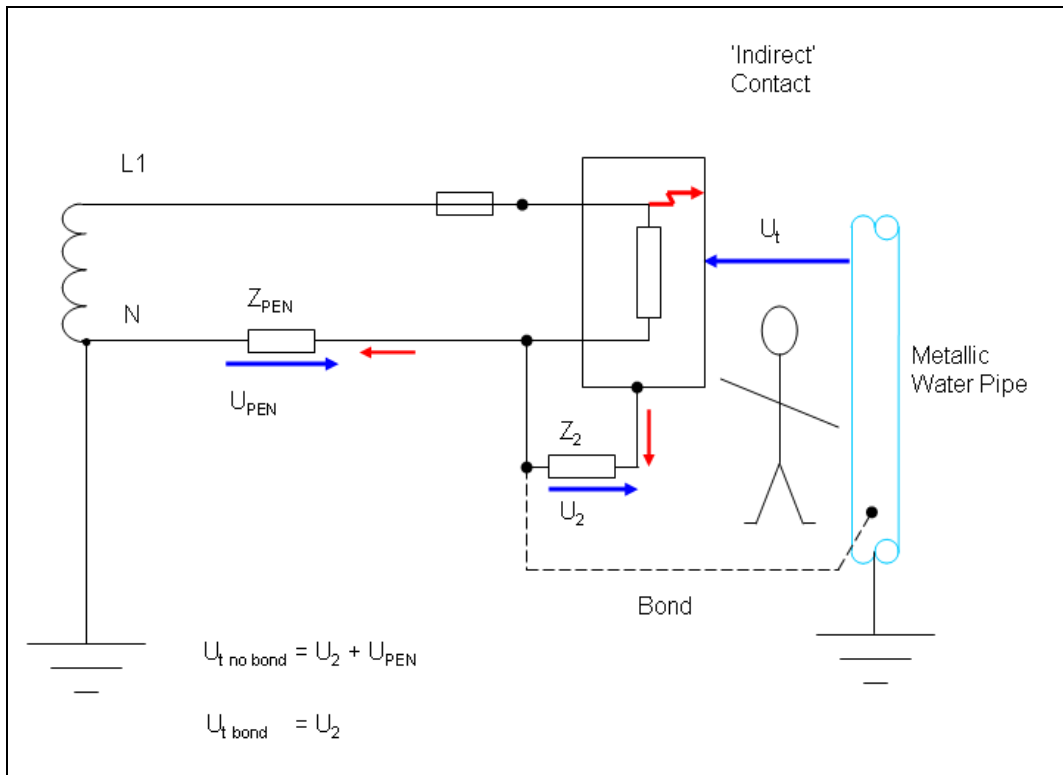

BS 7671 also defines automatic disconnection times; this directly affects the maximum earth loop impedance for a given overcurrent protective device. Residual Current Devices (RCDs) provide an alternative where this requirement cannot be met – see Figure 18. Note that RCD use will be more prevalent as BS 7671 now requires additional protection through 30mA RCDs for all socket outlets⁵² (with two exceptions⁵³) – full details are given in BS 7671 Regulation 411.3.3.

Figure 18 – RCD Protection for TT System

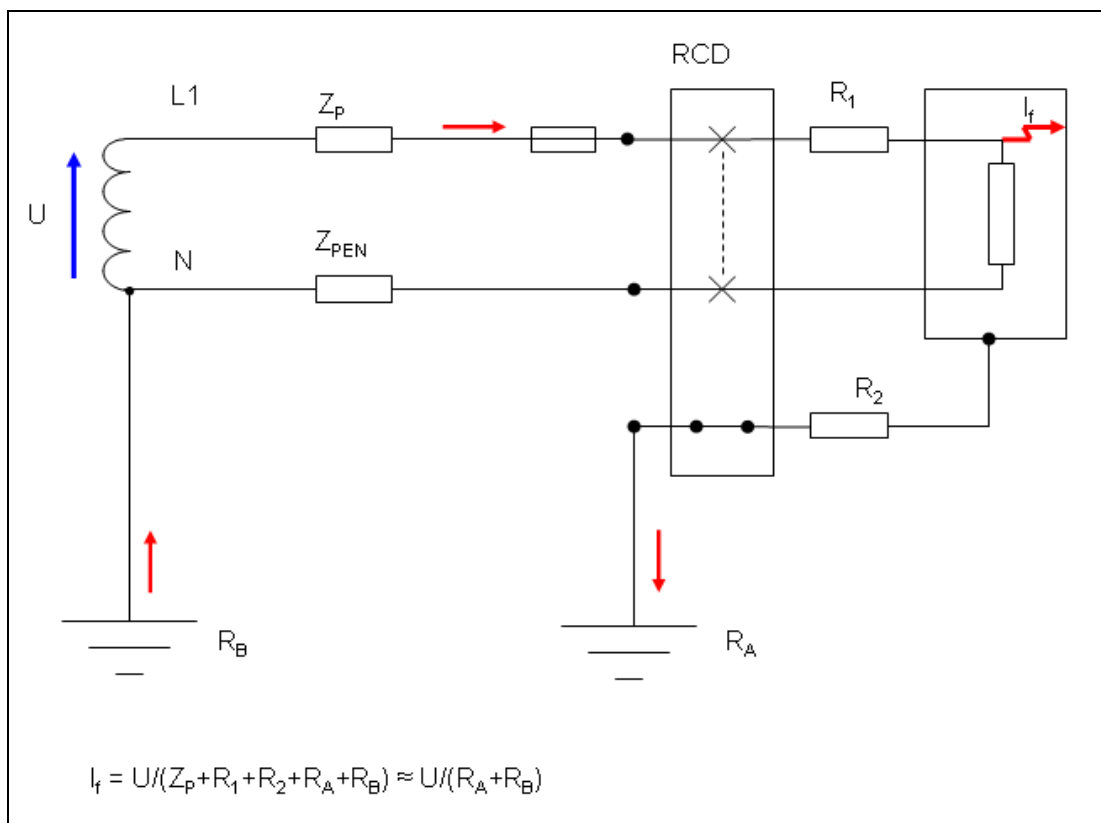

⁵² This refers to socket-outlets with rated current $\leq 20A$ that are for use by ordinary persons and are intended for general use.

⁵³ The exceptions are i) socket-outlets for use under the supervision of skilled or instructed persons (e.g. in some commercial or industrial locations) ii) a specific labelled or otherwise suitably identified socket-outlet provided for connection of a particular item of equipment.

6.4 TN-C-S (PME)

6.4.1 Applications

When a PME Earth Terminal is used by a customer our neutral acts as a combined neutral and earth return, giving the customer a combined continuous metallic neutral and earth connection back to the supply transformer neutral.

With a TN-C-S (PME) system, if the neutral should break a touch voltage may appear on customer installations. In the worst case conductive-parts may be at the same voltage as the LIVE conductor. See Figure 19. The (former) Department of Trade and Industry (DTI) comment that:

'There is a small inherent risk of danger to consumers (resulting from the possible disconnection of the supply neutral conductor under fault conditions) with all PME networks (see comments for regulation 7(1)), however it is DTI's view that the risks are acceptable provided that:

- a) distributors comply with the requirements for multiple earthing (regulation 9(2)) and take precautions to ensure continuity of the supply neutral conductor (regulation 7(1)); and,
- b) consumers comply with the equipotential bonding requirements of *BS 7671 Requirements for Electrical Installations*. Distributors should note that at the time of connection they should be satisfied that consumers' installations comply with *BS 7671* (see regulation 25 *Connections to installations or to other networks*).'

Figure 19 - Touch Voltage For Broken Neutral – TN-C-S (PME) System

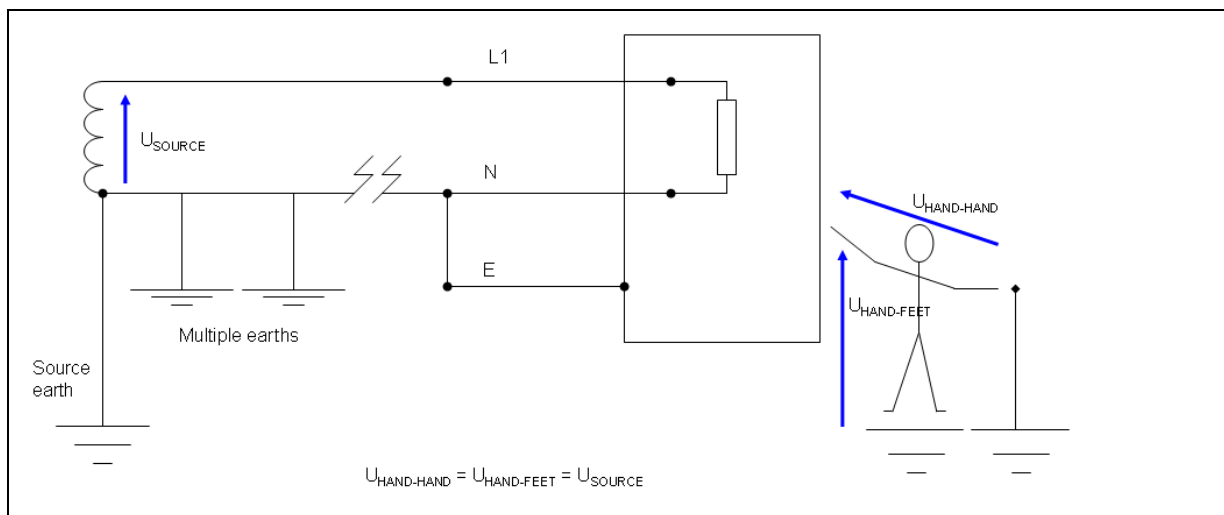

There are situations where, for reasons of safety, a PME Earth Terminal must not be provided – see Sections 4.3 and 0.

Earth electrode beyond the break in a neutral (looking from the source), where present, serves to reduce the touch voltage as shown in Figure 20.

Figure 20 – Touch Voltage Control By Earth Electrode Beyond PME Neutral Break

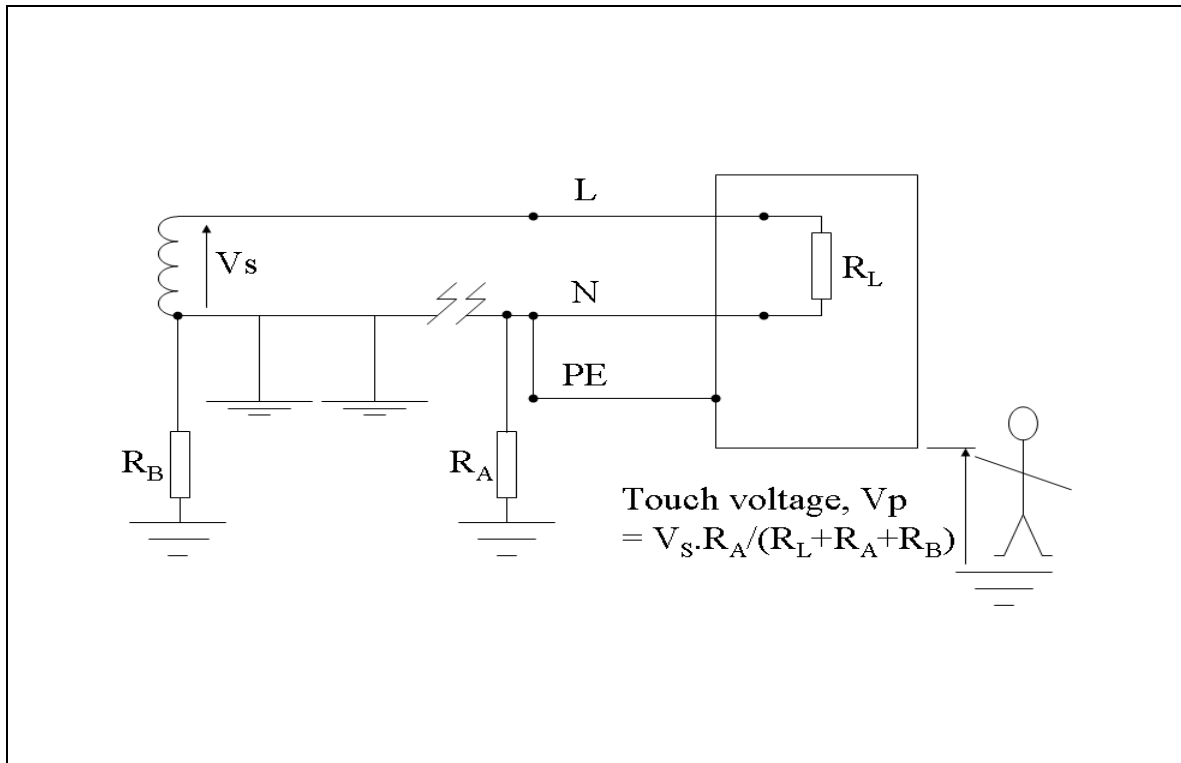

Note that another feature of PME networks is that under normal operation a voltage appears on the neutral caused by the return of load current to the source. Where a customer uses a PME Earth Terminal they will be presented with a voltage on their earthed metalwork that is above true earth. See Figure 21.

Figure 21 – Neutral-Earth Voltage on PME Earth Terminal

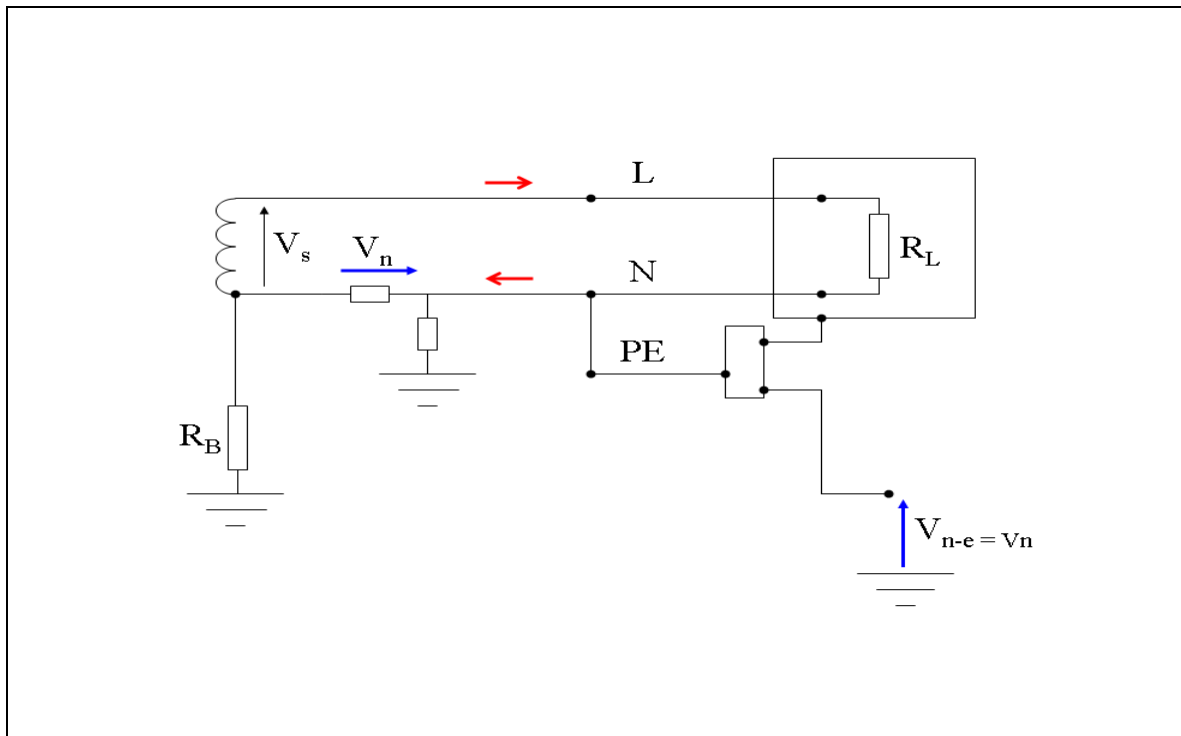

With a PME system the returning load current is able to flow in both the neutral and all parallel earth paths which may include customer earthing. See Figure 22. In the case of a broken neutral the current flowing into customer earthing may be significant if the customer has a low earth resistance electrode system.

Figure 22 – Neutral Current Diversion with PME

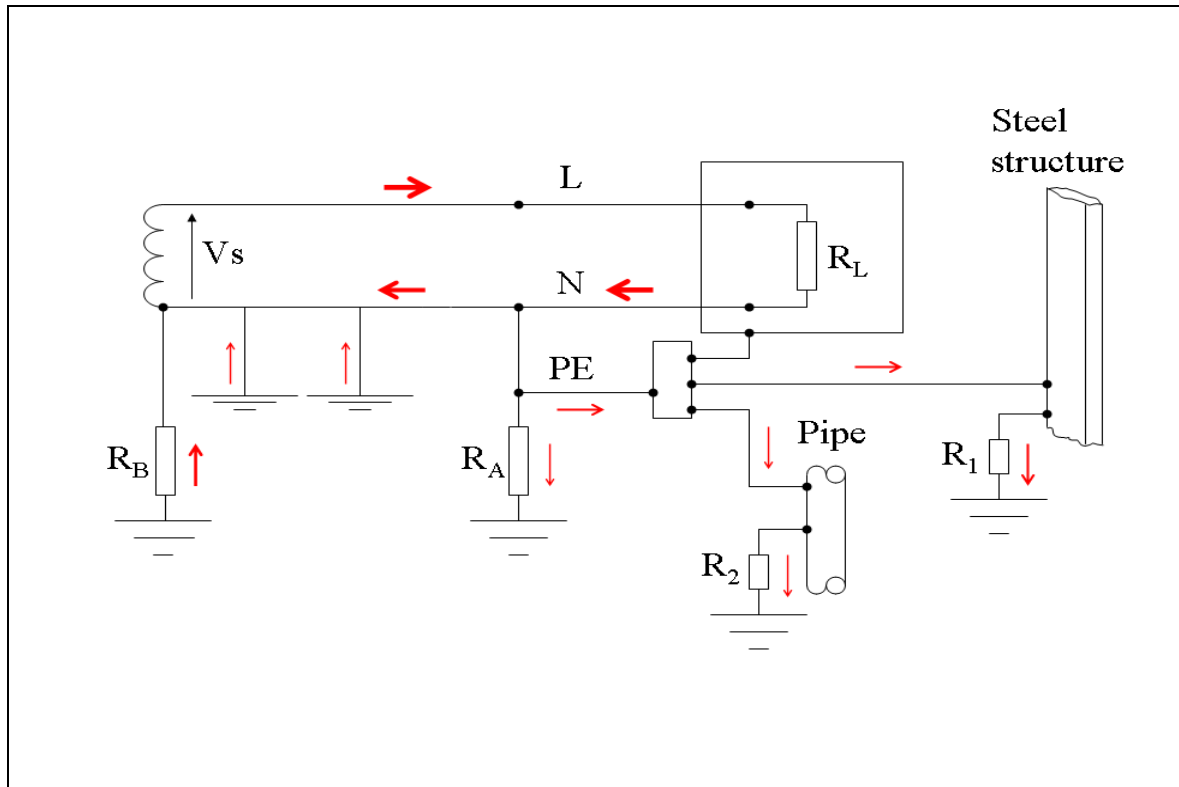

6.4.2 Conditional PME Application

The reasoning underlying whether the offer of a PME Earth Terminal is conditional / prohibited is based on the risks involved. In general, increased risk occurs in the following cases:

- If a broken neutral is more likely (e.g. a service terminates in a temporary structure/building).
- If ignition of hazardous product by diverted neutral current, neutral voltage or associated arc is possible (e.g. Fuel Filling Station).
- If discomfort could occur due to neutral-local earth voltage (e.g. Sports Pavilion shower, Swimming Pool, milking parlour etc).
- If equipotential bonding is difficult to install/keep (e.g. Construction Site, Agricultural Premise, Show, Circus, Mine, Quarry etc)
- If electric shock is more likely for a broken neutral (e.g. likely to be barefoot, single phase causing large neutral current, large current unbalance causing neutral current etc)
- If overheating/fire due to diverted neutral current is more likely (e.g. low customer installation earth resistance and large current unbalance).

6.4.2.1 Additional Guidance For Mobile/Transportable Units

Mobile/Transportable Units are treated like *Caravans* unless specific circumstances apply; they cannot be given a PME Earth Terminal direct except as explained in Section 5.2. They can, however, be given a supply by a customer whose installation has a PME Earth Terminal from a point within that customer's installation; this situation is governed by the Electricity at Work Regulations 1989 and, in particular, Regulation 8 and 9. The following guidance is given:

'These two regulations require precautions to be taken to prevent danger arising as a result of a fault in the distributor's network, in particular networks with a combined neutral and protective (PEN) conductor, that is PME, networks. A particular precaution required by BS 7671 is main bonding to all incoming services. Another precaution that can be taken is the connection of earth electrodes to the main earthing terminal, e.g. underground structural steelwork, water pipes, earth rods or pins. This may be achieved as a consequence of main bonding or by installing additional earth rods and/or tapes.'⁵⁴

NOTE: The Customer's electrical installation designers/installers can be referred to BS 7671 Regulation 717.411.4 and IET Guidance Note 7. BS7909 provides guidance in relation to outside broadcast facilities.

6.4.3 Bonding Requirements

It is essential that with any premises using a PME Earth Terminal that an *Equipotential Zone* is created so that, in the event of a broken neutral on the supply system, all relevant conductive-parts are at the same potential. BS 7671 specifies that main equipotential bonding shall be installed as part of the customer installation.

Water, gas and any other metallic services, excluding telephonic services but including any metallic sheath of telecommunication cable, on the customer's premises must be connected to the PME Earth Terminal via the customer's *Main Earthing Terminal*. Any other *Extraneous-conductive-parts*, such as exposed steelwork with a steel-framed building, which are or might be expected to come into electrical contact with the earth and are within reach (e.g. 2.5m horizontally) of any *Exposed-conductive-parts* of the customer's electrical installation must also be connected to the PME Earth Terminal via the customer's Main Earthing Terminal. The bonding connection to any water, gas or other service must be made as near as practicable to the point of entry of that service into the premises.

With PME the minimum copper-equivalent cross-sectional area (CSA) requirements for main equipotential bonding conductors are based on the supply neutral conductor size to account for the possibility of a broken neutral. From BS 7671 Table 54.8 we obtain Figure 23 and Table 3 detailing the minimum size of main equipotential bonding, U, according to supply neutral conductor size, S_N . This does not apply to highway power supplies and *Street Furniture* – see BS 7671 Regulation 544.1 – where the minimum of 6mm² applies.

⁵⁴ IEE Guidance Note 7.

Table 3 – Size of Main Equipotential Bonding Copper Conductors

Supply Neutral Conductor Copper-equivalent CSA, S_N (mm ²)	Corresponding WPD Service/Mains LV Cables	Minimum Copper Bonding Conductor CSA (Or Continuously Rated Equivalent), U (mm ²)
$S_N \leq 35 \text{ mm}^2$	16mm ² , 25mm ² & 35mm ² CNE	10 mm ²
$35\text{mm}^2 < S_N \leq 50 \text{ mm}^2$	70mm ² 3-core CNE	16 mm ²
$50\text{mm}^2 < S_N \leq 95 \text{ mm}^2$	95mm ² 3-core CNE	25 mm ²
$95\text{mm}^2 < S_N \leq 150 \text{ mm}^2$	185mm ² & 300 mm ² 3-core CNE	35 mm ²
$S_N > 150 \text{ mm}^2$	95mm ² , 185mm ² & 300 mm ² 4-core SNE	50 mm ²

Figure 23 – TN-C-S (PME) Bonding Requirements

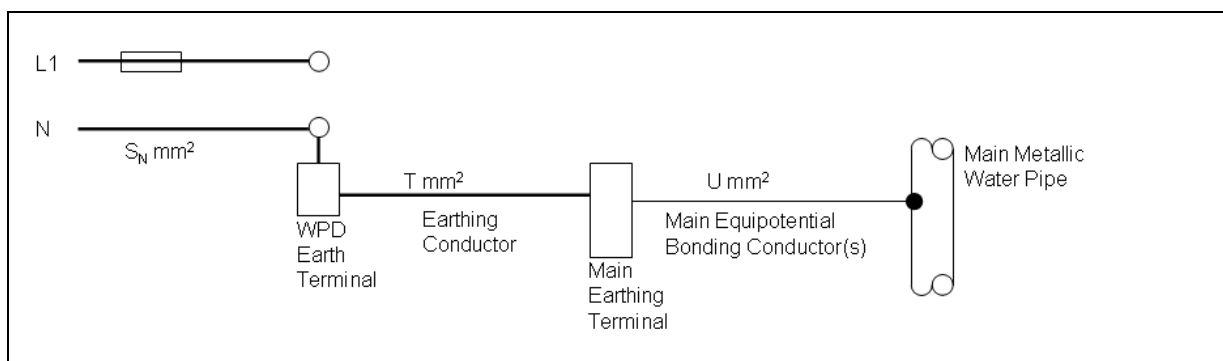

NOTE: S_N = supply neutral conductor CSA, T = earthing conductor CSA and U = main equipotential bonding conductor CSA.

The customer's *earthing conductor* connection between the PME Earth Terminal and the customer's Main Earthing Terminal must be no smaller than the main equipotential bonding conductors. In addition, it must also meet the requirements defined in relation to phase conductor size, S , detailed in Section 6.5.2.

Occasionally a service is provided to a position remote from the building it supplies. The size of the bonding in the remote building, U , and protective conductor connecting between Main Earthing Terminal and remote Earth Terminal, T , is related to the size of the WPD incoming service. See Figure 24

Figure 24 – Bonding Requirement - Service Terminating In A Separate Building

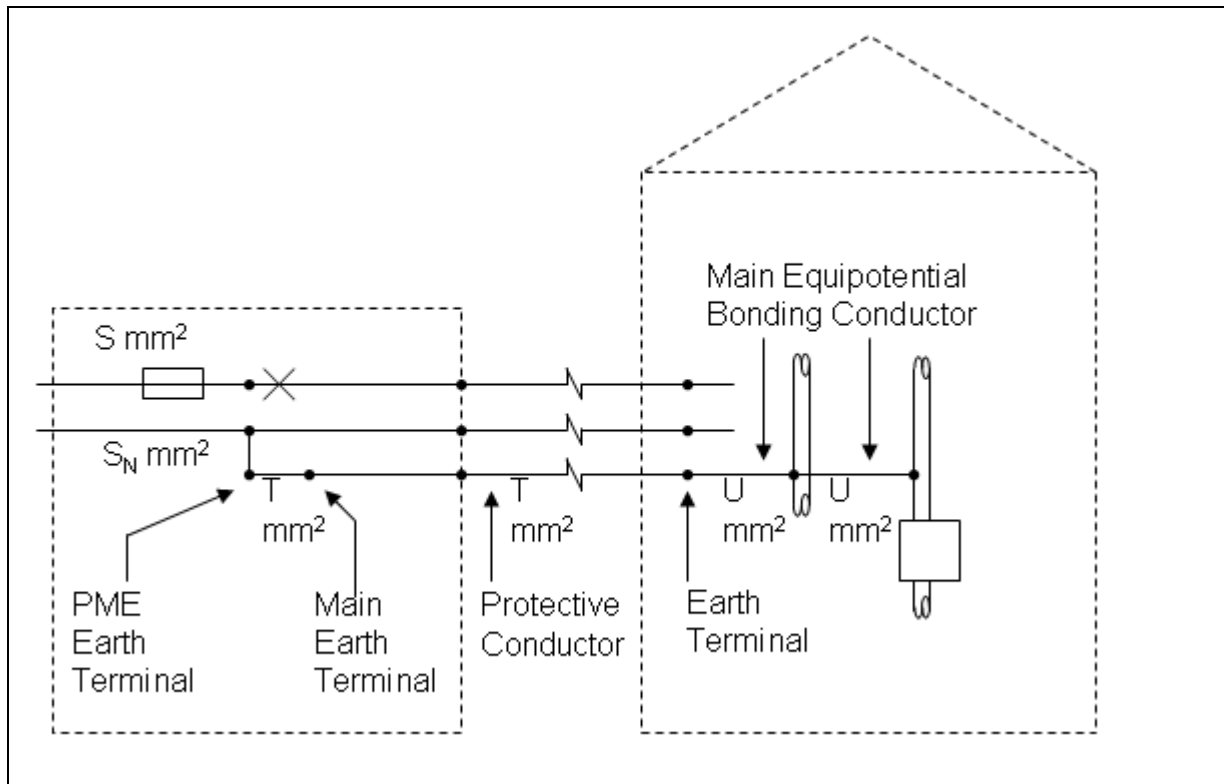

NOTE: S = supply phase conductor CSA, S_N = supply neutral conductor CSA, T = earthing conductor CSA and protective conductor CSA and U = main equipotential bonding conductor CSA.

6.5 TN-S (SNE) Earthing

6.5.1 Applications

TN-S or SNE earthing has applications where the existing network is not PME or where the network is PME but the voltage occurring if a broken CNE neutral were to happen would be held sufficiently low by the presence of an earth electrode with earth resistance not exceeding 20Ω . To avoid limiting future conversion of a SNE network to PME, a SNE Earth Terminal must not be offered in cases where a PME Earth Terminal is prohibited.

6.5.2 Bonding Requirements

Unlike with PME (TN-C-S), the minimum CSA of earthing and bonding conductors for TN-S earthing is based on the phase conductor size. From BS 7671 Table 54.7 we obtain:

- $T = S$ for $S \leq 16\text{mm}^2$
- $T = 16\text{mm}^2$ for $16\text{mm}^2 < S \leq 35\text{mm}^2$
- $T = S/2$ for $S > 35\text{mm}^2$
- $U \geq T/2$; $U_{\text{minimum}} = 6\text{mm}^2$

Where S = phase conductor CSA, T = earthing conductor CSA and U = main equipotential bonding conductor CSA.

See Figure 25 and Table 4

Figure 25 – TN-S (SNE) Bonding Requirements

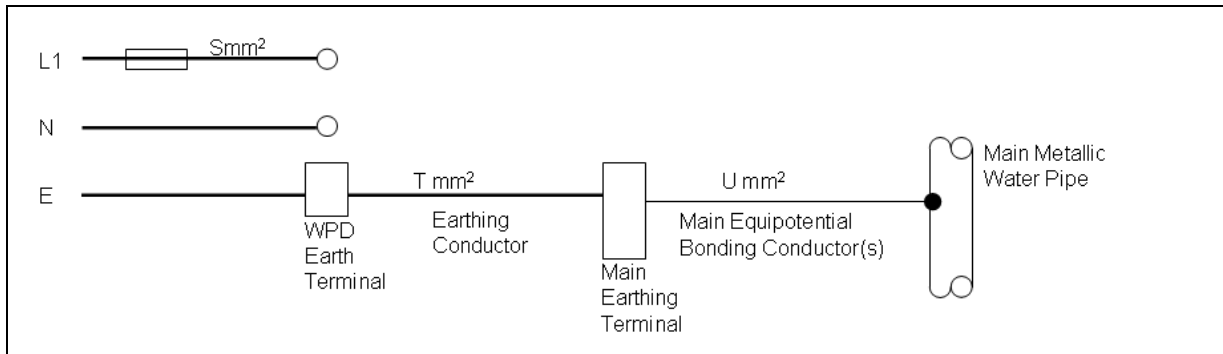

NOTE: S = supply phase conductor CSA, T = earthing conductor CSA and U = main equipotential bonding conductor CSA.

Table 4 – Earthing and Bonding Conductor Sizes for TN-S Earthing System

Phase Conductor Copper Equivalent CSA, S (mm ²)	Minimum Copper Earthing Conductor CSA, T (mm ²)	Minimum Copper Main Equipotential Bonding Conductor CSA, U (mm ²)
10	10	6
16	16	10
25	16	10
35	16	10
50	25	16

6.6 TT Earthing

With this type of earthing the customer uses their own independent earth electrode. See Figure 12 and Figure 18. Note that for an earth fault the current must pass through both the customer's earth electrode and the WPD transformer neutral earth electrode, in parallel with any other neutral earths; consequently, the earth loop impedance can be high, as the customer typically has a single earth rod earth electrode, and the earth fault current low.

6.6.1 Applications

TT earthing has applications where it is unsafe to offer or use a WPD Earth Terminal. PME may be used for one part of the installation (e.g. permanent buildings) but not another (e.g. Quarry workings) because of the risk.

Direct earthing, where the independent earth used is the water supply pipe, is a form of TT earthing. This has not been permitted since 1966 but as this is not retrospective there are existing installations in use. Replacement of metal water pipes with plastic requires customers to revise their earthing and possibly protection too.

6.6.2 Residual Current Devices

Under BS 7671 Regulations Residual Current Device (RCD) protection is preferred with TT earthing. Further, where an overcurrent protective device is to be used for earth fault protection the protective device operating current for disconnection in 0.2s must be less than or equal to $230V/Z_s$ where Z_s = earth fault loop impedance to the point of fault. Overcurrent protection cannot normally meet this requirement and hence the RCD use.

Note that RCD protection may also be found in TN installations (i.e. TN-S or TN-C-S). Note also that older installations may have voltage-operated earth leakage circuit breakers (ELCB) rather than RCDs. The former have two separate earth terminals – one for an earthing connection (i.e. circuit protective conductor) to the load and one to the Means of Earthing. ELCBs are now not recognized in BS 7671.

6.6.3 Bonding Requirements

The fast fault disconnection obtained by use of an RCD allows small sizes of earthing conductors. Regulation 544.1.1 limits the CSA of main equipotential bonding conductor to a minimum of 6 mm² copper-equivalent.

6.7 Extracts From ESQC Regulations & DTI Guidance

Clause	Regulation	DTI Guidance
7(1)	A generator or distributor shall, in the design, construction, maintenance or operation of his network, take all reasonable precautions to ensure continuity of the supply neutral conductor.	Duty holders will be aware of the importance of maintaining continuity of the supply neutral conductor to avoid potentially dangerous situations on consumers' premises. This requirement is particularly relevant to supplies offered from protective multiple earthing (PME) systems where the functions of the supply neutral and protective conductors are often combined in the same conductor. Disconnection of the combined supply neutral and protective conductor could cause danger on a consumer's premises if there is no equipotential bonding (see regulation 9 <i>Protective Multiple Earthing</i>).

Clause	Regulation	DTI Guidance
8(4)	A consumer shall not combine the neutral and protective functions in a single conductor in his consumer's installation.	Consumers may not combine the functions of neutral and protective conductors in their installations, i.e. consumers must not operate TN-C systems or use CNE cables within their installations. Distributors operating such systems must comply with additional requirements (see regulation 9 <i>Protective multiple earthing</i>).
9(1)	This regulation applies to distributors' low voltage networks in which the neutral and protective functions are combined.	This regulation is targeted at low voltage networks arranged for protective multiple earthing (PME), i.e. where the neutral and protective functions have been combined in a single conductor, including networks employing separate neutral and protective conductors which have been converted for PME operation.

Clause	Regulation	DTI Guidance
9(4)	The distributor shall not connect his combined neutral and protective conductor to any metalwork in a caravan or boat.	<p>Distributors must not offer connections to earthing terminals from PME networks for consumers' installations in caravans or boats. The particular risk at these installations arises from the possibility of the supply neutral conductor becoming disconnected from earth, possibly causing the metalwork in the caravan or boat to rise to live potential (assuming that the caravan or boat does not benefit from an independent connection with earth). Persons entering or exiting the caravan or boat would then be at risk of electric shock.</p> <p>There is a small inherent risk of danger to consumers (resulting from the possible disconnection of the supply neutral conductor under fault conditions) with all PME networks (see comments for regulation 7(1)), however it is DTI's view that the risks are acceptable provided that:</p> <ul style="list-style-type: none"> (i) distributors comply with the requirements for multiple earthing (regulation 9(2)) and take precautions to ensure continuity of the supply neutral conductor (regulation 7(1)); and, (ii) consumers comply with the equipotential bonding requirements of <i>BS 7671 Requirements for Electrical Installations</i>. Distributors should note that at the time of connection they should be satisfied that consumers' installations comply with <i>BS 7671</i> (see regulation 25 <i>Connections to installations or to other networks</i>). <p>Special consideration should be given to the earthing and protection arrangements for certain installations where reliance on the connection of the consumer's protective conductor with the distributor's combined neutral and protective conductor could result in more significant risks.</p> <p>For example, installations where it may prove difficult to attach and maintain all the necessary equipotential bonding connections (e.g. farms or building sites), installations at certain wet environments (e.g. swimming pools and petrol filling stations) and certain installations outside the equipotential zone of buildings (e.g. certain types of street furniture). Further advice may be sought from the Health and Safety Executive or the Institution of Electrical Engineers.</p>

Clause	Regulation	DTI Guidance
24(4)	Unless he can reasonably conclude that it is inappropriate for reasons of safety, a distributor shall, when providing a new connection at low voltage, make available his supply neutral conductor or, if appropriate, the protective conductor of his network for connection to the protective conductor of the consumer's installation.	For a new connection the distributor would normally be expected to offer to connect his combined neutral and protective conductor (or protective conductor) to the consumer's earth terminal. In certain circumstances the distributor may take the view that such connection to the consumer's protective conductor could result in danger, and therefore not connect his combined neutral and protective conductor to the consumer's protective conductor via the earthing terminal.
24(5)	In this regulation the expression "new connection" means the first electric line, or the replacement of an existing electric line, to one or more consumer's installations.	Examples of situations where caution would be warranted are included in comments for regulation 9 <i>Protective Multiple Earthing</i> . Where the distributor does not offer to connect his protective conductor to the consumer's earthing terminal he should advise the consumer in writing of the reasons for not offering such a connection. In these circumstances the consumer should install his own earthing arrangements and protective devices in accordance with the requirements of <i>BS 7671 Requirements for Electrical Installations</i> .

Clause	Regulation	DTI Guidance
25(1) & (2)	<p>(1) No person shall make or alter a connection from a distributor's network to a consumer's installation, a street electrical fixture or to another distributor's network without that distributor's consent, unless such consent has been unreasonably withheld.</p> <p>(2) A distributor shall not give his consent to the making or altering of the connection referred to in paragraph (1), where he has reasonable grounds for believing that -</p> <p>(a) the consumer's installation, street electrical fixture or other distributor's network fails to comply with British Standard Requirements or these Regulations; or</p> <p>(b) the connection itself will not be so constructed, installed, protected and used or arranged for use, so as to prevent as far as is reasonably practicable, danger or interruption of supply.</p>	<p>Regulation 25 is targeted at persons physically connecting a supply on site, and hence there is no reference to the role of supplier. Duty holders should note that these requirements are for safety and supply continuity purposes only, and they do not usurp in any way the commercial arrangements for provision of new connections involving distributors, suppliers, meter operators, developers and consumers. This regulation should be seen as an additional requirement involving duty holders installing equipment used to provide a connection to consumers' installations, street furniture or other networks.</p> <p>Regulation 25(1) requires that persons installing or altering connections to consumers' installations, street furniture or other networks must have consent from the local distributor in order to do so.</p> <p>There are two circumstances in which the distributor must withhold his consent insofar as the requirements of these Regulations are concerned; those are where he has reason to believe that:</p> <p>(i) There is or may be a technical or safety problem with the installation or new network to be connected to the local distributor's network. The consumer or other distributor may have to satisfy the local distributor that the equipment or new network is safe and technically sound by providing evidence that the equipment or new network complies with <i>BS 7671 Requirements for Electrical Installations</i> (for consumers' installations) or complies with these Regulations (for new networks). Consent for the connection of a new network may take the form of an agreement between the distributor and developer covering important areas such as design, planning, materials, installation and records.</p> <p>Cont.</p>

Clause	Regulation	DTI Guidance
25(1) & (2)		<p>(ii) There is or may be a technical or safety problem with the point of connection, i.e. the cable joint or other electrical equipment used to connect the local distributor's network to the installation, street electrical fixture or other network. The local distributor may require evidence that the person making this joint or fitting appropriate electrical equipment is technically competent, can do the work safely and will comply with the local distributor's safety and technical requirements. Such evidence may include reference to an approved registration scheme for craftsmen, e.g. the Lloyds Register. (Where a distributor engages his own staff or contractors to install such connections those persons are already deemed to have consent for the connection work.)</p> <p>If the distributor withholds his consent for the connection for any other reason, then he will have to be acting reasonably in so doing (paragraph 25(2)).</p> <p>Duty holders or persons not complying with the requirements of regulation 25 may be subject to prosecution – see regulation 35 <i>Offences</i>.</p>

6.8 **Determination Of Minimum Earth Resistance To Prevent Customer Earthing And Bonding Conductor Exceeding Rating For Open Circuit Neutral**

Table 5 provides calculated minimum earth resistance for a Lightning Protection System Earth Termination to avoid BS 7671 compliant customer earthing and bonding exceeding its rating. Based on these values a 5Ω limit is set.

Table 5 – Minimum Lightning Protection System Earth Termination Earth Resistance by Supply/bonding Size and Load Unbalance

Loading Case	Supply neutral copper-equivalent CSA (mm ²)	Minimum main equipotential bonding conductor copper-equivalent CSA (mm ²)	Rating (A)	Minimum Lightning Protection System Earth Resistance ≤ (Ω)
Severely unbalanced 3-ph (400A/100A/200A)	$S_N \leq 35 \text{ mm}^2$	10	46	4.13
	$35\text{mm}^2 < S_N \leq 50 \text{ mm}^2$	16	61	2.90
	$50\text{mm}^2 < S_N \leq 95 \text{ mm}^2$	25	80	2.01
	$95\text{mm}^2 < S_N \leq 150 \text{ mm}^2$	35	99	1.46
	$S_N > 150 \text{ mm}^2$	50	119	1.07
Moderately unbalanced 3-ph (250A/200A/250A)	$S_N \leq 35 \text{ mm}^2$	10	46	1.52
	$35\text{mm}^2 < S_N \leq 50 \text{ mm}^2$	16	61	0.29
	$50\text{mm}^2 < S_N \leq 95 \text{ mm}^2$	25	80	N/A
	$95\text{mm}^2 < S_N \leq 150 \text{ mm}^2$	35	99	N/A
	$S_N > 150 \text{ mm}^2$	50	119	N/A
Unbalanced 2-ph (200A/100A)	$S_N \leq 35 \text{ mm}^2$	10	46	3.67
	$35\text{mm}^2 < S_N \leq 50 \text{ mm}^2$	16	61	2.44
	$50\text{mm}^2 < S_N \leq 95 \text{ mm}^2$	25	80	2.88
	$95\text{mm}^2 < S_N \leq 150 \text{ mm}^2$	35	99	1.00
	$S_N > 150 \text{ mm}^2$	50	119	0.60

Loading Case	Supply neutral copper-equivalent CSA (mm ²)	Minimum main equipotential bonding conductor copper-equivalent CSA (mm ²)	Rating (A)	Minimum Lightning Protection System Earth Resistance ≤ (Ω)
1-ph (100A)	$S_N \leq 35 \text{ mm}^2$	10	46	2.7
	$35\text{mm}^2 < S_N \leq 50 \text{ mm}^2$	16	61	1.47
	$50\text{mm}^2 < S_N \leq 95 \text{ mm}^2$	25	80	0.58
	$95\text{mm}^2 < S_N \leq 150 \text{ mm}^2$	35	99	0.02
	$S_N > 150 \text{ mm}^2$	50	119	N/A

SUPERSEDED DOCUMENTATION

This document supersedes ST:TP21E/2 dated July 2019 which has now been withdrawn.

RECORD OF COMMENT DURING CONSULTATION

No comments received

ANCILLARY DOCUMENTATION

ESQC Regulations 2002	The Electricity Safety, Quality and Continuity Regulations 2002
BS 5588 Part 5	Fire Precautions in the Design, Construction and Use of Buildings – Part 5: Access and Facilities for Fire Fighting
BS 7375	Distribution of Electricity on Construction and Demolition Sites – Code of Practice
BS 7671	Requirements for Electrical Installations
BS 7909	Code of Practice for temporary electrical systems for entertainment and related purposes
DTI Guidance	Guidance on The Electricity Safety, Quality and Continuity Regulations 2002
ENA Engineering Recommendation G12/4-1	Requirements for the Application of Protective Multiple Earthing to Low Voltage Networks
ENA Engineering Recommendation P24	AC Traction Supplies to British Rail
ENA Engineering Technical Report 123	Guideline for Managing the Interfaces between Utility services and Light Rapid Transit Systems
ST:CAØU/1	Procedures for Making LV Service Cable Cut-Out Terminations
POL:NC4/1	Relating to the giving of consent to other parties to make or alter a connection between a consumer's installation and the WPD Low Voltage Distribution System
POL:NC5/1	The Required Inspections and Tests of an LV Service prior to Connection
ST:NC5A/1	The Required Inspections and Tests of an LV Service prior to Connection

KEY WORDS

Bonding, Customer Earthing, Earth Electrode, Earthing, Earthing Conductor, Earth terminal, Equipotential, PME, PNB, RCD, SNE, TN-C-S, TN-S, TT.